

**Material:**

Fork head and bolts of free-cutting steel, spring leg of spring steel

**Version:**

Galvanized and chromated

**On request:**

SPECIAL MEASURES - M18, M20, M24, M30, M36, M42 and M48.

For left-hand thread add "LH" (ex. PA7320-05-10-M5-LH)

For Stainless Steel add "SST" (ex. PA7320-05-10-M5-SST)

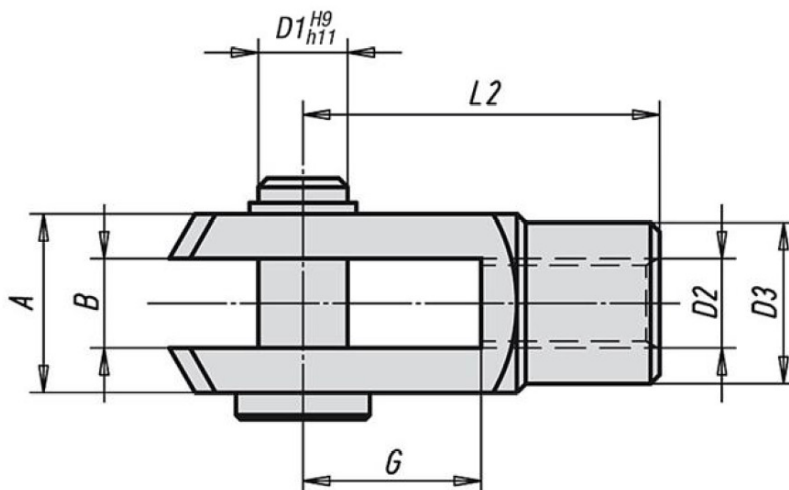

**Overview of items**

Order No.	B	G	D1	D2	D3	L2	A	Approx. weight kg
PA7320-05-10-M5	5	10	5	M5	9	20	10	0,011
PA7320-06-12-M6	6	12	6	M6	10	24	12	0,018
PA7320-08-16-M8	8	16	8	M8	14	32	16	0,046
PA7320-08-32-M8	8	32	8	M8	14	48	16	0,062
PA7320-10-20-M10	10	20	10	M10	18	40	20	0,091
PA7320-10-20-M10x1,25	10	20	10	M10x1,25	18	40	20	0,091
PA7320-10-40-M10	10	40	10	M10	18	60	20	0,120
PA7320-12-24-M12	12	24	12	M12	20	48	24	0,150
PA7320-12-24-M12x1,25	12	24	12	M12x1,25	20	48	24	0,150
PA7320-12-48-M12	12	48	12	M12	20	72	24	0,201
PA7320-12-48-M12x1,25	12	48	12	M12x1,25	20	72	24	0,201
PA7320-14-28-M14	14	28	14	M14	24	56	27	0,218
PA7320-16-32-M16	16	32	16	M16	26	64	32	0,338
PA7320-16-32-M16x1,50	16	32	16	M16x1,50	26	64	32	0,338