

**Material:**

Fork head and bolts of free-cutting steel, spring leg of spring steel

**Version:**

Galvanized and chromated

**On request:**

SPECIAL MEASURES - M18, M20, M24, M30, M36, M42 and M48.

For left-hand thread add "LH" (ex. PA7310-05-10-M5-LH)

For Stainless Steel add "SST" (ex.PA7310-05-10-M5-SST)

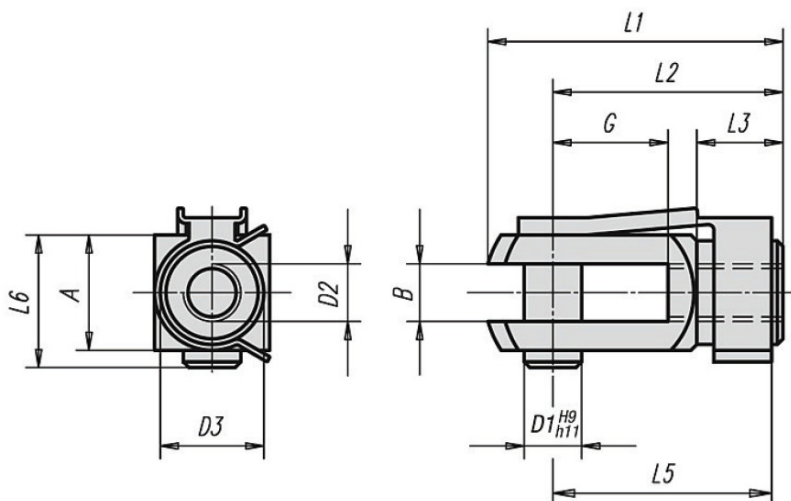

**Overview of items**

Fork joints with snap-on spring

Order No.	Surface finish	B	G	D1	D2	D3	L1	L2	L3	~L5	~L6	A	Approx. weight g
PA7310-05-10-M5	right-handed thread	5	10	5	M5	9	26	20	7,5	19	12	10	12,0
PA7310-06-12-M6	right-handed thread	6	12	6	M6	10	31	24	9	23	14	12	20,0
PA7310-08-16-M8	right-handed thread	8	16	8	M8	14	42	32	12	31	19	16	37,0
PA7310-08-32-M8	right-handed thread	8	32	8	M8	14	58	48	12	47	19	16	66,0
PA7310-10-20-M10	right-handed thread	10	20	10	M10	18	52	40	15	39	23	20	93,0
PA7310-10-20-M10x1,25	right-handed thread	10	20	10	M10x1,25	18	52	40	15	39	23	20	93,0
PA7310-10-40-M10	right-handed thread	10	40	10	M10	18	72	60	15	59	23	20	137,0
PA7310-10-40-M10x1,25	right-handed thread	10	40	10	M10x1,25	18	72	60	15	59	23	20	137,0
PA7310-12-24-M12	right-handed thread	12	24	12	M12	20	62	48	18	47	28	24	155,0
PA7310-12-24-M12x1,25	right-handed thread	12	24	12	M12x1,25	20	62	48	18	47	28	24	155,0
PA7310-12-48-M12	right-handed thread	12	48	12	M12	20	86	72	18	69	28	24	210,0
PA7310-12-48-M12x1,25	right-handed thread	12	48	12	M12x1,25	20	86	72	18	69	28	24	210,0
PA7310-14-28-M14	right-handed thread	14	28	14	M14	24	72	56	22,5	52	31	27	223,0
PA7310-16-32-M16	right-handed thread	16	32	16	M16	26	83	64	24	62	36	32	352,0
PA7310-16-32-M16x1,50	right-handed thread	16	32	16	M16x1,50	26	83	64	24	62	36	32	352,0