

Magnets



Technical data for pot magnets

Structure:

Pot magnets are magnets that, due to their structure have only one attracting surface. No other surface is magnetic. This construction makes it possible to limit the three-dimensional affect of the magnetic field so that no unintentional magnetization of the entire workpiece in contact with the pot magnet, or of the machine elements surrounding the magnet occurs.

Designs:

The deep pot magnets series:

K0545

K0546

K0547

have a core made of the permanent magnetic material AlNiCo, which is inserted for magnetic shielding into a soft iron pot with an intervening sleeve made of a non-magnetic material.

The shallow pot magnets series:

K0548

K0549

have a core made of the permanent magnetic ceramic material SrFe (hard ferrite) . This is also inserted into soft iron pot to create the desired magnetic shielding.

The pot magnets series:

K0550

K0551

have a SmCo core, an alloy of rare metallic elements together with cobalt.

SmCo increases the magnetic force by three to five times that of AlNiCo or hard ferrite magnets by the same magnet size.

Magnetic strengths:

The values indicated in the table are minimum values that are achieved for a vertical pull-down with full-surface contact of the pot magnets on soft iron or low-carbon steel workpieces of sufficient thickness. By unclean pole faces or uneven workpieces, air gaps are formed which sharply decrease the attractive force. It is therefore advisable to always ensure a clean pole face and to clean it from time to time if necessary.

Diagram:

Reduction of the magnetic strength of a deep pot magnet with increasing air gap (non-magnetic intermediate layers have the same effect as air gaps).

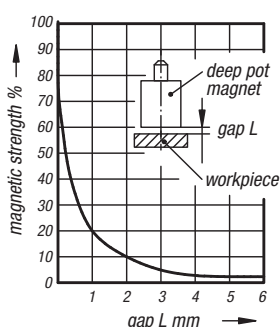

Mounting instructions for shielded pot magnets without pins

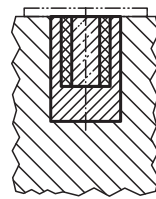

not correct

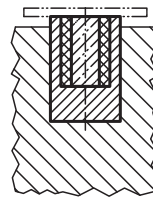

correct

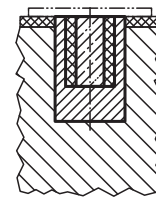

correct

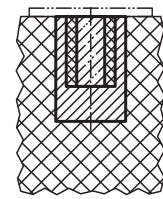

correct

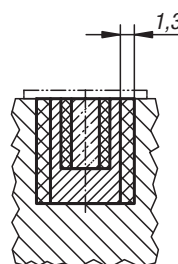

not correct

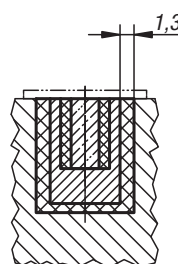

correct

SmCo pot magnets (deep or shallow) must not be mounted directly in iron, but must be screwed, glued, pressed or cast into a sleeve of non-magnetic material (see illustration below).

Magnet series shielded system

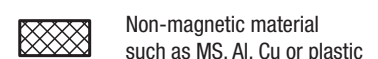
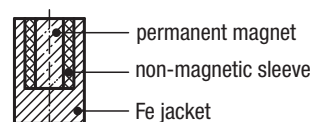

Installation or fastening possibilities of pot magnets

Order No.	Description	System	Temperature* max. °C	Fastening possibility
from K0545.01 to K0545.10	deep pot	shielded	450	Press in/shrink-fit/ glue in
from K0546.01 to K0546.10	deep pot	shielded	450	Solder in (soft solder)/ glue in
from K0547.01 to K0547.10	deep pot	shielded	450	Rivet pin/ screw in
from K0551.01 to K0551.15	deep pot	shielded	200	Press in/glue in screw in
from K0548.01 to K0548.10	shallow pot	shielded	100	Press in/glue in
from K0549.01 to K0549.26	shallow pot	shielded	100	Screw in
from K0550.01 to K0550.18	shallow pot	shielded	200	Press in/glue in

*Long-term heating or alternating thermal stresses may lead to mechanical changes in the magnet system. In many cases they have no influence on the function. The same applies for chemical stresses (chemical baths, aggressive gases, etc).

Magnets deep pot

AlNiCo with fitting tolerance



Material:

Housing, steel.

Magnetic core AlNiCo.

Version:

Housing bright.

Sample order:

K0545.01

Note:

Shielded system. Diameter „D“ ground to a h6 tolerance. Fastening possibilities by pressing, shrink-fit or gluing.

Deep pot magnets can be shortened by the dimension „H“ with no loss of attracting force.

Temperature range:

max. 450°C.

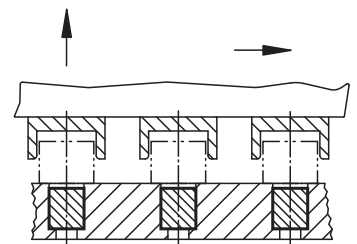
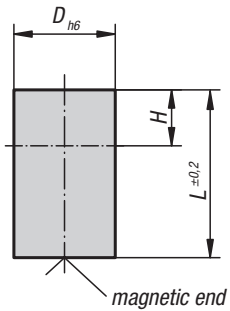

KIPP Magnets deep pot AlNiCo with fitting tolerance

Order No.	D	L	H	Magnetic force N
K0545.01	6	10	2	1,5
K0545.02	8	12	3	3,5
K0545.03	10	16	6	7
K0545.04	13	18	7	10
K0545.05	16	20	5	18
K0545.06	20	25	6	42
K0545.07	25	30	5	96
K0545.08	32	35	3	180
K0545.09	40	45	5	240
K0545.10	50	50	2	420



Magnets deep pot

AlNiCo without fitting tolerance



Material:

Housing, steel.
Magnetic core AlNiCo.

Version:

Housing, galvanized.

Sample order:

K0546.01

Note:

Shielded system. Diameter „D“ without fitting tolerance. Fastening possibilities are pressing, shrink-fit or gluing.
Deep pot magnets can be shortened by the dimension „H“ with no loss of attracting force.

Temperature range:

max. 450°C.

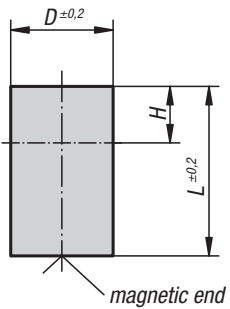

KIPP Magnets deep pot AlNiCo without fitting tolerance

Order No.	D	L	H	Magnetic force N
K0546.01	6	20	12	1,5
K0546.02	8	20	11	3,5
K0546.03	10	20	10	7
K0546.04	13	20	9	10
K0546.05	16	20	5	18
K0546.06	20	25	6	42
K0546.07	25	35	10	96
K0546.08	32	40	8	180
K0546.09	40	50	10	240

Magnets deep pot with pin

AlNiCo

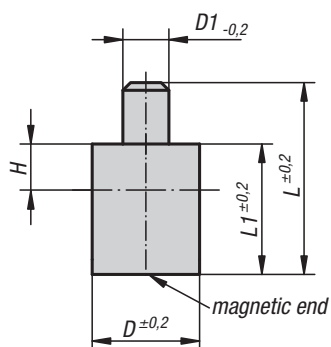
**Material:**

Housing, steel.
Magnetic core AlNiCo.

Version:

Housing, galvanized.

Sample order:

K0547.01

Note:

Deep pot magnets with smooth pin, shielded system.
The magnets can be shortened by the dimension „H“
(to lengthen the pin) with no loss of attracting force.

Temperature range:

max. 450°C.

KIPP Magnets deep pot with pin AlNiCo

Order No.	D	D1	L	L1	H	Magnetic force N
K0547.01	6	3	28	20	2	1,7
K0547.02	8	3	28	20	3	4
K0547.03	10	4	28	20	6	8,5
K0547.04	13	4	28	20	7	12
K0547.05	16	5	28	20	5	20
K0547.06	20	6	33	25	6	50
K0547.07	25	8	45	35	5	115
K0547.08	32	10	50	40	3	200
K0547.09	40	15	70	50	5	240
K0547.10	50	18	85	60	2	420



Magnets shallow pot

hard ferrite



Material:

Housing, steel.

Magnetic core hard ferrite.

Version:

Housing, galvanized.

Sample order:

K0548.01

Note:

Shallow pot magnets without threaded bush. These magnets are pressed or glued into the receiving holes.

Hairline cracks in the magnetic material are unavoidable for technical reasons in the D=80 version. They do not impair the attracting function of the magnets in any way.

Temperature range:

max. 200°C.

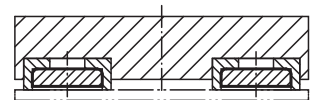
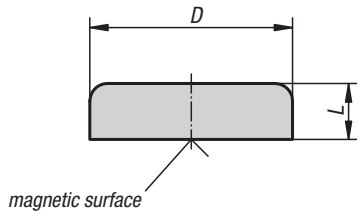

KIPP Magnets shallow pot hard ferrite

Order No.	D	L	Magnetic force N
K0548.01	10 ±0,15	4,5	4
K0548.02	13 ±0,15	4,5	10
K0548.03	16 ±0,15	4,5	18
K0548.04	20 ±0,15	6	30
K0548.05	25 ±0,15	7	40
K0548.06	32 ±0,20	7	80
K0548.07	40 ±0,20	8	125
K0548.08	50 ±0,20	10	220
K0548.09	63 ±0,20	14	350
K0548.10	80 ±0,25	18	600

Magnets shallow pot with thread

hard ferrite



Form A

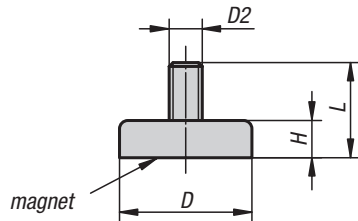

Form B

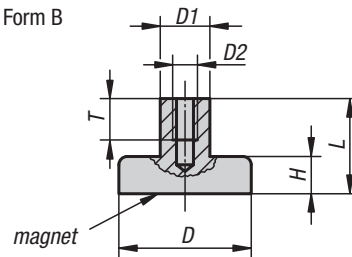

Material:

Housing, steel.

Magnetic core hard ferrite.

Version:

Housing, galvanized.

Sample order:

K0549.01

Note:

Shallow pot magnets, shielded system.

Hairline cracks in the magnetic material are unavoidable for technical reasons in D=80, D=100 and D=125 versions. They do not impair the attracting function of the magnets in any way.

Temperature range:

max. 200°C.

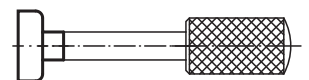

KIPP Magnets shallow pot with thread, hard ferrite

Order No. Form A	Order No. Form B	D	D1	D2	L	H	T	Magnetic force N
K0549.21	K0549.01	10 ±0,15	-/6	M3	11,5	4,5	-/5	4
K0549.22	K0549.02	13 ±0,15	-/6	M3	11,5	4,5	-/5	10
K0549.23	K0549.03	16 ±0,15	-/6	M3	11,5	4,5	-/5	18
K0549.24	K0549.04	20 ±0,15	-/6	M3	13	6	-/5	30
K0549.25	K0549.05	25 ±0,15	-/8	M4	15	7	-/6	40
K0549.26	K0549.06	32 ±0,20	-/8	M4	15	7	-/6	80
-	K0549.07	40 ±0,20	10	M5	18	8	8	125
-	K0549.08	50 ±0,20	12	M6	22	10	10	220
-	K0549.09	63 ±0,20	15	M8	30	14	14	350
-	K0549.10	80 ±0,25	20	M10	34	18	14	600
-	K0549.11	99 ±0,25	22	M12	42	22	17	900
-	K0549.12	125 ±0,25	25	M14	50	26	20	1.300



Magnets shallow pot

SmCo



Form A

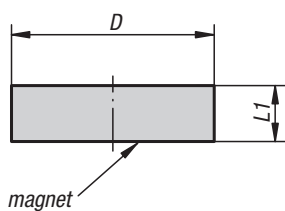

Form B

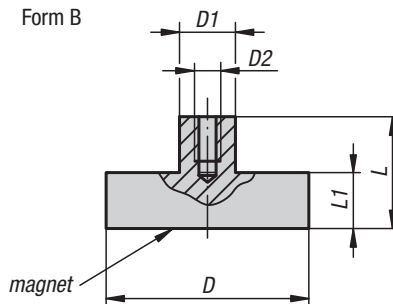
**Material:**

Housing, steel.
Magnetic core, SmCo.

Version:

Housing, galvanized.

Sample order:

K0550.01

Note:

Shallow pot magnets, shielded system. Magnets with an SmCo core have three to five times the attracting force of AlNiCo or hard ferrite magnets.

Temperature range:

max. 200°C.

KIPP Magnets shallow pot SmCo

Order No. Form A	Order No. Form B	D	D1	D2	L	L1	Magnetic force N
K0550.01	K0550.11	6 ±0,15	-6	-M3	-11,5	4,5	5
K0550.02	K0550.12	8 ±0,15	-6	-M3	-11,5	4,5	11
K0550.03	K0550.13	10 ±0,15	-6	-M3	-11,5	4,5	20
K0550.04	K0550.14	13 ±0,15	-6	-M3	-11,5	4,5	40
K0550.05	K0550.15	16 ±0,15	-6	-M4	-11,5	4,5	60
K0550.06	K0550.16	20 ±0,15	-8	-M4	-13	6	90
K0550.07	K0550.17	25 ±0,15	-8	-M4	-14	7	150
K0550.08	K0550.18	32 ±0,20	-10	-M5	-15,5	7	220

Magnets deep pot

SmCo

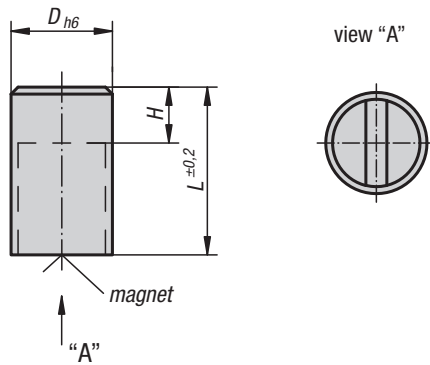
**Material:**

Housing brass.

Magnetic core SmCo.

Sample order:

K0551.01

Note:

Smooth design, shielded system. Diameter „D“ ground with h6 tolerance. Under no circumstances may SmCo magnets be pressed directly into iron, as otherwise loss of attractive force due to magnetic short circuits occurs. SmCo magnets are especially suitable for direct use in spot-welding machines, as no demagnetisation occurs.

Deep pot magnets can be shortened by the dimension „H“ with no loss of attractive force.

Temperature range:

max. 200°C.

KIPP Magnets deep pot SmCo

Order No.	D	L	H	Magnetic force N	Distance to iron wall/mm
K0551.01	6	20	10	8	1,5
K0551.03	8	20	10	22	1,5
K0551.05	10	20	8	40	2
K0551.07	13	20	6	60	2,5
K0551.09	16	20	2	125	3
K0551.11	20	25	5	250	4
K0551.13	25	35	7	400	5
K0551.15	32	40	4,5	600	6



Magnets deep pot with internal thread

NdFeB

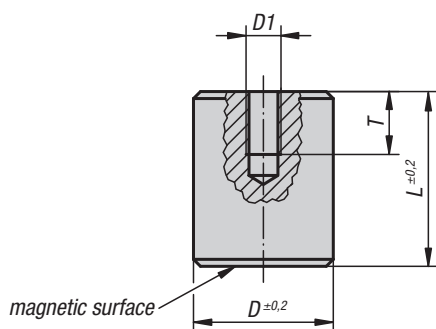

Material:
Housing, steel.
Magnetic core NdFeB.

Version:
Housing, galvanized.

Sample order:
K0552.01

Note:
Shielded system. Deep pot magnets are used for mounting in steel and iron. This requirement is principally stipulated in plant and machine construction.
Can also be used in blind holes.

Size D=50 has 4 magnets Ø18 mm.

Temperature range:
max. 80°C.

KIPP Magnets deep pot with internal thread NdFeB

Order No.	D	D1	L	T	Can be shortened by (mm)	Magnetic force N
K0552.01	8	M3	12	5	3	12
K0552.02	10	M4	16	7	7	24
K0552.03	13	M4	18	7	3	60
K0552.04	16	M4	20	7	6	90
K0552.05	20	M5	25	9	9	135
K0552.06	25	M6	30	9	10	190
K0552.07	35	M8	40	13	10	300
K0552.08	50	M12	50	13	13	550

Magnets shallow pot

NdFeB



Form A

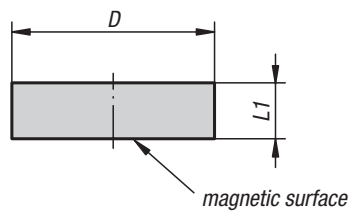

Form B

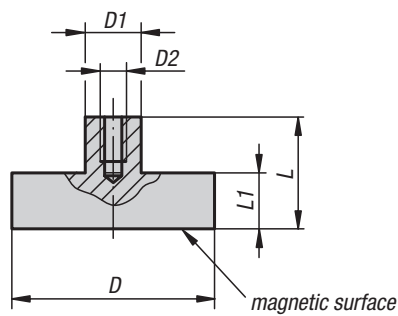

Form C

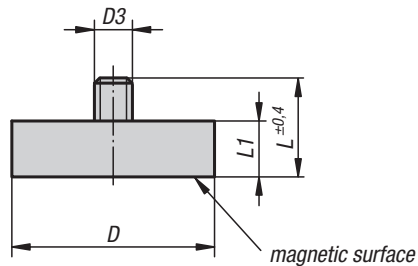
**Material:**

Housing, steel.
Magnetic core NdFeB.

Version:

Housing, galvanized.

Sample order:

K0553.01

Note:

Shielded system. With the permanent magnetic material NdFeB the attractive force increases by ca. 10-20% compared with SmCo.

Temperature range:

max. 80°C.

KIPP Magnets shallow pot NdFeB

Order No.	Form	D	D1	D2	D3	L	L1	Magnetic force N
K0553.01	A	6 ±0,15	-	-	-	-	4,5	5
K0553.02	A	8 ±0,15	-	-	-	-	4,5	13
K0553.03	A	10 ±0,15	-	-	-	-	4,5	25
K0553.04	A	13 ±0,15	-	-	-	-	4,5	60
K0553.05	A	16 ±0,15	-	-	-	-	4,5	95
K0553.06	A	20 ±0,15	-	-	-	-	6	140
K0553.07	A	25 ±0,15	-	-	-	-	7	200
K0553.08	A	32 ±0,20	-	-	-	-	7	350
K0553.11	B	6 ±0,15	6	M3	-	11,5	4,5	5
K0553.12	B	8 ±0,15	6	M3	-	11,5	4,5	13
K0553.13	B	10 ±0,15	6	M3	-	11,5	4,5	25
K0553.14	B	13 ±0,15	6	M3	-	11,5	4,5	60
K0553.15	B	16 ±0,15	6	M4	-	11,5	4,5	95
K0553.16	B	20 ±0,15	8	M4	-	13	6	140
K0553.17	B	25 ±0,15	8	M4	-	14	7	200
K0553.18	B	32 ±0,20	10	M5	-	15,5	7	350
K0553.23	C	10 ±0,15	-	-	M3	11,5	4,5	25
K0553.24	C	13 ±0,15	-	-	M5	12,5	4,5	60
K0553.25	C	16 ±0,15	-	-	M6	12,5	4,5	95
K0553.26	C	20 ±0,15	-	-	M6	16	6	140
K0553.27	C	25 ±0,15	-	-	M6	17	7	200
K0553.28	C	32 ±0,20	-	-	M6	17	7	350



Magnets shallow pot with counterbore

hard ferrite

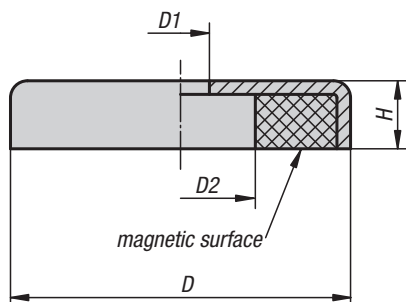

Material:
Housing, steel.
Magnetic core hard ferrite.

Version:
Housing, galvanized.

Sample order:
K0554.50

Note:
Shielded system.

Temperature range:
max. 200°C.

KIPP Magnets shallow pot with counterbore hard ferrite

Order No.	D	D1	D2	H	Magnetic force N
K0554.50	50 ±0,20	8,5	22	10	180
K0554.63	63 ±0,20	6,5	24	14	290
K0554.80	80 ±0,25	6,5	11,5	18	540

K0555

Magnets shallow pot with countersink

hard ferrite

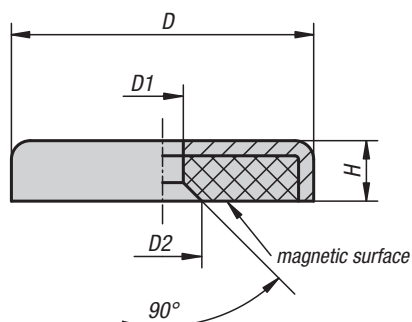

Material:
Housing, steel.
Magnetic core hard ferrite.

Version:
Housing, galvanized.

Sample order:
K0555.01

Note:
Shielded system.

Temperature range:
max. 200°C.

KIPP Magnets shallow pot with countersink hard ferrite

Order No.	D	D1	D2	H	Magnetic force N
K0555.01	16 ±0,15	3,3	7	4,5	14
K0555.02	20 ±0,15	4,2	9	6	27
K0555.03	25 ±0,15	5,5	11	7	36
K0555.04	32 ±0,20	5,5	11	7	72
K0555.05	40 ±0,20	5,5	11	8	90

Magnets shallow pot with internal thread

NdFeB

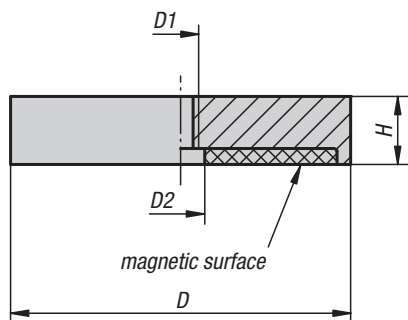

Material:
Housing, steel.
Magnetic core NdFeB.

Version:
Housing, galvanized.

Sample order:
K0556.01

Note:
Shielded system

Temperature range:
max. 80°C.

KIPP Magnets shallow pot with internal thread NdFeB

Order No.	D	D1	D2	H	Magnetic force N
K0556.01	32	M5	5,5	7	330
K0556.02	40	M5	10,5	8	550
K0556.03	63	M10	11,7	14	1.100
K0556.04	75	M10	13	15	1.750

K0557

Magnets deep pot

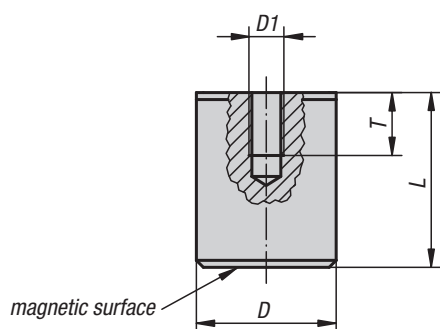

Material:
Housing, steel.
Magnetic core AlNiCo.

Version:
Housing painted red.

Sample order:
K0557.01

Note:
Hard magnet in aluminium housing and steel jacket.
Shielded system. Pot magnets are used for retaining,
lifting and mounting in fixtures.

Temperature range:
max. 450°C.

KIPP Magnets deep pot

Order No.	D	D1	L	T	Magnetic force N
K0557.01	17	M6	16	4	18
K0557.02	21	M6	19	5	28
K0557.03	27	M6	25	6	65
K0557.04	35	M6	30	9	115
K0557.05	65	M12	43	13	400

Magnets shallow pot

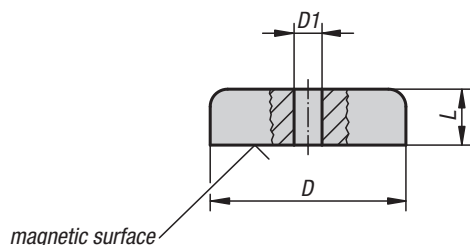

Material:
Housing, steel.
Magnetic core AlNiCo.

Version:
Housing painted red.

Sample order:
K0558.01

Note:
Shielded system. Shallow pot magnets are used in fixtures with minimal space.

Temperature range:
max. 450°C.

On request:
Other colours.

KIPP Magnets shallow pot

Order No.	D	D1	L	Magnetic force N
K0558.01	19	3,5	8	30
K0558.02	29	5	9	55
K0558.03	38	5	10,5	95

K0559

Magnets button

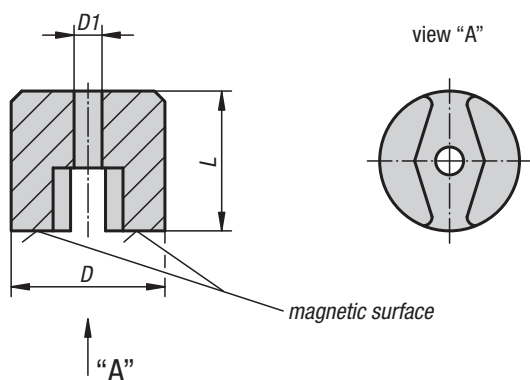

Material:
Magnetic core AlNiCo.

Version:
painted red.

Sample order:
K0559.01

Note:
Split attractive surface with through hole. Non-shielded system. Button magnets are used in laboratories, inspection rooms and for holding metal objects.

Temperature range:
max. 450°C.

KIPP Magnets button

Order No.	D	D1	L	Magnetic force N
K0559.01	13	4,2	10	7
K0559.02	19	5,4	13	19
K0559.03	25	5,4	16	29
K0559.04	32	7	25	66

Magnets strong

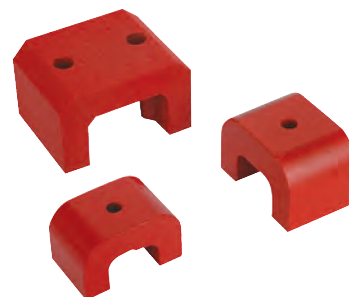
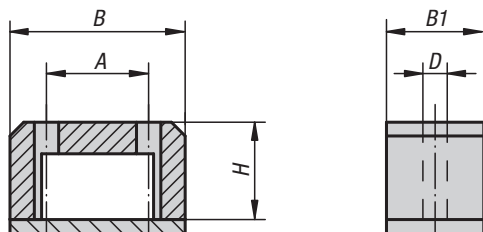

Material:
Magnetic core AlNiCo.

Version:
painted red.

Sample order:
K0560.01

Note:
Horseshoe magnets with high attractive force. Non-shielded system. The magnets are supplied with a galvanised protective plating and are used for holding, sorting and lifting. Sizes 1, 2 and 3 have only one attachment hole in the centre.

Temperature range:
max. 450°C.

KIPP Magnets strong

Order No.	Size	A	B	B1	D	H	Magnetic force N
K0560.01	1	-	30	20	5	20	45
K0560.02	2	-	40	25	5	25	90
K0560.03	3	-	45	29	5	30	120
K0560.04	4	32	57	45	8	35	230
K0560.05	5	38	70	57	8	41	320

K0561

Protective rubber caps

for shallow pot magnets

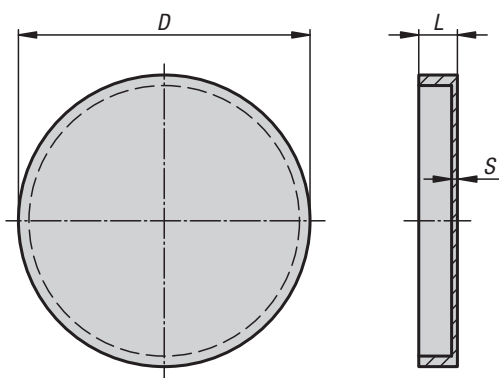

Material:
Synthetic rubber.

Version:
black.

Sample order:
K0561.50

Note:
For protecting sensitive surfaces. The rubber protective caps are slipped over the magnetic surfaces. The shear force with which the magnet can be displaced is doubled and achieves almost the original attractive force of the magnet.

Temperature range:
max. 60°C.

KIPP Protective rubber caps for shallow pot magnets

Order No.	D	L	S
K0561.50	52	6	0,5
K0561.63	65	8	0,5
K0561.80	83	11	0,5



Magnets shallow pot with internal thread

NdFeB, with rubber protective jacket

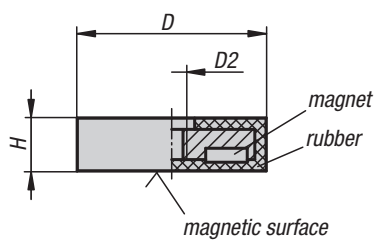
Material:

Housing, steel.

Magnetic core NdFeB (neodym).

Protective rubber jacket, synthetic rubber.

Version:

Housing, galvanized.

Black protective rubber jacket.

Sample order:

K0562.01

Note:

Shallow pot magnet with internal thread. Shielded system. With rubber protective jacket for protecting sensitive surfaces. The coefficient of friction is increased by the rubber jacket so that high lateral friction is achieved.

Temperature range:

max. 60°C.

KIPP Magnets shallow pot with internal thread NdFeB, with rubber protective jacket

Order No.	D	D2	H	Magnetic force N
K0562.01	22	M4	6	35
K0562.02	31	M5	6	75
K0562.03	43	M4	6	85
K0562.04	66	M6	8,5	180
K0562.05	88	M6	8	420

Magnets shallow pot with tapped pin

NdFeB, with rubber protective jacket

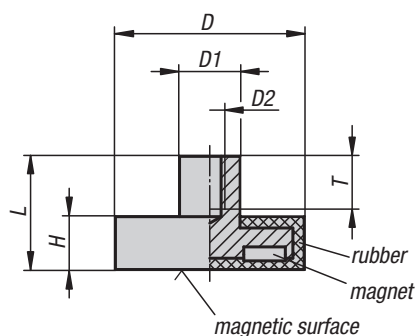
Material:

Housing, steel.

Magnetic core NdFeB (neodym).

Protective rubber jacket, synthetic rubber.

Version:

Housing, galvanized.

Black protective rubber jacket.

Sample order:

K0563.01

Note:

Shallow pot magnets with tapped pin, shielded system. With rubber protective jacket for protecting sensitive surfaces. The coefficient of friction is increased by the rubber jacket so that high lateral friction is achieved.

Temperature range:

max. 60°C.

KIPP Magnets shallow pot with tapped pin NdFeB, with rubber protective jacket

Order No.	D	D1	D2	H	L	T	Magnetic force N
K0563.01	12	8	M4	7	14,8	6	10
K0563.02	22	8	M4	6	11,5	6	50
K0563.03	31	8	M4	6	11,5	5	75
K0563.04	43	8	M4	6	10,5	5	85
K0563.05	66	10	M5	8,2	15	8	180
K0563.06	88	12	M8	8,2	17	11	420



Magnets shallow pot with threaded pin

NdFeB, with rubber protective jacket

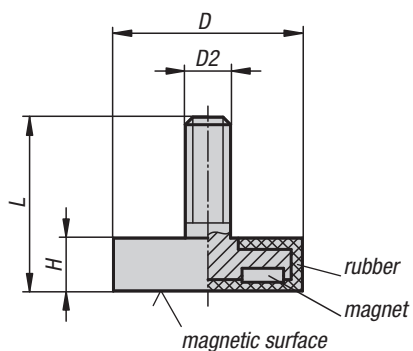
Material:

Housing, steel.

Magnetic core NdFeB (neodym).

Protective rubber jacket, synthetic rubber.

Version:

Housing, galvanized.

Black protective rubber jacket.

Sample order:

K0564.01

Note:

Shallow pot magnets with threaded pin, shielded system. With rubber protective jacket for protecting sensitive surfaces. The coefficient of friction is increased by the rubber jacket, so that high lateral friction is achieved.

Temperature range:

max. 60°C

KIPP Magnets shallow pot with threaded pin NdFeB, with rubber protective jacket

Order No.	D	D2	H	L	Magnetic force N
K0564.01	22	M4	6	12,5	50
K0564.02	43	M6	6	21	85
K0564.03	66	M8	8,2	23	180
K0564.04	88	M8	8,2	23,5	420

Magnets shallow pot with through hole

NdFeB, with rubber protective jacket

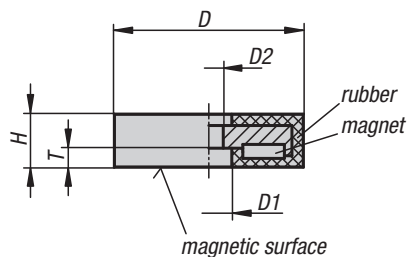

Material:

Housing, steel.

Magnetic core NdFeB (neodym).

Protective rubber jacket, synthetic rubber.

Version:

Housing, galvanized.

Black protective rubber jacket.

Sample order:

K0565.01

Note:

Shallow pot magnets, shielded system. With rubber protective jacket for protecting sensitive surfaces. The coefficient of friction is increased by the rubber jacket so that high lateral friction is achieved.

Temperature range:

max. 60°C.



KIPP Magnets shallow pot with through hole NdFeB, with rubber protective jacket

Order No.	D	D1	D2	H	T	Magnetic force N
K0565.01	22	8	4	6	3,5	35
K0565.02	31	9	6	6	3,5	75
K0565.03	43	12,8	7	6	4,2	85
K0565.04	57	25,3	8	7,6	3,3	175
K0565.05	66	22	5,5	8,5	3,2	210

