

Indexing plungers

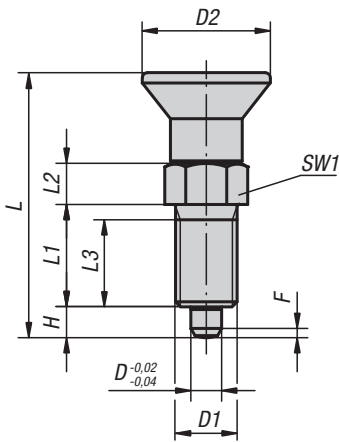

Form A
non-lockout type
without locknut



Form B
non-lockout type
with locknut

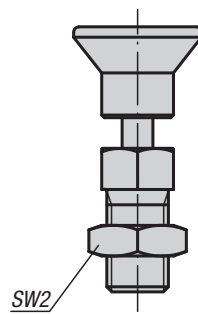

Form C
lockout type
without locknut

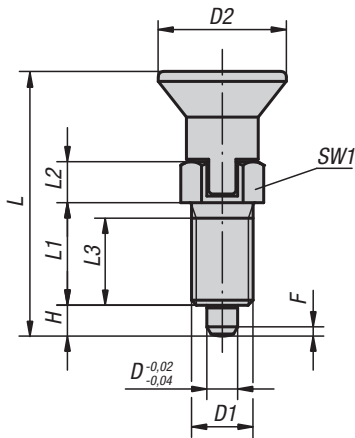

Form D
lockout type
with locknut

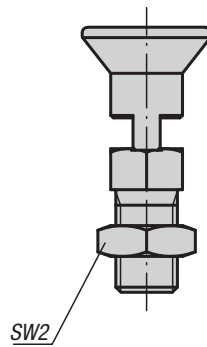

Material:

Steel version:
Indexing pin hardened:
grade 5.8.

Stainless steel version,
Indexing pin hardened
Threaded sleeve 1.4305
Indexing pin 1.4034

Indexing pin not hardened
Threaded sleeve 1.4305
Indexing pin 1.4305

Mushroom knob black grey thermoplastic

Version:

Steel version:
Indexing pin hardened, ground, black oxidised.

Stainless steel version:
Indexing pin hardened, ground and bright.
Indexing pin not hardened, ground and bright.

Sample order:

K0338.04206

Note:

Indexing plungers are used to prevent any change in locking position due to lateral forces. A new locking position can only be set after the pin has been manually disengaged. Form C or D is recommended for applications where the plunger remains disengaged over a long period and the pin should be prevented from springing back.

On request:

Special versions.

Accessories:

Spacer rings K0665

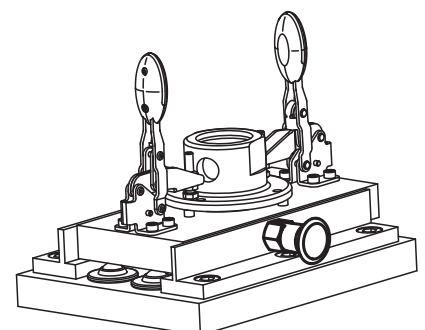

Indexing plungers



KIPP Indexing plungers, steel, indexing pin hardened

Order No. Form A	Order No. Form B	Order No. Form C	Order No. Form D	D	D1	D2	L	L1	L2	L3	H	SW1	SW2	F x 30°	Spring force initial pressure F1 approx. N	Spring force final pressure F2 approx. N
K0338.1903	K0338.2903	K0338.3903	K0338.4903	3	M6x0,75	14	31,5	12	5	10	3,5	8	-/10-/10	0,8	4,5	10
K0338.1004	K0338.2004	K0338.3004	K0338.4004	4	M8x1	18	38,5	15	6	13	4	10	-/13-/13	1	6	12
K0338.1105	K0338.2105	K0338.3105	K0338.4105	5	M10x1	21	43,5	17	7	15	5	13	-/17-/17	1,3	5	12
K0338.1206	K0338.2206	K0338.3206	K0338.4206	6	M12x1,5	25	51,7	20	8	17	6	14	-/19-/19	1,8	6	14
K0338.1308	K0338.2308	K0338.3308	K0338.4308	8	M16x1,5	33	68	26	10	23	8	19	-/24-/24	2,3	15	35
K0338.1410	K0338.2410	K0338.3410	K0338.4410	10	M20x1,5	33	74	28	12	25	10	22	-/30-/30	2,8	15	34
K0338.1412	K0338.2412	K0338.3412	K0338.4412	12	M20x1,5	33	78	28	14	25	12	22	-/30-/30	2,8	15	39
K0338.1516	K0338.2516	K0338.3516	K0338.4516	16	M24x2	40	96	32	18	28	16	27	-/36-/36	3,2	20	46

KIPP Indexing plungers, stainless steel, indexing pin hardened

Order No. Form A	Order No. Form B	Order No. Form C	Order No. Form D	D	D1	D2	L	L1	L2	L3	H	SW1	SW2	F x 30°	Spring force initial pressure F1 approx. N	Spring force final pressure F2 approx. N
K0338.01903	K0338.02903	K0338.03903	K0338.04903	3	M6x0,75	14	31,5	12	5	10	3,5	8	-/10-/10	0,8	4,5	10
K0338.01004	K0338.02004	K0338.03004	K0338.04004	4	M8x1	18	38,5	15	6	13	4	10	-/13-/13	1	6	12
K0338.01105	K0338.02105	K0338.03105	K0338.04105	5	M10x1	21	43,5	17	7	15	5	13	-/17-/17	1,3	5	12
K0338.01206	K0338.02206	K0338.03206	K0338.04206	6	M12x1,5	25	51,7	20	8	17	6	14	-/19-/19	1,8	6	14
K0338.01308	K0338.02308	K0338.03308	K0338.04308	8	M16x1,5	33	68	26	10	23	8	19	-/24-/24	2,3	15	35
K0338.01410	K0338.02410	K0338.03410	K0338.04410	10	M20x1,5	33	74	28	12	25	10	22	-/30-/30	2,8	15	34
K0338.01412	K0338.02412	K0338.03412	K0338.04412	12	M20x1,5	33	78	28	14	25	12	22	-/30-/30	2,8	15	39
K0338.01516	K0338.02516	K0338.03516	K0338.04516	16	M24x2	40	96	32	18	28	16	27	-/36-/36	3,2	20	46

KIPP Indexing plungers, stainless steel, indexing pin not hardened

Order No. Form A	Order No. Form B	Order No. Form C	Order No. Form D	D	D1	D2	L	L1	L2	L3	H	SW1	SW2	F x 30°	Spring force initial pressure F1 approx. N	Spring force final pressure F2 approx. N
K0338.11903	K0338.12903	K0338.13903	K0338.14903	3	M6x0,75	14	31,5	12	5	10	3,5	8	-/10-/10	0,8	4,5	10
K0338.11004	K0338.12004	K0338.13004	K0338.14004	4	M8x1	18	38,5	15	6	13	4	10	-/13-/13	1	6	12
K0338.11105	K0338.12105	K0338.13105	K0338.14105	5	M10x1	21	43,5	17	7	15	5	13	-/17-/17	1,3	5	12
K0338.11206	K0338.12206	K0338.13206	K0338.14206	6	M12x1,5	25	51,7	20	8	17	6	14	-/19-/19	1,8	6	14
K0338.11308	K0338.12308	K0338.13308	K0338.14308	8	M16x1,5	33	68	26	10	23	8	19	-/24-/24	2,3	15	35
K0338.11410	K0338.12410	K0338.13410	K0338.14410	10	M20x1,5	33	74	28	12	25	10	22	-/30-/30	2,8	15	34
K0338.11412	K0338.12412	K0338.13412	K0338.14412	12	M20x1,5	33	78	28	14	25	12	22	-/30-/30	2,8	15	39
K0338.11516	K0338.12516	K0338.13516	K0338.14516	16	M24x2	40	96	32	18	28	16	27	-/36-/36	3,2	20	46



Indexing plungers

with extended indexing pin



Form A
non-lockout type
without locknut

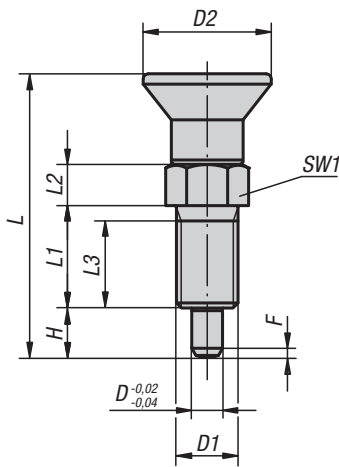

Form B
non-lockout type
with locknut

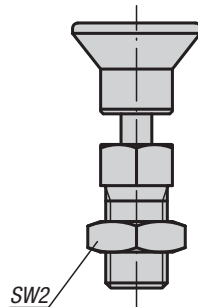

Form C
lockout type
without locknut

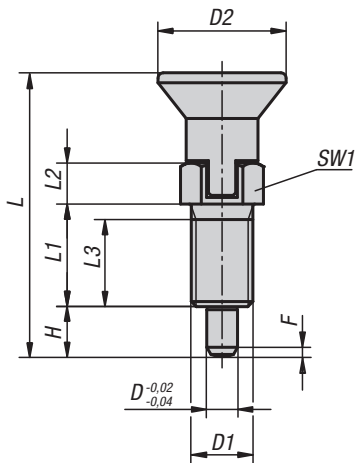

Form D
lockout type
with locknut

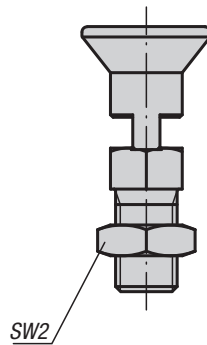

Material:

Steel version:
Indexing pin hardened:
grade 5.8.

Stainless steel version,
Indexing pin hardened
Threaded sleeve 1.4305
Indexing pin 1.4034

Indexing pin not hardened
Threaded sleeve 1.4305
Indexing pin 1.4305

Mushroom knob black grey thermoplastic

Version:

Steel version:
Indexing pin hardened, ground, black oxidised.

Stainless steel version:
Indexing pin hardened, ground and bright.
Indexing pin not hardened, ground and bright.

Sample order:

K0630.21903

Note:

Indexing plungers are used to prevent any change in locking position due to lateral forces. A new locking position can only be set after the pin has been manually disengaged.

On request:

Special versions.

Accessories:

Spacer rings K0665

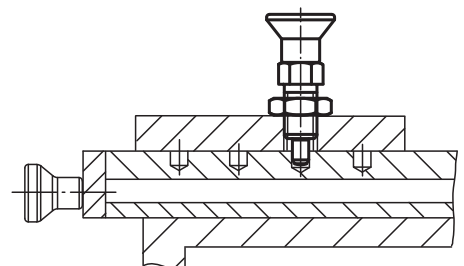

KIPP Indexing plungers with extended indexing pins, steel, indexing pins hardened

Order No. Form A	Order No. Form B	D	D1	D2	L	L1	L2	L3	H	SW1	SW2	F x 30°	Spring force initial pressure F1 approx. N	Spring force final pressure F2 approx. N
K0630.21903	K0630.22903	3	M6x0,75	14	33	12	5	10	5	8	-/10	0,8	4,5	12
K0630.21004	K0630.22004	4	M8x1	18	40,5	15	6	13	6	10	-/13	1	6	15
K0630.21105	K0630.22105	5	M10x1	21	46,5	17	7	15	8	13	-/17	1,3	5	16
K0630.21206	K0630.22206	6	M12x1,5	25	54,7	20	8	17	9	14	-/19	1,8	6	18
K0630.21308	K0630.22308	8	M16x1,5	33	72	26	10	23	12	19	-/24	2,3	15	45
K0630.21410	K0630.22410	10	M20x1,5	33	79	28	12	25	15	22	-/30	2,8	15	43
K0630.21412	K0630.22412	12	M20x1,5	33	84	28	14	25	18	22	-/30	2,8	15	51
K0630.21516	K0630.22516	16	M24x2	40	104	32	18	28	24	27	-/36	3,2	20	60

Order No. Form C	Order No. Form D	D	D1	D2	L	L1	L2	L3	H	SW1	SW2	F x 30°	Spring force initial pressure F1 approx. N	Spring force final pressure F2 approx. N
K0630.23105	K0630.24105	5	M10x1	21	49,5	17	10	15	8	13	-/17	1,3	5	16
K0630.23206	K0630.24206	6	M12x1,5	25	57,7	20	11	17	9	14	-/19	1,8	6	18
K0630.23308	K0630.24308	8	M16x1,5	33	76	26	14	23	12	19	-/24	2,3	15	45

KIPP Indexing plungers with extended indexing pins, stainless steel, indexing pins hardened

Order No. Form A	Order No. Form B	D	D1	D2	L	L1	L2	L3	H	SW1	SW2	F x 30°	Spring force initial pressure F1 approx. N	Spring force final pressure F2 approx. N
K0630.201903	K0630.202903	3	M6x0,75	14	33	12	5	10	5	8	-/10	0,8	4,5	12
K0630.201004	K0630.202004	4	M8x1	18	40,5	15	6	13	6	10	-/13	1	6	15
K0630.201105	K0630.202105	5	M10x1	21	46,5	17	7	15	8	13	-/17	1,3	5	16
K0630.201206	K0630.202206	6	M12x1,5	25	54,7	20	8	17	9	14	-/19	1,8	6	18
K0630.201308	K0630.202308	8	M16x1,5	33	72	26	10	23	12	19	-/24	2,3	15	45
K0630.201410	K0630.202410	10	M20x1,5	33	79	28	12	25	15	22	-/30	2,8	15	43
K0630.201412	K0630.202412	12	M20x1,5	33	84	28	14	25	18	22	-/30	2,8	15	51
K0630.201516	K0630.202516	16	M24x2	40	104	32	18	28	24	27	-/36	3,2	20	60

Order No. Form C	Order No. Form D	D	D1	D2	L	L1	L2	L3	H	SW1	SW2	F x 30°	Spring force initial pressure F1 approx. N	Spring force final pressure F2 approx. N
K0630.203105	K0630.204105	5	M10x1	21	49,5	17	10	15	8	13	-/17	1,3	5	16
K0630.203206	K0630.204206	6	M12x1,5	25	57,7	20	11	17	9	14	-/19	1,8	6	18
K0630.203308	K0630.204308	8	M16x1,5	33	76	26	14	23	12	19	-/24	2,3	15	45

KIPP Indexing plungers with extended indexing pins, stainless steel, indexing pins not hardened

Order No. Form A	Order No. Form B	D	D1	D2	L	L1	L2	L3	H	SW1	SW2	F x 30°	Spring force initial pressure F1 approx. N	Spring force final pressure F2 approx. N
K0630.211903	K0630.212903	3	M6x0,75	14	33	12	5	10	5	8	-/10	0,8	4,5	12
K0630.211004	K0630.212004	4	M8x1	18	40,5	15	6	13	6	10	-/13	1	6	15
K0630.211105	K0630.212105	5	M10x1	21	46,5	17	7	15	8	13	-/17	1,3	5	16
K0630.211206	K0630.212206	6	M12x1,5	25	54,7	20	8	17	9	14	-/19	1,8	6	18
K0630.211308	K0630.212308	8	M16x1,5	33	72	26	10	23	12	19	-/24	2,3	15	45
K0630.211410	K0630.212410	10	M20x1,5	33	79	28	12	25	15	22	-/30	2,8	15	43
K0630.211412	K0630.212412	12	M20x1,5	33	84	28	14	25	18	22	-/30	2,8	15	51
K0630.211516	K0630.212516	16	M24x2	40	104	32	18	28	24	27	-/36	3,2	20	60

Order No. Form C	Order No. Form D	D	D1	D2	L	L1	L2	L3	H	SW1	SW2	F x 30°	Spring force initial pressure F1 approx. N	Spring force final pressure F2 approx. N
K0630.213105	K0630.214105	5	M10x1	21	49,5	17	10	15	8	13	-/17	1,3	5	16
K0630.213206	K0630.214206	6	M12x1,5	25	57,7	20	11	17	9	14	-/19	1,8	6	18
K0630.213308	K0630.214308	8	M16x1,5	33	76	26	14	23	12	19	-/24	2,3	15	45

Indexing plungers

short version



Form A
non-lockout type
without locknut

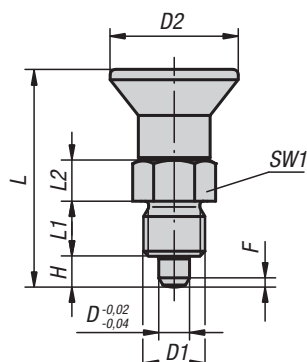

Form B
non-lockout type
with locknut

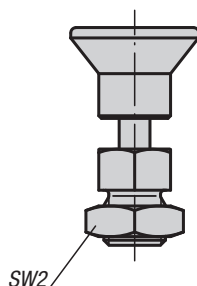

Form C
lockout type
without locknut

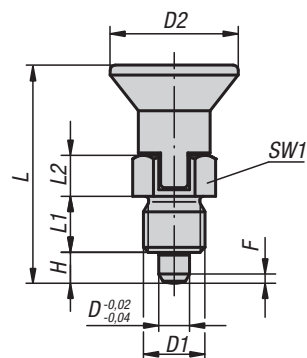

Form D
lockout type
with locknut

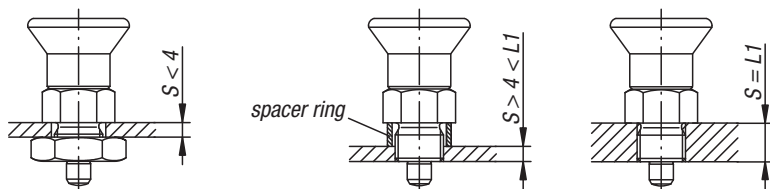
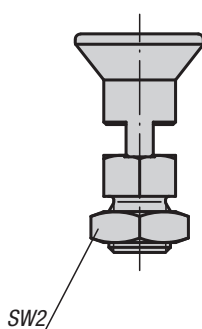

Material:

Steel version:
Indexing pin hardened:
grade 5.8

Stainless steel version:
Indexing pin not hardened
Threaded sleeve 1.4305
Indexing pin 1.4305

Mushroom knob black grey thermoplastic.

Version:

Steel version:
Indexing pin hardened, ground, black oxidised.

Stainless steel version:
Indexing pin not hardened, ground, bright.

Sample order:

K0631.16206

Note:

Indexing plungers are used to prevent any change in position due to lateral forces. A new locking position can only be set after the pin has been manually disengaged. Form C or D is recommended for applications in which the pin is disengaged over extended periods and should be prevented from springing back.

On request:

Special versions.

Accessories:

Spacer rings K0665

KIPP Indexing plungers, short version, steel, indexing pin hardened

Order No. Form A	Order No. Form B	Order No. Form C	Order No. Form D	D	D1	D2	L	L1	L2	H	SW1	SW2	F x 30°	Spring force initial pressure F1 approx. N	Spring force final pressure F2 approx. N
K0631.5903	K0631.6903	K0631.7903	K0631.8903	3	M6x0,75	14	25,5	6	5	3,5	8	- / 10 / - / 10	0,8	4	10
K0631.5004	K0631.6004	K0631.7004	K0631.8004	4	M8x1	18	29,5	6	6	4	10	- / 13 / - / 13	1	4	12
K0631.5105	K0631.6105	K0631.7105	K0631.8105	5	M10x1	21	34,5	8	7	5	13	- / 17 / - / 17	1,3	5	12
K0631.5206	K0631.6206	K0631.7206	K0631.8206	6	M12x1,5	25	41,7	10	8	6	14	- / 19 / - / 19	1,8	6	14
K0631.5308	K0631.6308	K0631.7308	K0631.8308	8	M16x1,5	33	54	12	10	8	19	- / 24 / - / 24	2,3	14	28
K0631.5410	K0631.6410	K0631.7410	K0631.8410	10	M20x1,5	33	61	15	12	10	22	- / 30 / - / 30	2,8	15	32

KIPP Indexing plungers, short version, stainless steel, indexing pin not hardened

Order No. Form A	Order No. Form B	Order No. Form C	Order No. Form D	D	D1	D2	L	L1	L2	H	SW1	SW2	F x 30°	Spring force initial pressure F1 approx. N	Spring force final pressure F2 approx. N
K0631.15903	K0631.16903	K0631.17903	K0631.18903	3	M6x0,75	14	25,5	6	5	3,5	8	- / 10 / - / 10	0,8	4	10
K0631.15004	K0631.16004	K0631.17004	K0631.18004	4	M8x1	18	29,5	6	6	4	10	- / 13 / - / 13	1	4	12
K0631.15105	K0631.16105	K0631.17105	K0631.18105	5	M10x1	21	34,5	8	7	5	13	- / 17 / - / 17	1,3	5	12
K0631.15206	K0631.16206	K0631.17206	K0631.18206	6	M12x1,5	25	41,7	10	8	6	14	- / 19 / - / 19	1,8	6	14
K0631.15308	K0631.16308	K0631.17308	K0631.18308	8	M16x1,5	33	54	12	10	8	19	- / 24 / - / 24	2,3	14	28
K0631.15410	K0631.16410	K0631.17410	K0631.18410	10	M20x1,5	33	61	15	12	10	22	- / 30 / - / 30	2,8	15	32

Indexing plungers stainless steel



Form A
non-lockout type
without locknut

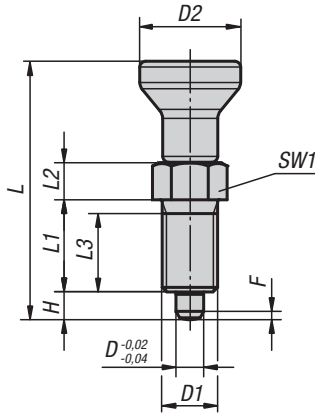

Form B
non-lockout type
with locknut

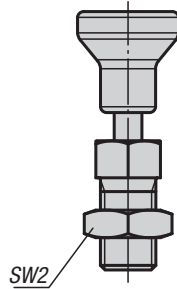

Form C
lockout type
without locknut

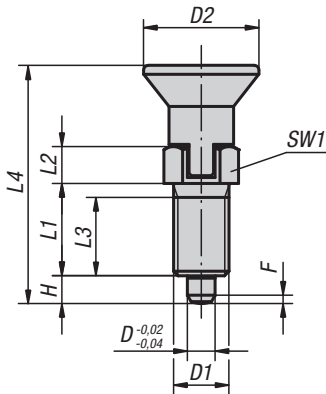

Form D
lockout type
with locknut

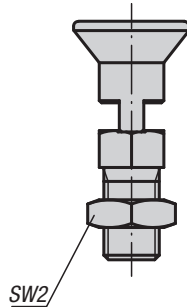

Material:

Indexing pin hardened:
Threaded sleeve 1.4305.
Indexing pin 1.4034.

Indexing pin not hardened:
Threaded sleeve 1.4305.
Indexing pin 1.4305.

Mushroom knob 1.4305, electrolytic-polish.

Version:

Bright.
Indexing pin ground.

Sample order:

K0632.001004

Note:

Indexing plungers are used to prevent any change in locking position due to lateral forces. A new locking position can only be set after the pin has been manually disengaged. Form C or D is recommended for applications in which the pin is disengaged over extended periods and should be prevented from springing back.

On request:

Special versions.

Accessories:

Spacer rings K0665

KIPP Indexing plungers stainless steel, indexing pin hardened

Order No. Form A	Order No. Form B	Order No. Form C	Order No. Form D	D	D1	D2	L	L1	L2	L3	L4	H	SW1	SW2	F x 30°	Spring force initial pressure F1 approx. N	Spring force final pressure F2 approx. N
K0632.001903	K0632.002903	K0632.003903	K0632.004903	3	M6x0,75	14	34,5/34,5/-/-	12	5	10	-/-/31,5/31,5	3,5	8	-/10/-/10	0,8	4,5	10
K0632.001004	K0632.002004	K0632.003004	K0632.004004	4	M8x1	18	43/43/-/-	15	6	13	-/-/38,5/38,5	4	10	-/13/-/13	1	6	12
K0632.001105	K0632.002105	K0632.003105	K0632.004105	5	M10x1	21	50/50/-/-	17	7	15	-/-/43,5/43,5	5	13	-/17/-/17	1,3	5	12
K0632.001206	K0632.002206	K0632.003206	K0632.004206	6	M12x1,5	25	59/59/-/-	20	8	17	-/-/51,7/51,7	6	14	-/19/-/19	1,8	6	14
K0632.001308	K0632.002308	K0632.003308	K0632.004308	8	M16x1,5	33	77/77/-/-	26	10	23	-/-/68/68	8	19	-/24/-/24	2,3	15	35
K0632.001410	K0632.002410	K0632.003410	K0632.004410	10	M20x1,5	33	83/83/-/-	28	12	25	-/-/74/74	10	22	-/30/-/30	2,8	15	34
K0632.001412	K0632.002412	K0632.003412	K0632.004412	12	M20x1,5	33	87/87/-/-	28	14	25	-/-/78/78	12	22	-/30/-/30	2,8	15	39
K0632.001516	K0632.002516	K0632.003516	K0632.004516	16	M24x2	40	106/106/-/-	32	18	28	-/-/96/96	16	27	-/36/-/36	3,2	20	46

KIPP Indexing plungers stainless steel, indexing pin not hardened

Order No. Form A	Order No. Form B	Order No. Form C	Order No. Form D	D	D1	D2	L	L1	L2	L3	L4	H	SW1	SW2	F x 30°	Spring force initial pressure F1 approx. N	Spring force final pressure F2 approx. N
K0632.111903	K0632.112903	K0632.113903	K0632.114903	3	M6x0,75	14	34,5/34,5/-/-	12	5	10	-/-/31,5/31,5	3,5	8	-/10/-/10	0,8	4,5	10
K0632.111004	K0632.112004	K0632.113004	K0632.114004	4	M8x1	18	43/43/-/-	15	6	13	-/-/38,5/38,5	4	10	-/13/-/13	1	6	12
K0632.111105	K0632.112105	K0632.113105	K0632.114105	5	M10x1	21	50/50/-/-	17	7	15	-/-/43,5/43,5	5	13	-/17/-/17	1,3	5	12
K0632.111206	K0632.112206	K0632.113206	K0632.114206	6	M12x1,5	25	59/59/-/-	20	8	17	-/-/51,7/51,7	6	14	-/19/-/19	1,8	6	14
K0632.111308	K0632.112308	K0632.113308	K0632.114308	8	M16x1,5	33	77/77/-/-	26	10	23	-/-/68/68	8	19	-/24/-/24	2,3	15	35
K0632.111410	K0632.112410	K0632.113410	K0632.114410	10	M20x1,5	33	83/83/-/-	28	12	25	-/-/74/74	10	22	-/30/-/30	2,8	15	34
K0632.111412	K0632.112412	K0632.113412	K0632.114412	12	M20x1,5	33	87/87/-/-	28	14	25	-/-/78/78	12	22	-/30/-/30	2,8	15	39
K0632.111516	K0632.112516	K0632.113516	K0632.114516	16	M24x2	40	106/106/-/-	32	18	28	-/-/96/96	16	27	-/36/-/36	3,2	20	46

Indexing plungers

for thin-walled parts



Form A
non-lockout type

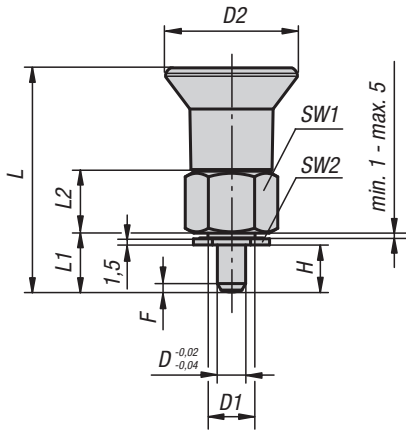

mounting hole

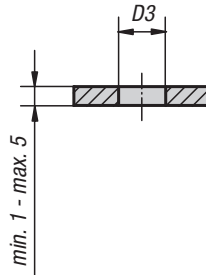

Form C
lockout type

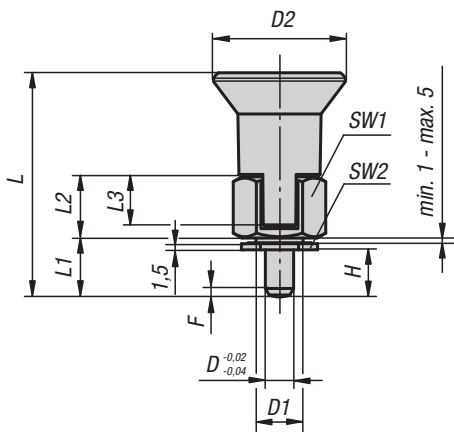

accessory

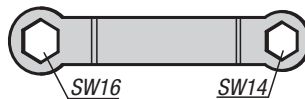

Material:

Steel version:
Indexing pin hardened:
grade 5.8

Stainless steel version:
Indexing pin not hardened
Threaded sleeve 1.4305
Indexing pin 1.4305

Mushroom knob black grey thermoplastic.

Version:

Steel version:
Indexing pin hardened, ground, black oxidised.

Stainless steel version:
Indexing pin not hardened, ground, bright.

Sample order:

K0735.31105 (indexing plunger)
K0631.91416 (double-ended ring spanner)

Note:

These indexing plungers are especially well-suited for assembly in thin-walled parts. Indexing plungers are used where any change in locking position due to lateral forces should be prevented. A new locking position can be set only after the pin has been manually disengaged. Form C is recommended for applications where the locking pin should remain disengaged for an extended period and be prevented from springing back.

Accessories:

A double-ended ring spanner can be supplied as an accessory to tighten the nut.

KIPP Indexing plungers for thin-walled parts, steel, indexing pin hardened

Order No.	Form	D	D1	D2	D3	L	L1	L2	L3	H	SW1	SW2	F x 30°	Spring force initial pressure F1 approx. N	Spring force final pressure F2 approx. N	Article number double-ended ring spanner
K0735.31105	A	5	M10x1	28	10	46,5	11,5	13	10,5	5-9	17	14	1,3	6	15	K0631.91416
K0735.31206	A	6	M10x1	28	10	47,5	12,5	13	10,5	6-10	17	14	1,8	7	19	K0631.91416
K0735.33105	C	5	M10x1	28	10	46,5	11,5	13	10,5	5-9	17	14	1,3	6	15	K0631.91416
K0735.33206	C	6	M10x1	28	10	47,5	12,5	13	10,5	6-10	17	14	1,8	7	19	K0631.91416

KIPP Indexing plungers for thin-walled parts, stainless steel, indexing pin not hardened

Order No.	Form	D	D1	D2	D3	L	L1	L2	L3	H	SW1	SW2	F x 30°	Spring force initial pressure F1 approx. N	Spring force final pressure F2 approx. N	Article number double-ended ring spanner
K0735.311105	A	5	M10x1	28	10	46,5	11,5	13	10,5	5-9	17	14	1,3	6	15	K0631.91416
K0735.311206	A	6	M10x1	28	10	47,5	12,5	13	10,5	6-10	17	14	1,8	7	19	K0631.91416
K0735.313105	C	5	M10x1	28	10	46,5	11,5	13	10,5	5-9	17	14	1,3	6	15	K0631.91416
K0735.313206	C	6	M10x1	28	10	47,5	12,5	13	10,5	6-10	17	14	1,8	7	19	K0631.91416

Notes

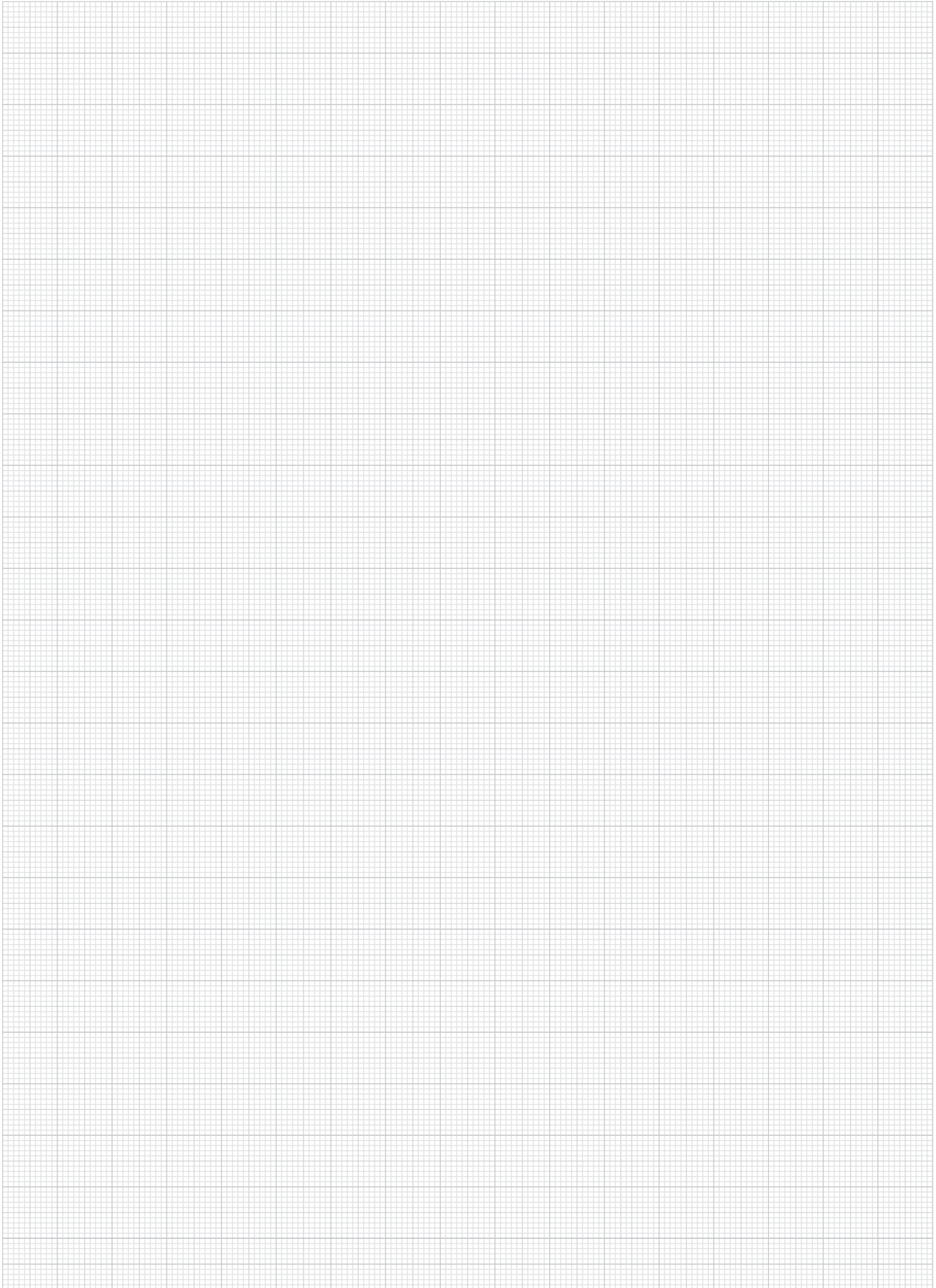

Indexing plungers



Form A
non-lockout type
without locknut

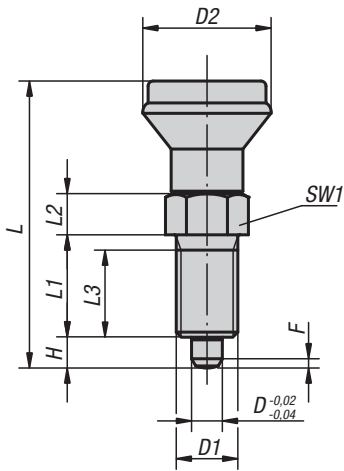

Form B
non-lockout type
with locknut

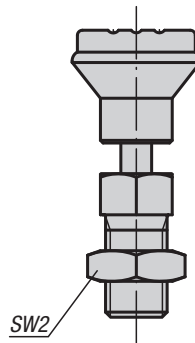

Form C
lockout type
without locknut

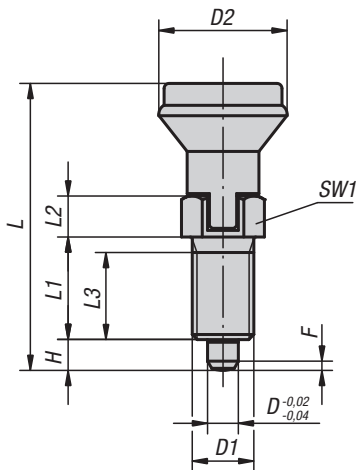

Form D
lockout type
with locknut

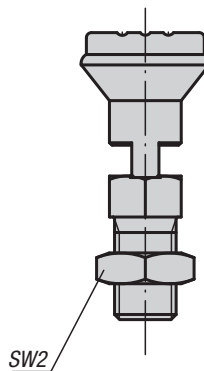

Material:

Steel version:
Indexing pin hardened:
grade 5.8.

Stainless steel version,
Indexing pin hardened
Threaded sleeve 1.4305
Indexing pin 1.4034

Indexing pin not hardened
Threaded sleeve 1.4305
Indexing pin 1.4305

Mushroom knob black grey thermoplastic

Version:

Steel version:
Indexing pin hardened, ground, black oxidised.

Stainless steel version:
Indexing pin hardened, ground and bright.
Indexing pin not hardened, ground and bright.

Sample order:

K0339.04206

Note:

Indexing plungers are used to prevent any change in locking position due to lateral forces. A new locking position can only be set after the pin has been manually disengaged. Form C or D is recommended for applications in which the pin is disengaged over extended periods and should be prevented from springing back.

On request:

Special versions.

Accessories:

Spacer rings K0665

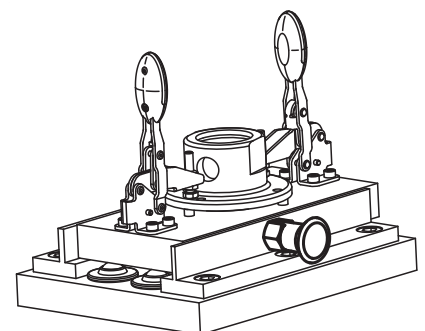

Indexing plungers



KIPP Indexing plungers, steel, indexing pin hardened

Order No. Form A	Order No. Form B	Order No. Form C	Order No. Form D	D	D1	D2	L	L1	L2	L3	H	SW1	SW2	F x 30°	Spring force initial pressure F1 approx. N	Spring force final pressure F2 approx. N
K0339.1105	K0339.2105	K0339.3105	K0339.4105	5	M10x1	21	47	17	7	15	5	13	- / 17 / - / 17	1,3	5	12
K0339.1206	K0339.2206	K0339.3206	K0339.4206	6	M12x1,5	25	56	20	8	17	6	14	- / 19 / - / 19	1,8	6	14
K0339.1308	K0339.2308	K0339.3308	K0339.4308	8	M16x1,5	33	74	26	10	23	8	19	- / 24 / - / 24	2,3	15	35
K0339.1410	K0339.2410	K0339.3410	K0339.4410	10	M20x1,5	33	80	28	12	25	10	22	- / 30 / - / 30	2,8	15	34

KIPP Indexing plungers, stainless steel, indexing pin hardened

Order No. Form A	Order No. Form B	Order No. Form C	Order No. Form D	D	D1	D2	L	L1	L2	L3	H	SW1	SW2	F x 30°	Spring force initial pressure F1 approx. N	Spring force final pressure F2 approx. N
K0339.01105	K0339.02105	K0339.03105	K0339.04105	5	M10x1	21	47	17	7	15	5	13	- / 17 / - / 17	1,3	5	12
K0339.01206	K0339.02206	K0339.03206	K0339.04206	6	M12x1,5	25	56	20	8	17	6	14	- / 19 / - / 19	1,8	6	14
K0339.01308	K0339.02308	K0339.03308	K0339.04308	8	M16x1,5	33	74	26	10	23	8	19	- / 24 / - / 24	2,3	15	35
K0339.01410	K0339.02410	K0339.03410	K0339.04410	10	M20x1,5	33	80	28	12	25	10	22	- / 30 / - / 30	2,8	15	34

KIPP Indexing plungers, stainless steel, indexing pin not hardened

Order No. Form A	Order No. Form B	Order No. Form C	Order No. Form D	D	D1	D2	L	L1	L2	L3	H	SW1	SW2	F x 30°	Spring force initial pressure F1 approx. N	Spring force final pressure F2 approx. N
K0339.11105	K0339.12105	K0339.13105	K0339.14105	5	M10x1	21	47	17	7	15	5	13	- / 17 / - / 17	1,3	5	12
K0339.11206	K0339.12206	K0339.13206	K0339.14206	6	M12x1,5	25	56	20	8	17	6	14	- / 19 / - / 19	1,8	6	14
K0339.11308	K0339.12308	K0339.13308	K0339.14308	8	M16x1,5	33	74	26	10	23	8	19	- / 24 / - / 24	2,3	15	35
K0339.11410	K0339.12410	K0339.13410	K0339.14410	10	M20x1,5	33	80	28	12	25	10	22	- / 30 / - / 30	2,8	15	34

Indexing plungers



Form A
non-lockout type
without locknut

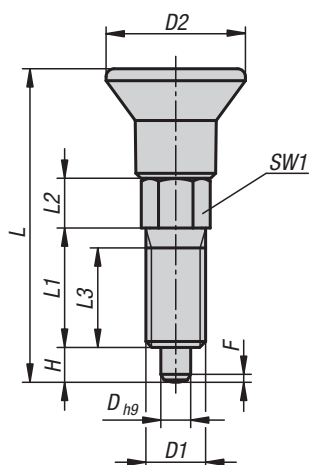

Form B
non-lockout type
with locknut

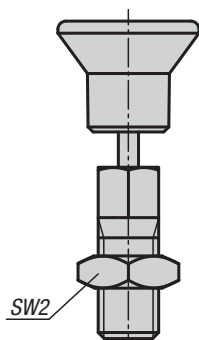

Form C
lockout type
without locknut

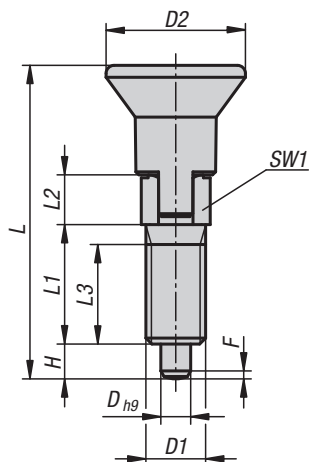

Form D
lockout type
with locknut

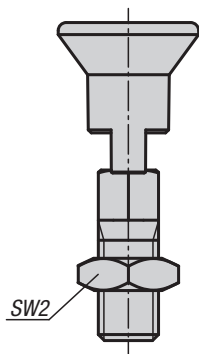

Material:

Steel version:
Indexing pin not hardened:
Threaded sleeve 1.0718.
Indexing pin 1.4305.

Stainless steel version:
Indexing pin not hardened:
Threaded sleeve 1.4305.
Indexing pin 1.4305.

Mushroom knob black grey thermoplastic.

Version:

Steel version:
Indexing pin not hardened:
Threaded sleeve, blue chromed.
Indexing pin bright.

Stainless steel version:
Indexing pin not hardened:
Steel parts bright.

Sample order:

K0747.01903060

Note:

This article is a cost-efficient alternative to the existing indexing plungers. It is suitable for applications which require less precision. The max. tightening torque should be observed when assembling.

On request:

Special versions and fine thread

KIPP Indexing plungers, steel, indexing pin not hardened

Order No. Form A	Order No. Form B	Order No. Form C	Order No. Form D	D	D1	D2	L	L1	L2	L3	H	SW1	SW2	F x 30°	Spring force initial pressure F1 approx. N	Spring force final pressure F2 approx. N	Tightening torque max. Nm
K0747.01903060	K0747.02903060	K0747.03903060	K0747.04903060	3	M6	14	31,5	12	5	10	3,5	6	- / 10 / - / 10	0,8	4	10	2
K0747.01004060	K0747.02004060	K0747.03004060	K0747.04004060	4	M6	14	36	15	6	13	4	6	- / 10 / - / 10	1	6	12	2
K0747.01105080	K0747.02105080	K0747.03105080	K0747.04105080	5	M8	14	40	17	7	15	5	8	- / 13 / - / 13	1,3	6	12	7
K0747.01206100	K0747.02206100	K0747.03206100	K0747.04206100	6	M10	18	47,5	20	8	17	6	10	- / 17 / - / 17	1,8	8	15	15
K0747.01308120	K0747.02308120	K0747.03308120	K0747.04308120	8	M12	25	61,7	26	10	23	8	12	- / 19 / - / 19	2,3	8	19	20

KIPP Indexing plungers, stainless steel, indexing pin not hardened

Order No. Form A	Order No. Form B	Order No. Form C	Order No. Form D	D	D1	D2	L	L1	L2	L3	H	SW1	SW2	F x 30°	Spring force initial pressure F1 approx. N	Spring force final pressure F2 approx. N	Tightening torque max. Nm
K0747.11903060	K0747.12903060	K0747.13903060	K0747.14903060	3	M6	14	31,5	12	5	10	3,5	6	- / 10 / - / 10	0,8	4	10	2
K0747.11004060	K0747.12004060	K0747.13004060	K0747.14004060	4	M6	14	36	15	6	13	4	6	- / 10 / - / 10	1	6	12	2
K0747.11105080	K0747.12105080	K0747.13105080	K0747.14105080	5	M8	14	40	17	7	15	5	8	- / 13 / - / 13	1,3	6	12	7
K0747.11206100	K0747.12206100	K0747.13206100	K0747.14206100	6	M10	18	47,5	20	8	17	6	10	- / 17 / - / 17	1,8	8	15	15
K0747.11308120	K0747.12308120	K0747.13308120	K0747.14308120	8	M12	25	61,7	26	10	23	8	12	- / 19 / - / 19	2,3	8	19	20

Indexing plungers

short version



Form A
non-lockout type
without locknut

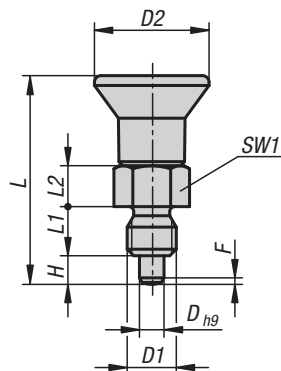

Form B
non-lockout type
with locknut

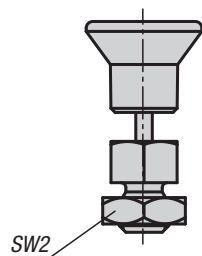

Form C
lockout type
without locknut

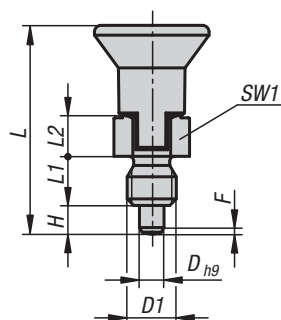

Form D
lockout type
with locknut

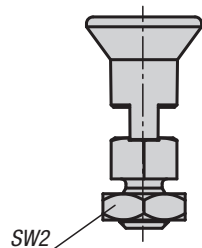

Material:

Steel version:

Indexing pin not hardened:
Threaded sleeve 1.0718.
Indexing pin 1.4305.

Stainless steel version:

Indexing pin not hardened:
Threaded sleeve 1.4305.
Indexing pin 1.4305.

Mushroom knob black grey thermoplastic.

Version:

Steel version:

Indexing pin not hardened:
Threaded sleeve, blue chromed.
Indexing pin bright.

Stainless steel version:

Indexing pin not hardened:
Steel parts bright.

Sample order:

K0748.01903060

Note:

This article is a cost-efficient alternative to the existing indexing plungers. It is suitable for applications which require less precision.

The max. tightening torque should be observed when assembling.

On request:

Special versions.



KIPP Indexing plungers short version, steel, indexing pin not hardened

Order No. Form A	Order No. Form B	Order No. Form C	Order No. Form D	D	D1	D2	L	L1	L2	H	SW1	SW2	F x 30°	Spring force initial pressure F1 approx. N	Spring force final pressure F2 approx. N	Tightening torque max. Nm
K0748.01903060	K0748.02903060	K0748.03903060	K0748.04903060	3	M6	14	25,5	6	5	3,5	8	- / 10 / - / 10	0,8	3,5	8	2
K0748.01004080	K0748.02004080	K0748.03004080	K0748.04004080	4	M8	18	29,5	6	6	4	10	- / 13 / - / 13	1	3,5	9	2
K0748.01105100	K0748.02105100	K0748.03105100	K0748.04105100	5	M10	21	34,5	8	7	5	13	- / 17 / - / 17	1,3	6	12	7
K0748.01206120	K0748.02206120	K0748.03206120	K0748.04206120	6	M12	25	41,7	10	8	6	14	- / 19 / - / 19	1,8	6	12	15
K0748.01308160	K0748.02308160	K0748.03308160	K0748.04308160	8	M16	33	54	12	10	8	19	- / 24 / - / 24	2,3	6	13	20

KIPP Indexing plungers, short version, stainless steel, indexing pin not hardened

Order No. Form A	Order No. Form B	Order No. Form C	Order No. Form D	D	D1	D2	L	L1	L2	H	SW1	SW2	F x 30°	Spring force initial pressure F1 approx. N	Spring force final pressure F2 approx. N	Tightening torque max. Nm
K0748.11903060	K0748.12903060	K0748.13903060	K0748.14903060	3	M6	14	25,5	6	5	3,5	8	- / 10 / - / 10	0,8	3,5	8	2
K0748.11004080	K0748.12004080	K0748.13004080	K0748.14004080	4	M8	18	29,5	6	6	4	10	- / 13 / - / 13	1	3,5	9	2
K0748.11105100	K0748.12105100	K0748.13105100	K0748.14105100	5	M10	21	34,5	8	7	5	13	- / 17 / - / 17	1,3	6	12	7
K0748.11206120	K0748.12206120	K0748.13206120	K0748.14206120	6	M12	25	41,7	10	8	6	14	- / 19 / - / 19	1,8	6	12	15
K0748.11308160	K0748.12308160	K0748.13308160	K0748.14308160	8	M16	33	54	12	10	8	19	- / 24 / - / 24	2,3	6	13	20

Indexing plungers

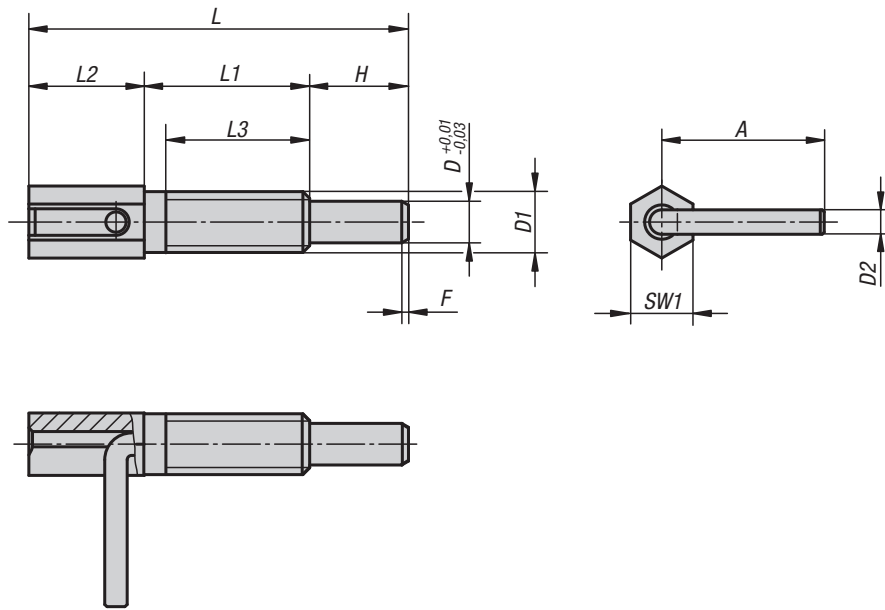

Material:
Steel grade 5.8.

Version:
Blue chromed.

Sample order:
K0340.1206

Note:
Indexing plungers are used to prevent any change in locking position due to lateral forces. A new locking position can only be set after the pin has been manually disengaged.

On request:
Special versions.

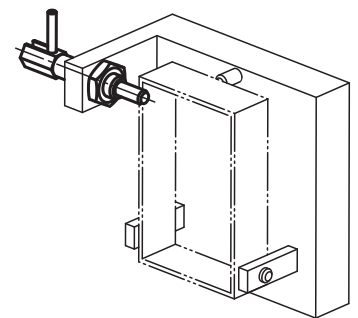

KIPP Indexing plungers

Order No.	D	D1	D2	L	L1	L2	L3	H	A	SW1	F x 30°	Spring force initial pressure F1 approx. N	Spring force final pressure F2 approx. N	Tightening torque max. Nm
K0340.1104	4	M6	2,3	41,5	20	12	17	9,5	15,5	6	0,7	3	10	1,6
K0340.1905	5	M8	3	54	27	15	24	12	19,2	8	0,9	3,5	13,5	4,5
K0340.1206	6	M10	3,5	65	33,5	17,5	30	14	22,9	10	1,1	4	16	10
K0340.1308	8	M12	4,7	73	31,8	22,2	28	19	31,2	12	1,3	4	22	13
K0340.1410	10	M16	4,7	102,5	50,5	27	44,5	25	32,7	16	1,6	4	23	42

Notes

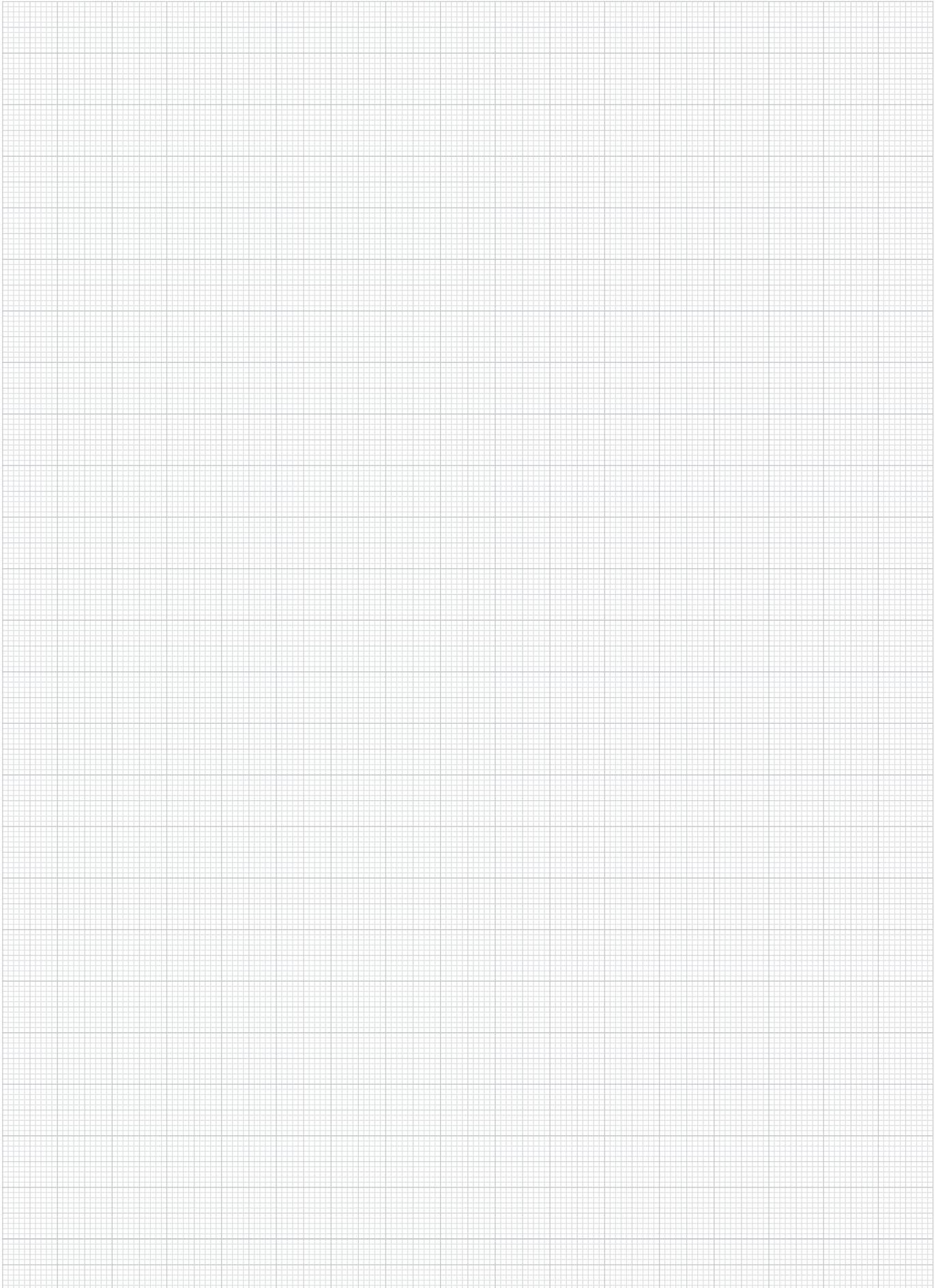

Indexing plungers

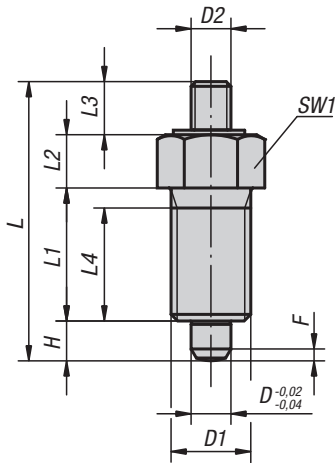

Form E
with threaded pin
without locknut

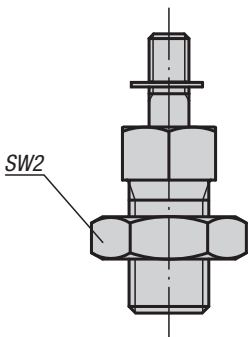

Form F
with threaded pin
with locknut

Material:

Steel version:
Indexing pin hardened:
grade 5.8.

Stainless steel version:
Indexing pin hardened:
Threaded sleeve 1.4305.
Indexing pin 1.4034.

Indexing pin not hardened:
Threaded sleeve 1.4305.
Indexing pin 1.4305.

Version:

Steel version:
Indexing pin hardened, ground, black oxidised.

Stainless steel version:
Indexing pin hardened, ground and bright.
Indexing pin not hardened, ground and bright.

Sample order:

K0341.02308

Note:

Indexing plungers are used to prevent any change in locking position due to lateral forces. A new locking position can only be set after the pin has been disengaged. Special grips can be fitted on the projecting threaded pin. This pin is also suitable for automatic actuation e.g. programme controlled pneumatic cylinder or by remote control using bowden cables.

On request:

Special versions.

Accessories:

Spacer rings K0665

example:

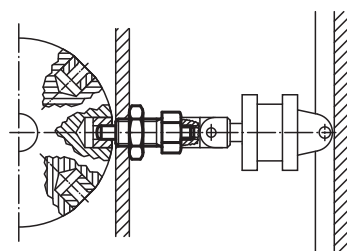

KIPP Indexing plungers, steel, indexing pin hardened

Order No. Form E	Order No. Form F	D	D1	D2	L	L1	L2	L3	L4	H	SW1	SW2	F x 30°	Spring force initial pressure F1 approx. N	Spring force final pressure F2 approx. N
K0341.1903	K0341.2903	3	M6x0,75	M2	24	12	5	3,5	10	3,5	8	- / 10	0,8	4,5	10
K0341.1004	K0341.2004	4	M8x1	M3	32	15	6	7	13	4	10	- / 13	1	6	12
K0341.1105	K0341.2105	5	M10x1	M4	37	17	7	8	15	5	13	- / 17	1,3	5	12
K0341.1206	K0341.2206	6	M12x1,5	M6	42	20	8	8	17	6	14	- / 19	1,8	6	14
K0341.1308	K0341.2308	8	M16x1,5	M8	56	26	10	12	23	8	19	- / 24	2,3	15	35
K0341.1410	K0341.2410	10	M20x1,5	M8	62	28	12	12	25	10	22	- / 30	2,8	15	34
K0341.1412	K0341.2412	12	M20x1,5	M8	66	28	14	12	25	12	22	- / 30	2,8	15	39
K0341.1516	K0341.2516	16	M24x2	M10	80	32	18	14	28	16	27	- / 36	3,2	20	46

KIPP Indexing plungers, stainless steel, indexing pin hardened

Order No. Form E	Order No. Form F	D	D1	D2	L	L1	L2	L3	L4	H	SW1	SW2	F x 30°	Spring force initial pressure F1 approx. N	Spring force final pressure F2 approx. N
K0341.01903	K0341.02903	3	M6x0,75	M2	24	12	5	3,5	10	3,5	8	- / 10	0,8	4,5	10
K0341.01004	K0341.02004	4	M8x1	M3	32	15	6	7	13	4	10	- / 13	1	6	12
K0341.01105	K0341.02105	5	M10x1	M4	37	17	7	8	15	5	13	- / 17	1,3	5	12
K0341.01206	K0341.02206	6	M12x1,5	M6	42	20	8	8	17	6	14	- / 19	1,8	6	14
K0341.01308	K0341.02308	8	M16x1,5	M8	56	26	10	12	23	8	19	- / 24	2,3	15	35
K0341.01410	K0341.02410	10	M20x1,5	M8	62	28	12	12	25	10	22	- / 30	2,8	15	34
K0341.01412	K0341.02412	12	M20x1,5	M8	66	28	14	12	25	12	22	- / 30	2,8	15	39
K0341.01516	K0341.02516	16	M24x2	M10	80	32	18	14	28	16	27	- / 36	3,2	20	46

KIPP Indexing plungers, stainless steel, indexing pin not hardened

Order No. Form E	Order No. Form F	D	D1	D2	L	L1	L2	L3	L4	H	SW1	SW2	F x 30°	Spring force initial pressure F1 approx. N	Spring force final pressure F2 approx. N
K0341.11903	K0341.12903	3	M6x0,75	M2	24	12	5	3,5	10	3,5	8	- / 10	0,8	4,5	10
K0341.11004	K0341.12004	4	M8x1	M3	32	15	6	7	13	4	10	- / 13	1	6	12
K0341.11105	K0341.12105	5	M10x1	M4	37	17	7	8	15	5	13	- / 17	1,3	5	12
K0341.11206	K0341.12206	6	M12x1,5	M6	42	20	8	8	17	6	14	- / 19	1,8	6	14
K0341.11308	K0341.12308	8	M16x1,5	M8	56	26	10	12	23	8	19	- / 24	2,3	15	35
K0341.11410	K0341.12410	10	M20x1,5	M8	62	28	12	12	25	10	22	- / 30	2,8	15	34
K0341.11412	K0341.12412	12	M20x1,5	M8	66	28	14	12	25	12	22	- / 30	2,8	15	39
K0341.11516	K0341.12516	16	M24x2	M10	80	32	18	14	28	16	27	- / 36	3,2	20	46

Indexing plungers

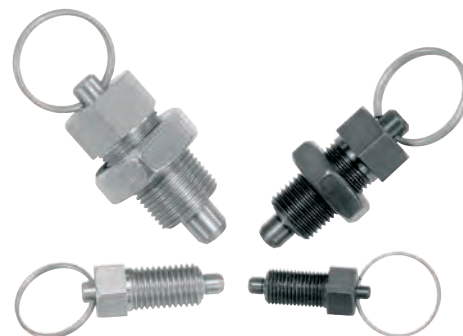
Material:

Steel version:
Indexing pin hardened:
grade 5.8.

Stainless steel version:
Indexing pin hardened:
Threaded sleeve 1.4305
Indexing pin 1.4034

Indexing pin not hardened
Threaded sleeve 1.4305
Indexing pin 1.4305

Key ring 1.4310, bright.

Version:

Steel version:
Indexing pin hardened, ground, black oxidised.

Stainless steel version:
Indexing pin hardened, ground and bright.
Indexing pin not hardened, ground and bright.

Sample order:

K0342.03308

Note:

Indexing plungers are used to prevent any change in locking position due to lateral forces. A new locking position can only be set after the pin has been disengaged. The key ring is also suitable for automatic actuation of the indexing plunger by e.g. programme-controlled pneumatic cylinder or by remote control using bowden cables.

On request:

Special versions.

Accessories:

Spacer rings K0665

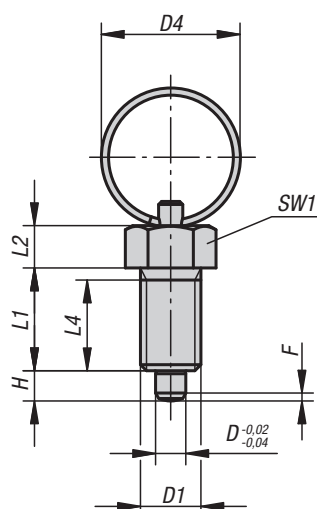

Form R
without locknut

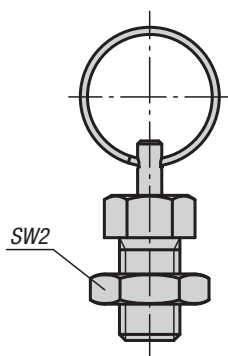

Form S
with locknut

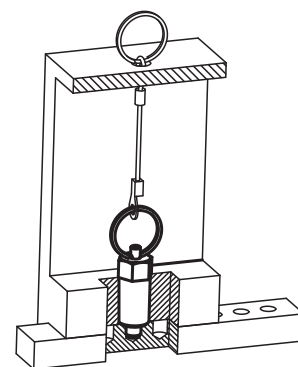

KIPP Indexing plungers, steel, indexing pin hardened

Order No. Form R	Order No. Form S	D	D1	D4	L1	L2	L4	H	SW1	SW2	F x 30°	Spring force initial pressure F1 approx. N	Spring force final pressure F2 approx. N
K0342.3004	K0342.4004	4	M8x1	15	15	6	13	4	10	- / 13	1	6	12
K0342.3105	K0342.4105	5	M10x1	23	17	7	15	5	13	- / 17	1,3	5	12
K0342.3206	K0342.4206	6	M12x1,5	23	20	8	17	6	14	- / 19	1,8	6	14
K0342.3308	K0342.4308	8	M16x1,5	28	26	10	23	8	19	- / 24	2,3	15	35
K0342.3410	K0342.4410	10	M20x1,5	28	28	12	25	10	22	- / 30	2,8	15	34

KIPP Indexing plungers, stainless steel, indexing pin hardened

Order No. Form R	Order No. Form S	D	D1	D4	L1	L2	L4	H	SW1	SW2	F x 30°	Spring force initial pressure F1 approx. N	Spring force final pressure F2 approx. N
K0342.03004	K0342.04004	4	M8x1	15	15	6	13	4	10	- / 13	1	6	12
K0342.03105	K0342.04105	5	M10x1	23	17	7	15	5	13	- / 17	1,3	5	12
K0342.03206	K0342.04206	6	M12x1,5	23	20	8	17	6	14	- / 19	1,8	6	14
K0342.03308	K0342.04308	8	M16x1,5	28	26	10	23	8	19	- / 24	2,3	15	35
K0342.03410	K0342.04410	10	M20x1,5	28	28	12	25	10	22	- / 30	2,8	15	34

KIPP Indexing plungers, stainless steel, indexing pin not hardened

Order No. Form R	Order No. Form S	D	D1	D4	L1	L2	L4	H	SW1	SW2	F x 30°	Spring force initial pressure F1 approx. N	Spring force final pressure F2 approx. N
K0342.13004	K0342.14004	4	M8x1	15	15	6	13	4	10	- / 13	1	6	12
K0342.13105	K0342.14105	5	M10x1	23	17	7	15	5	13	- / 17	1,3	5	12
K0342.13206	K0342.14206	6	M12x1,5	23	20	8	17	6	14	- / 19	1,8	6	14
K0342.13308	K0342.14308	8	M16x1,5	28	26	10	23	8	19	- / 24	2,3	15	35
K0342.13410	K0342.14410	10	M20x1,5	28	28	12	25	10	22	- / 30	2,8	15	34

Indexing plungers

without collar



Form G
without locknut

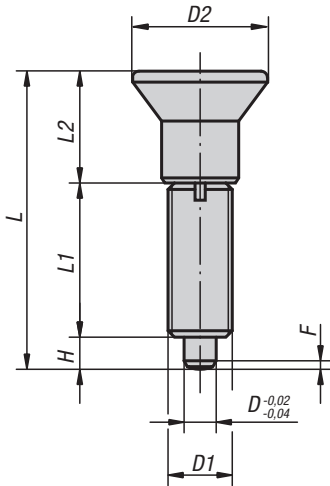

with screw-in washer

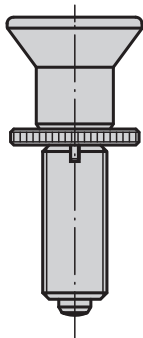

Form H
with locknut

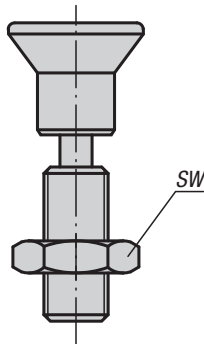

screw-in washer

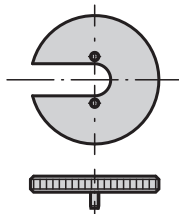

Material:

Steel version:
Indexing pin hardened:
grade 5.8.

Stainless steel version,
Indexing pin hardened
Threaded sleeve 1.4305
Indexing pin 1.4034

Indexing pin not hardened
Threaded sleeve 1.4305
Indexing pin 1.4305

Mushroom knob black grey thermoplastic

Version:

Steel version:
Indexing pin hardened, ground, black oxidised.

Stainless steel version:
Indexing pin hardened, ground and bright.
Indexing pin not hardened, ground and bright.

Sample order:

K0343.02206

Note:

Indexing plungers are used to prevent any change in locking position due to lateral forces. A new locking position can only be set after the pin has been manually disengaged. A washer is available to aid by screwing in the indexing plungers. The washer slides beneath the mushroom knob so that the carrier pins engage in the slot.

On request:

Special versions.

Accessories:

Spacer rings K0665

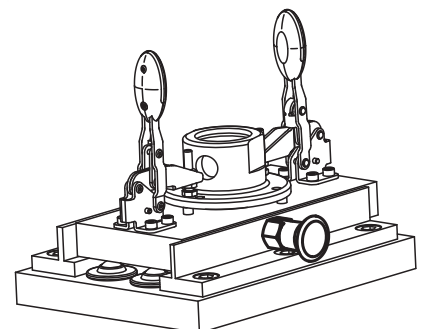

Indexing plungers

without collar



KIPP Indexing plungers without collar, steel, indexing pin hardened

Order No. Form G	Order No. Form H	D	D1	D2	L	L1	L2	H	SW	F x 30°	Spring force initial pressure F1 approx. N	Spring force final pressure F2 approx. N	Order No. screw-in washer
K0343.1903	K0343.2903	3	M6x0,75	14	31,5	17	11	3,5	- / 10	0,8	4,5	10	K0344.99
K0343.1004	K0343.2004	4	M8x1	18	38,5	21	13,5	4	- / 13	1,3	6	12	K0344.90
K0343.1105	K0343.2105	5	M10x1	21	43,5	24	14,5	5	- / 17	1,3	5	12	K0344.91
K0343.1206	K0343.2206	6	M12x1,5	25	51,7	28	17,7	6	- / 19	1,8	6	14	K0344.92
K0343.1308	K0343.2308	8	M16x1,5	33	68	36	24	8	- / 24	2,3	15	35	K0344.93
K0343.1410	K0343.2410	10	M20x1,5	33	74	40	24	10	- / 30	2,8	15	34	K0344.94
K0343.1412	K0343.2412	12	M20x1,5	33	78	42	24	12	- / 30	2,8	15	39	K0344.94
K0343.1516	K0343.2516	16	M24x2	40	96	50	30	16	- / 36	3,2	20	46	K0344.95

KIPP Indexing plungers without collar, stainless steel, indexing pin hardened

Order No. Form G	Order No. Form H	D	D1	D2	L	L1	L2	H	SW	F x 30°	Spring force initial pressure F1 approx. N	Spring force final pressure F2 approx. N	Order No. screw-in washer
K0343.01903	K0343.02903	3	M6x0,75	14	31,5	17	11	3,5	- / 10	0,8	4,5	10	K0344.99
K0343.01004	K0343.02004	4	M8x1	18	38,5	21	13,5	4	- / 13	1,3	6	12	K0344.90
K0343.01105	K0343.02105	5	M10x1	21	43,5	24	14,5	5	- / 17	1,3	5	12	K0344.91
K0343.01206	K0343.02206	6	M12x1,5	25	51,7	28	17,7	6	- / 19	1,8	6	14	K0344.92
K0343.01308	K0343.02308	8	M16x1,5	33	68	36	24	8	- / 24	2,3	15	35	K0344.93
K0343.01410	K0343.02410	10	M20x1,5	33	74	40	24	10	- / 30	2,8	15	34	K0344.94
K0343.01412	K0343.02412	12	M20x1,5	33	78	42	24	12	- / 30	2,8	15	39	K0344.94
K0343.01516	K0343.02516	16	M24x2	40	96	50	30	16	- / 36	3,2	20	46	K0344.95

KIPP Indexing plungers without collar, stainless steel, indexing pin not hardened

Order No. Form G	Order No. Form H	D	D1	D2	L	L1	L2	H	SW	F x 30°	Spring force initial pressure F1 approx. N	Spring force final pressure F2 approx. N	Order No. screw-in washer
K0343.11903	K0343.12903	3	M6x0,75	14	31,5	17	11	3,5	- / 10	0,8	4,5	10	K0344.99
K0343.11004	K0343.12004	4	M8x1	18	38,5	21	13,5	4	- / 13	1,3	6	12	K0344.90
K0343.11105	K0343.12105	5	M10x1	21	43,5	24	14,5	5	- / 17	1,3	5	12	K0344.91
K0343.11206	K0343.12206	6	M12x1,5	25	51,7	28	17,7	6	- / 19	1,8	6	14	K0344.92
K0343.11308	K0343.12308	8	M16x1,5	33	68	36	24	8	- / 24	2,3	15	35	K0344.93
K0343.11410	K0343.12410	10	M20x1,5	33	74	40	24	10	- / 30	2,8	15	34	K0344.94
K0343.11412	K0343.12412	12	M20x1,5	33	78	42	24	12	- / 30	2,8	15	39	K0344.94
K0343.11516	K0343.12516	16	M24x2	40	96	50	30	16	- / 36	3,2	20	46	K0344.95

Indexing plungers

without collar with extended indexing pin



Material:

Steel version:
Indexing pin hardened:
grade 5.8.

Stainless steel version,
Indexing pin hardened
Threaded sleeve 1.4305
Indexing pin 1.4034

Indexing pin not hardened
Threaded sleeve 1.4305
Indexing pin 1.4305

Mushroom knob black grey thermoplastic

Version:

Steel version:
Indexing pin hardened, ground, black oxidised.

Stainless steel version:
Indexing pin hardened, ground and bright.
Indexing pin not hardened, ground and bright.

Sample order:

K0633.21004

Note:

Indexing plungers are used to prevent any change in locking position due to lateral forces. A new locking position can only be set after the pin has been manually disengaged.

A washer is available to aid by screwing in the indexing plungers. The washer slides beneath the mushroom knob so that the carrier pins engage in the slot.

On request:

Special versions.

Accessories:

Spacer rings K0665

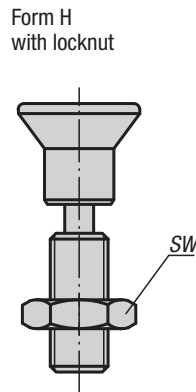
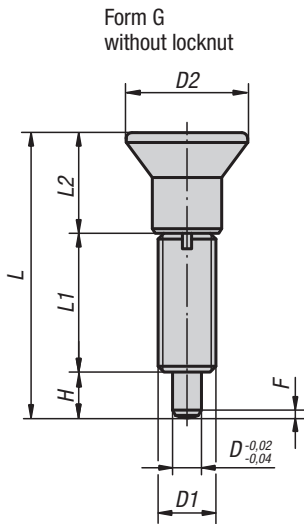
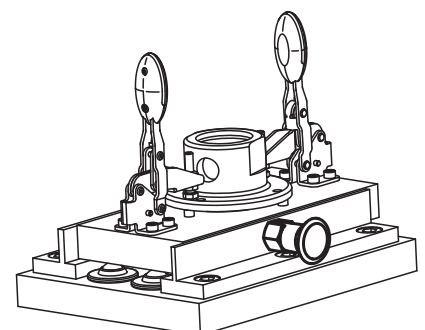

with screw-in washer

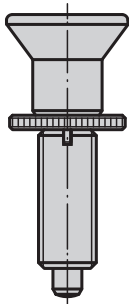

screw-in washer

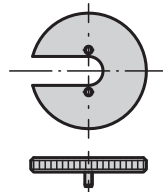

Indexing plungers

without collar with extended indexing pin

KIPP Indexing plungers without collar with extended indexing pin, steel, indexing pin hardened

Order No. Form G	Order No. Form H	D	D1	D2	L	L1	L2	H	SW	F x 30°	Spring force initial pressure F1 approx. N	Spring force final pressure F2 approx. N	Order No. screw-in washer
K0633.21903	K0633.22903	3	M6x0,75	14	33	17	11	5	- / 10	0,8	4,5	12	K0344.99
K0633.21004	K0633.22004	4	M8x1	18	40,5	21	13,5	6	- / 13	1	6	15	K0344.90
K0633.21105	K0633.22105	5	M10x1	21	46,5	24	14,5	8	- / 17	1,3	5	16	K0344.91
K0633.21206	K0633.22206	6	M12x1,5	25	54,7	28	17,7	9	- / 19	1,8	6	18	K0344.92
K0633.21308	K0633.22308	8	M16x1,5	33	72	36	24	12	- / 24	2,3	15	45	K0344.93
K0633.21410	K0633.22410	10	M20x1,5	33	79	40	24	15	- / 30	2,8	15	43	K0344.94
K0633.21412	K0633.22412	12	M20x1,5	33	84	42	24	18	- / 30	2,8	15	51	K0344.94
K0633.21516	K0633.22516	16	M24x2	40	104	50	30	24	- / 36	3,2	20	60	K0344.95

KIPP Indexing plungers without collar with extended indexing pin, stainless steel, indexing pin hardened

Order No. Form G	Order No. Form H	D	D1	D2	L	L1	L2	H	SW	F x 30°	Spring force initial pressure F1 approx. N	Spring force final pressure F2 approx. N	Order No. screw-in washer
K0633.201903	K0633.202903	3	M6x0,75	14	33	17	11	5	- / 10	0,8	4,5	12	K0344.99
K0633.201004	K0633.202004	4	M8x1	18	40,5	21	13,5	6	- / 13	1	6	15	K0344.90
K0633.201105	K0633.202105	5	M10x1	21	46,5	24	14,5	8	- / 17	1,3	5	16	K0344.91
K0633.201206	K0633.202206	6	M12x1,5	25	54,7	28	17,7	9	- / 19	1,8	6	18	K0344.92
K0633.201308	K0633.202308	8	M16x1,5	33	72	36	24	12	- / 24	2,3	15	45	K0344.93
K0633.201410	K0633.202410	10	M20x1,5	33	79	40	24	15	- / 30	2,8	15	43	K0344.94
K0633.201412	K0633.202412	12	M20x1,5	33	84	42	24	18	- / 30	2,8	15	51	K0344.94
K0633.201516	K0633.202516	16	M24x2	40	104	50	30	24	- / 36	3,2	20	60	K0344.95

KIPP Indexing plungers without collar with extended indexing pin, stainless steel, indexing pin not hardened

Order No. Form G	Order No. Form H	D	D1	D2	L	L1	L2	H	SW	F x 30°	Spring force initial pressure F1 approx. N	Spring force final pressure F2 approx. N	Order No. screw-in washer
K0633.211903	K0633.212903	3	M6x0,75	14	33	17	11	5	- / 10	0,8	4,5	12	K0344.99
K0633.211004	K0633.212004	4	M8x1	18	40,5	21	13,5	6	- / 13	1	6	15	K0344.90
K0633.211105	K0633.212105	5	M10x1	21	46,5	24	14,5	8	- / 17	1,3	5	16	K0344.91
K0633.211206	K0633.212206	6	M12x1,5	25	54,7	28	17,7	9	- / 19	1,8	6	18	K0344.92
K0633.211308	K0633.212308	8	M16x1,5	33	72	36	24	12	- / 24	2,3	15	45	K0344.93
K0633.211410	K0633.212410	10	M20x1,5	33	79	40	24	15	- / 30	2,8	15	43	K0344.94
K0633.211412	K0633.212412	12	M20x1,5	33	84	42	24	18	- / 30	2,8	15	51	K0344.94
K0633.211516	K0633.212516	16	M24x2	40	104	50	30	24	- / 36	3,2	20	60	K0344.95

Indexing plungers

stainless steel without collar



Form G
without locknut

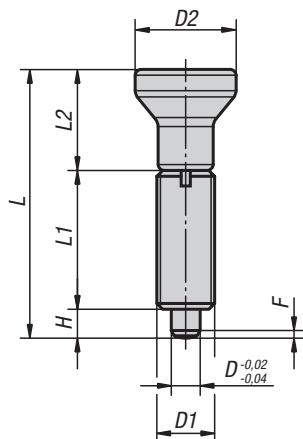

with screw-in washer

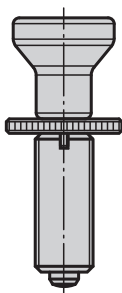

Form H
with locknut

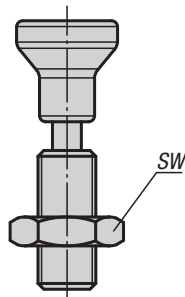

screw-in washer

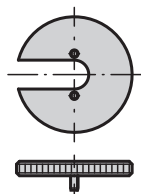

Material:

Indexing pin hardened:
Threaded sleeve 1.4305.
Indexing pin 1.4034.

Indexing pin not hardened:
Threaded sleeve 1.4305.
Indexing pin 1.4305.

Mushroom knob 1.4305, electrolytic-polish.

Version:

Bright.
Indexing pin ground.

Sample order:

K0634.001004

Note:

Indexing plungers are used to prevent any change in locking position due to lateral forces. A new locking position can only be set after the pin has been manually disengaged. A screw-in washer can be supplied to help screw in the indexing plungers. The washer is slid beneath the disengaged mushroom knob so that the follower pins engage in the slot.

On request:

Special versions.

Accessories:

Spacer rings K0665

KIPP Indexing plungers stainless steel without collar, indexing pin hardened

Order No. Form G	Order No. Form H	D	D1	D2	L	L1	L2	H	SW	F x 30°	Spring force initial pressure F1 approx. N	Spring force final pressure F2 approx. N	Order No. screw-in washer
K0634.001903	K0634.002903	3	M6x0,75	14	34,5	17	14	3,5	- / 10	0,8	4,5	10	K0344.99
K0634.001004	K0634.002004	4	M8x1	18	43	21	18	4	- / 13	1	6	12	K0344.90
K0634.001105	K0634.002105	5	M10x1	21	50	24	21	5	- / 17	1,3	5	12	K0344.91
K0634.001206	K0634.002206	6	M12x1,5	25	59	28	25	6	- / 19	1,8	6	14	K0344.92
K0634.001308	K0634.002308	8	M16x1,5	33	77	36	33	8	- / 24	2,3	15	35	K0344.93
K0634.001410	K0634.002410	10	M20x1,5	33	83	40	33	10	- / 30	2,8	15	34	K0344.94
K0634.001412	K0634.002412	12	M20x1,5	33	87	42	33	12	- / 30	2,8	15	39	K0344.94
K0634.001516	K0634.002516	16	M24x2	40	106	50	40	16	- / 36	3,2	20	46	K0344.95

KIPP Indexing plungers stainless steel without collar, indexing pin not hardened

Order No. Form G	Order No. Form H	D	D1	D2	L	L1	L2	H	SW	F x 30°	Spring force initial pressure F1 approx. N	Spring force final pressure F2 approx. N	Order No. screw-in washer
K0634.111903	K0634.112903	3	M6x0,75	14	34,5	17	14	3,5	- / 10	0,8	4,5	10	K0344.99
K0634.111004	K0634.112004	4	M8x1	18	43	21	18	4	- / 13	1	6	12	K0344.90
K0634.111105	K0634.112105	5	M10x1	21	50	24	21	5	- / 17	1,3	5	12	K0344.91
K0634.111206	K0634.112206	6	M12x1,5	25	59	28	25	6	- / 19	1,8	6	14	K0344.92
K0634.111308	K0634.112308	8	M16x1,5	33	77	36	33	8	- / 24	2,3	15	35	K0344.93
K0634.111410	K0634.112410	10	M20x1,5	33	83	40	33	10	- / 30	2,8	15	34	K0344.94
K0634.111412	K0634.112412	12	M20x1,5	33	87	42	33	12	- / 30	2,8	15	39	K0344.94
K0634.111516	K0634.112516	16	M24x2	40	106	50	40	16	- / 36	3,2	20	46	K0344.95

Notes

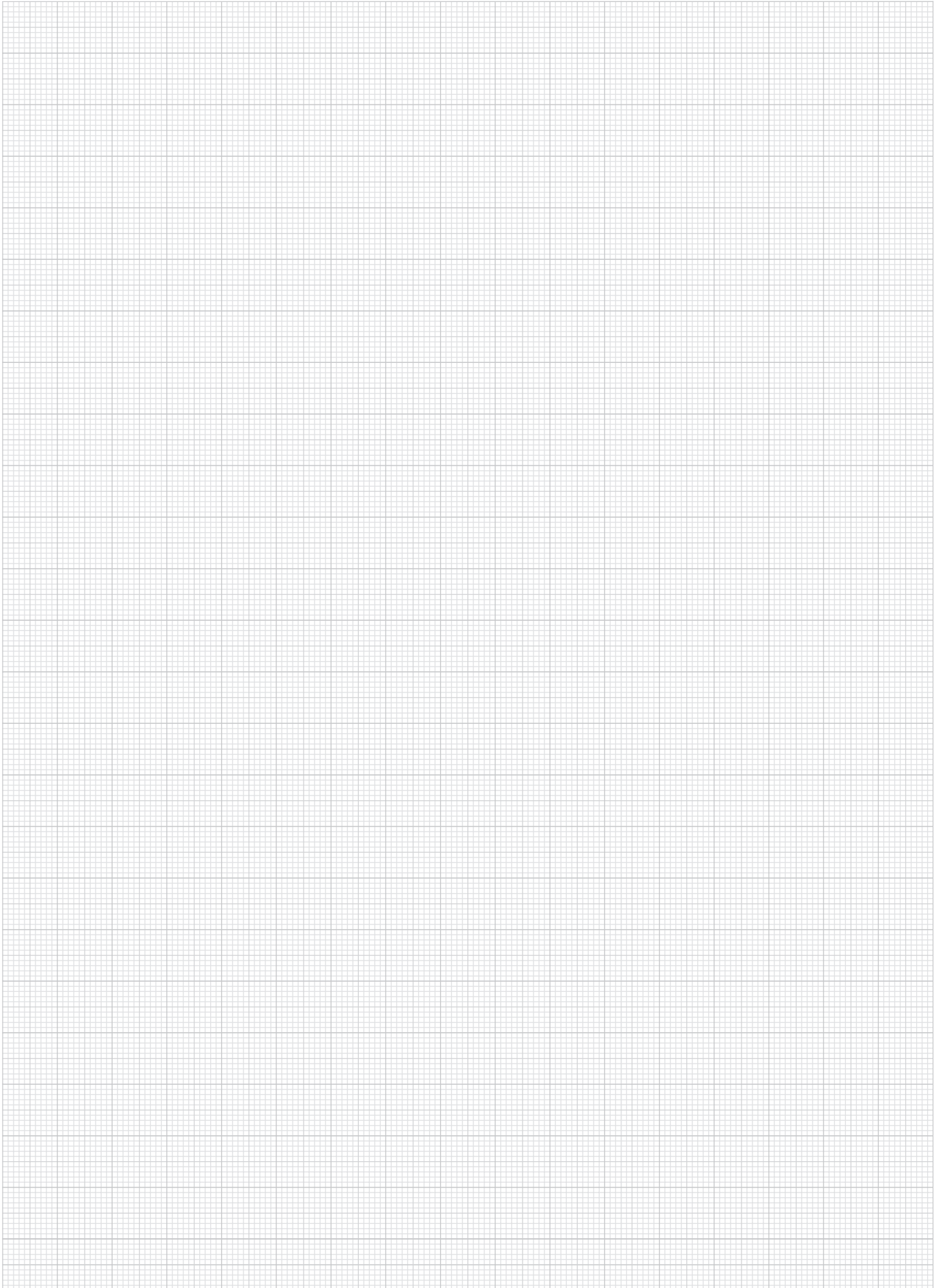

Indexing plungers

without collar



Form G
without locknut

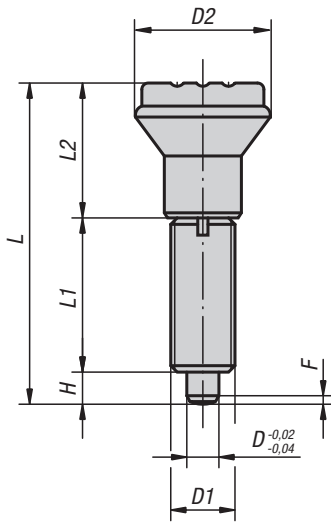

Form H
with locknut

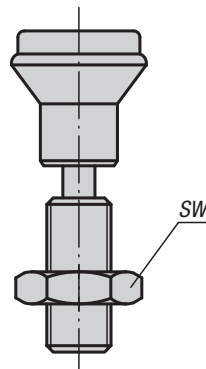

with screw-in washer

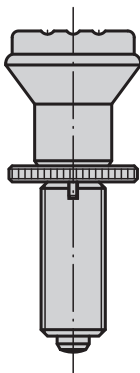

screw-in washer

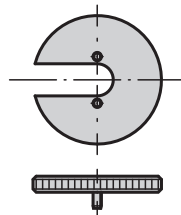

Material:

Steel version:
Indexing pin hardened:
grade 5.8.

Stainless steel version,
Indexing pin hardened
Threaded sleeve 1.4305
Indexing pin 1.4034

Indexing pin not hardened
Threaded sleeve 1.4305
Indexing pin 1.4305

Mushroom knob black grey thermoplastic

Version:

Steel version:
Indexing pin hardened, ground, black oxidised.

Stainless steel version:
Indexing pin hardened, ground and bright.
Indexing pin not hardened, ground and bright.

Sample order:

K0344.02206

Note:

Indexing plungers are used to prevent any change in locking position due to lateral forces. A new locking position can only be set after the pin has been manually disengaged.

A screw-in washer can be supplied to help screw in the indexing plungers. The washer is slid beneath the disengaged mushroom knob so that the carrier pins engage in the slot.

On request:

Special versions.

Accessories:

Spacer rings K0665

Indexing plungers

without collar



KIPP Indexing plungers without collar, steel, indexing pin hardened

Order No. Form G	Order No. Form H	D	D1	D2	L	L1	L2	H	SW	F x 30°	Spring force initial pressure F1 approx. N	Spring force final pressure F2 approx. N	Order No. screw-in washer
K0344.1105	K0344.2105	5	M10x1	21	47	24	18	5	-/17	1,3	5	12	K0344.91
K0344.1206	K0344.2206	6	M12x1,5	25	56	28	22	6	-/19	1,8	6	14	K0344.92
K0344.1308	K0344.2308	8	M16x1,5	33	74	36	30	8	-/24	2,3	15	35	K0344.93
K0344.1410	K0344.2410	10	M20x1,5	33	80	40	30	10	-/30	2,8	15	34	K0344.94

KIPP Indexing plungers without collar, stainless steel, indexing pin hardened

Order No. Form G	Order No. Form H	D	D1	D2	L	L1	L2	H	SW	F x 30°	Spring force initial pressure F1 approx. N	Spring force final pressure F2 approx. N	Order No. screw-in washer
K0344.01105	K0344.02105	5	M10x1	21	47	24	18	5	-/17	1,3	5	12	K0344.91
K0344.01206	K0344.02206	6	M12x1,5	25	56	28	22	6	-/19	1,8	6	14	K0344.92
K0344.01308	K0344.02308	8	M16x1,5	33	74	36	30	8	-/24	2,3	15	35	K0344.93
K0344.01410	K0344.02410	10	M20x1,5	33	80	40	30	10	-/30	2,8	15	34	K0344.94

KIPP Indexing plungers without collar, stainless steel, indexing pin not hardened

Order No. Form G	Order No. Form H	D	D1	D2	L	L1	L2	H	SW	F x 30°	Spring force initial pressure F1 approx. N	Spring force final pressure F2 approx. N	Order No. screw-in washer
K0344.11105	K0344.12105	5	M10x1	21	47	24	18	5	-/17	1,3	5	12	K0344.91
K0344.11206	K0344.12206	6	M12x1,5	25	56	28	22	6	-/19	1,8	6	14	K0344.92
K0344.11308	K0344.12308	8	M16x1,5	33	74	36	30	8	-/24	2,3	15	35	K0344.93
K0344.11410	K0344.12410	10	M20x1,5	33	80	40	30	10	-/30	2,8	15	34	K0344.94

Indexing plungers

without collar



Material:

Steel version:
Indexing pin hardened:
grade 5.8.

Stainless steel version:
Indexing pin hardened:
Threaded sleeve 1.4305.
Indexing pin 1.4034.

Indexing pin not hardened:
Threaded sleeve 1.4305.
Indexing pin 1.4305.

Version:

Steel version:
Indexing pin hardened, ground, black oxidised.

Stainless steel version:
Indexing pin hardened, ground and bright.
Indexing pin not hardened, ground and bright.

Sample order:

K0345.01206

Note:

Indexing plungers are used to prevent any change in locking position due to lateral forces. A new locking position can only be set after the pin has been disengaged.

Special grips can be fitted on the projecting threaded pin. This pin is also suitable for automatic actuation by e.g. program controlled pneumatic cylinder or by remote control using bowden cables.

A washer is available to aid screwing in the indexing plungers. The washer is placed on the threaded sleeve so that the carrier pins engage in the slot.

On request:

Special versions.

Accessories:

Spacer rings K0665

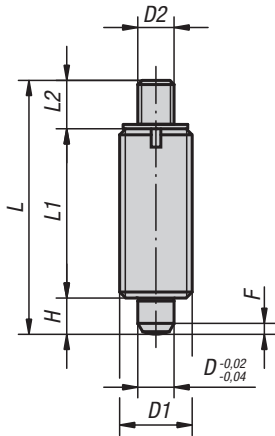

Form J
with threaded pin
without locknut

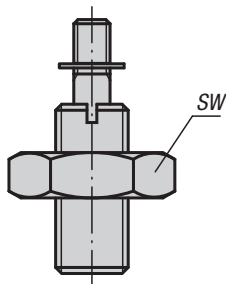

Form K
with threaded pin
with locknut

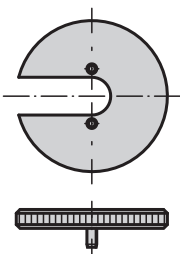

screw-in washer

Indexing plungers

without collar



KIPP Indexing plungers without collar, steel, indexing pin hardened

Order No. Form J	Order No. Form K	D	D1	D2	L	L1	L2	H	SW	F x 30°	Spring force initial pressure F1 approx. N	Spring force final pressure F2 approx. N	Order No. screw-in washer
K0345.1903	K0345.2903	3	M6x0,75	M2	24	17	3,5	3,5	- / 10	0,8	4,5	10	K0344.99
K0345.1004	K0345.2004	4	M8x1	M3	32	21	7	4	- / 13	1	6	12	K0344.90
K0345.1105	K0345.2105	5	M10x1	M4	37	24	8	5	- / 17	1,3	5	12	K0344.91
K0345.1206	K0345.2206	6	M12x1,5	M6	42	28	8	6	- / 19	1,8	6	14	K0344.92
K0345.1308	K0345.2308	8	M16x1,5	M8	56	36	12	8	- / 24	2,3	15	35	K0344.93
K0345.1410	K0345.2410	10	M20x1,5	M8	62	40	12	10	- / 30	2,8	15	34	K0344.94
K0345.1412	K0345.2412	12	M20x1,5	M8	66	42	12	12	- / 30	2,8	15	39	K0344.94
K0345.1516	K0345.2516	16	M24x2	M10	80	50	14	16	- / 36	3,2	20	46	K0344.95

KIPP Indexing plungers without collar, stainless steel, indexing pin hardened

Order No. Form J	Order No. Form K	D	D1	D2	L	L1	L2	H	SW	F x 30°	Spring force initial pressure F1 approx. N	Spring force final pressure F2 approx. N	Order No. screw-in washer
K0345.01903	K0345.02903	3	M6x0,75	M2	24	17	3,5	3,5	- / 10	0,8	4,5	10	K0344.99
K0345.01004	K0345.02004	4	M8x1	M3	32	21	7	4	- / 13	1	6	12	K0344.90
K0345.01105	K0345.02105	5	M10x1	M4	37	24	8	5	- / 17	1,3	5	12	K0344.91
K0345.01206	K0345.02206	6	M12x1,5	M6	42	28	8	6	- / 19	1,8	6	14	K0344.92
K0345.01308	K0345.02308	8	M16x1,5	M8	56	36	12	8	- / 24	2,3	15	35	K0344.93
K0345.01410	K0345.02410	10	M20x1,5	M8	62	40	12	10	- / 30	2,8	15	34	K0344.94
K0345.01412	K0345.02412	12	M20x1,5	M8	66	42	12	12	- / 30	2,8	15	39	K0344.94
K0345.01516	K0345.02516	16	M24x2	M10	80	50	14	16	- / 36	3,2	20	46	K0344.95

KIPP Indexing plungers without collar, stainless steel, indexing pin not hardened

Order No. Form J	Order No. Form K	D	D1	D2	L	L1	L2	H	SW	F x 30°	Spring force initial pressure F1 approx. N	Spring force final pressure F2 approx. N	Order No. screw-in washer
K0345.11903	K0345.12903	3	M6x0,75	M2	24	17	3,5	3,5	- / 10	0,8	4,5	10	K0344.99
K0345.11004	K0345.12004	4	M8x1	M3	32	21	7	4	- / 13	1	6	12	K0344.90
K0345.11105	K0345.12105	5	M10x1	M4	37	24	8	5	- / 17	1,3	5	12	K0344.91
K0345.11206	K0345.12206	6	M12x1,5	M6	42	28	8	6	- / 19	1,8	6	14	K0344.92
K0345.11308	K0345.12308	8	M16x1,5	M8	56	36	12	8	- / 24	2,3	15	35	K0344.93
K0345.11410	K0345.12410	10	M20x1,5	M8	62	40	12	10	- / 30	2,8	15	34	K0344.94
K0345.11412	K0345.12412	12	M20x1,5	M8	66	42	12	12	- / 30	2,8	15	39	K0344.94
K0345.11516	K0345.12516	16	M24x2	M10	80	50	14	16	- / 36	3,2	20	46	K0344.95

Indexing plungers

without collar



Material:

Steel version:
Indexing pin hardened:
grade 5.8.

Stainless steel version:
Indexing pin hardened:
Threaded sleeve 1.4305
Indexing pin 1.4034

Indexing pin not hardened
Threaded sleeve 1.4305
Indexing pin 1.4305

Key ring 1.4310, bright.

Version:

Steel version:
Indexing pin hardened, ground, black oxidised.

Stainless steel version:
Indexing pin hardened, ground and bright.
Indexing pin not hardened, ground and bright.

Sample order:

K0635.03206

Note:

Indexing plungers are used to prevent any change in locking position due to lateral forces. A new locking position can only be set after the pin has been disengaged.

The key ring is also suitable for actuation of the indexing plungers e.g. automatically (program-controlled) with the aid of a pneumatic cylinder or remote control with bowden cables.

A screw-in washer can be supplied to help screw in the indexing plungers. The washer is fitted onto the threaded sleeve so that the carrier pins engage in the slot.

On request:

Special versions.

Accessories:

Spacer rings K0665

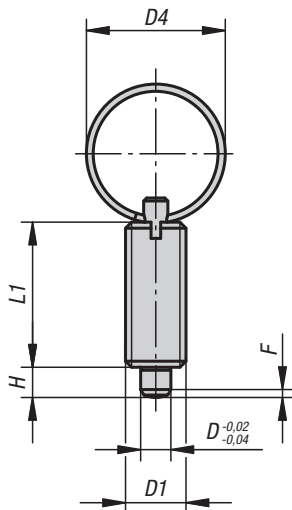

Form T
without locknut

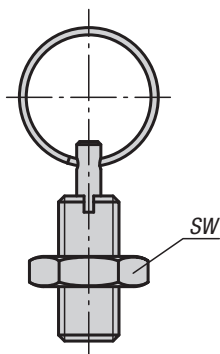

Form U
with locknut

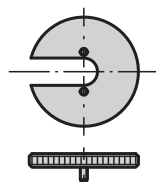

screw-in washer

Indexing plungers

without collar



KIPP Indexing plungers without collar, steel, indexing pin hardened

Order No. Form T	Order No. Form U	D	D1	D4	L1	H	SW	F x 30°	Spring force initial pressure F1 approx. N	Spring force final pressure F2 approx. N	Order No. screw-in washer
K0635.3004	K0635.4004	4	M8x1	15	21	4	-/13	1	6	12	K0344.90
K0635.3105	K0635.4105	5	M10x1	23	24	5	-/17	1,3	5	12	K0344.91
K0635.3206	K0635.4206	6	M12x1,5	23	28	6	-/19	1,8	6	14	K0344.92
K0635.3308	K0635.4308	8	M16x1,5	28	36	8	-/24	2,3	15	35	K0344.93
K0635.3410	K0635.4410	10	M20x1,5	28	40	10	-/30	2,8	15	34	K0344.94

KIPP Indexing plungers without collar, stainless steel, indexing pin hardened

Order No. Form T	Order No. Form U	D	D1	D4	L1	H	SW	F x 30°	Spring force initial pressure F1 approx. N	Spring force final pressure F2 approx. N	Order No. screw-in washer
K0635.03004	K0635.04004	4	M8x1	15	21	4	-/13	1	6	12	K0344.90
K0635.03105	K0635.04105	5	M10x1	23	24	5	-/17	1,3	5	12	K0344.91
K0635.03206	K0635.04206	6	M12x1,5	23	28	6	-/19	1,8	6	14	K0344.92
K0635.03308	K0635.04308	8	M16x1,5	28	36	8	-/24	2,3	15	35	K0344.93
K0635.03410	K0635.04410	10	M20x1,5	28	40	10	-/30	2,8	15	34	K0344.94

KIPP Indexing plungers without collar, stainless steel, indexing pin not hardened

Order No. Form T	Order No. Form U	D	D1	D4	L1	H	SW	F x 30°	Spring force initial pressure F1 approx. N	Spring force final pressure F2 approx. N	Order No. screw-in washer
K0635.13004	K0635.14004	4	M8x1	15	21	4	-/13	1	6	12	K0344.90
K0635.13105	K0635.14105	5	M10x1	23	24	5	-/17	1,3	5	12	K0344.91
K0635.13206	K0635.14206	6	M12x1,5	23	28	6	-/19	1,8	6	14	K0344.92
K0635.13308	K0635.14308	8	M16x1,5	28	36	8	-/24	2,3	15	35	K0344.93
K0635.13410	K0635.14410	10	M20x1,5	28	40	10	-/30	2,8	15	34	K0344.94

Indexing plungers

without collar

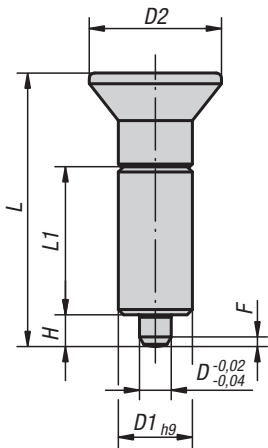

Form L
without locking slot

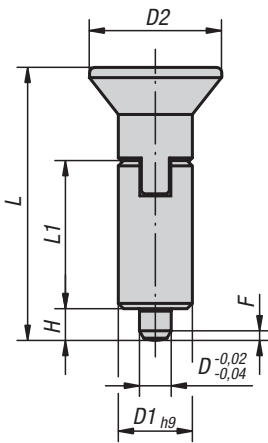

Form M
with locking slot

Material:

Steel version:
Indexing pin hardened:
Sleeve 1.0403 weldable.
Indexing pin grade 5.8

Stainless steel version:
Indexing pin hardened
Sleeve 1.4301 weldable.
Indexing pin 1.4034.

Indexing pin not hardened:
Sleeve 1.4301 weldable.
Indexing pin 1.4305.

Mushroom knob black grey thermoplastic.

Version:

Steel version:
Indexing pin hardened, ground, black oxidised.

Stainless steel version:
Indexing pin hardened, ground and bright.
Indexing pin not hardened, ground and bright.

Sample order:

K0346.01206

Note:

Indexing plungers are used to prevent any change in locking position due to lateral forces. A new locking position can only be set after the pin has been manually disengaged.

Form M is recommended for applications in where the indexing plungers should remain disengaged over extended periods and the pin prevented from springing back.

To weld the indexing plungers we recommend inert gas-shielded welding with TIG welding equipment.

On request:

Special versions.

Indexing plungers

without collar



KIPP Indexing plungers without collar, steel, indexing pin hardened

Order No. Form L	Order No. Form M	D	D1	D2	L	L1	H	F x 30°	Spring force initial pressure F1 approx. N	Spring force final pressure F2 approx. N
K0346.1004	K0346.2004	4	10	18	38,5	21	4	1	6	12
K0346.1105	K0346.2105	5	12	21	43,5	24	5	1,3	5	12
K0346.1206	K0346.2206	6	14	25	51,7	28	6	1,8	6	14
K0346.1308	K0346.2308	8	18	33	68	36	8	2,3	15	35
K0346.1410	K0346.2410	10	22	33	74	40	10	2,8	15	34

KIPP Indexing plungers without collar, stainless steel, indexing pin hardened

Order No. Form L	Order No. Form M	D	D1	D2	L	L1	H	F x 30°	Spring force initial pressure F1 approx. N	Spring force final pressure F2 approx. N
K0346.01004	K0346.02004	4	10	18	38,5	21	4	1	6	12
K0346.01105	K0346.02105	5	12	21	43,5	24	5	1,3	5	12
K0346.01206	K0346.02206	6	14	25	51,7	28	6	1,8	6	14
K0346.01308	K0346.02308	8	18	33	68	36	8	2,3	15	35
K0346.01410	K0346.02410	10	22	33	74	40	10	2,8	15	34

KIPP Indexing plungers without collar, stainless steel, indexing pin not hardened

Order No. Form L	Order No. Form M	D	D1	D2	L	L1	H	F x 30°	Spring force initial pressure F1 approx. N	Spring force final pressure F2 approx. N
K0346.11004	K0346.12004	4	10	18	38,5	21	4	1	6	12
K0346.11105	K0346.12105	5	12	21	43,5	24	5	1,3	5	12
K0346.11206	K0346.12206	6	14	25	51,7	28	6	1,8	6	14
K0346.11308	K0346.12308	8	18	33	68	36	8	2,3	15	35
K0346.11410	K0346.12410	10	22	33	74	40	10	2,8	15	34

Indexing plungers

without collar

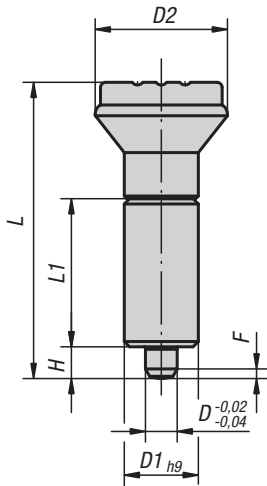

Form L
without locking slot

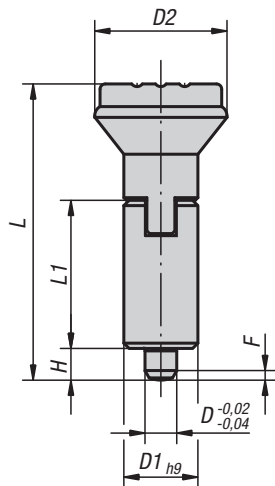

Form M
with locking slot

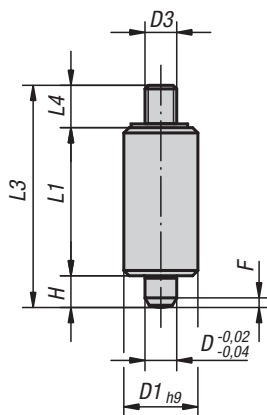

Form N
with threaded pin

Material:

Steel version:
Indexing pin hardened:
Sleeve 1.0403 weldable.
Indexing pin grade 5.8.

Stainless steel version:
Indexing pin hardened:
Sleeve 1.4301 weldable.
Indexing pin 1.4034.

Indexing pin not hardened:
Sleeve 1.4301 weldable.
Indexing pin 1.4305.

Mushroom knob black grey thermoplastic.

Version:

Steel version:
Indexing pin hardened, ground, black oxidised.

Stainless steel version:
Indexing pin hardened, ground and bright.
Indexing pin not hardened, ground and bright.

Sample order:

K0347.02206

Note:

Indexing plungers are used to prevent any change in locking position due to lateral forces. A new locking position can only be set after the pin has been manually disengaged.

Form M is recommended for applications where the indexing plungers should remain disengaged over an extended period and the pin prevented from springing back.

Special grips can be fitted on the projecting threaded pin of Form N. This pin is also suitable for actuation of the locking bolt e.g. automatically (program-controlled) with the aid of a pneumatic cylinder or remote controlled with bowden cables.

To weld the indexing plungers we recommend inert gas shielded welding with TIG welding equipment.

On request:

Special versions.

Indexing plungers

without collar



KIPP Indexing plungers without collar, steel, indexing pin hardened

Order No. Form L	Order No. Form M	Order No. Form N	D	D1	D2	D3	L	L1	L3	L4	H	F x 30°	Spring force initial pressure F1 approx. N	Spring force final pressure F2 approx. N
K0347.1105	K0347.2105	K0347.3105	5	12	21/21/-	-/-M4	47/47/-	24	-/-/37	-/-/8	5	1,3	5	12
K0347.1206	K0347.2206	K0347.3206	6	14	25/25/-	-/-M6	56/56/-	28	-/-/43	-/-/9	6	1,8	6	14
K0347.1308	K0347.2308	K0347.3308	8	18	33/33/-	-/-M8	74/74/-	36	-/-/56	-/-/12	8	2,3	15	35
K0347.1410	K0347.2410	K0347.3410	10	22	33/33/-	-/-M8	80/80/-	40	-/-/62	-/-/12	10	2,8	15	34



KIPP Indexing plungers without collar, stainless steel, indexing pin hardened

Order No. Form L	Order No. Form M	Order No. Form N	D	D1	D2	D3	L	L1	L3	L4	H	F x 30°	Spring force initial pressure F1 approx. N	Spring force final pressure F2 approx. N
K0347.01105	K0347.02105	K0347.03105	5	12	21/21/-	-/-M4	47/47/-	24	-/-/37	-/-/8	5	1,3	5	12
K0347.01206	K0347.02206	K0347.03206	6	14	25/25/-	-/-M6	56/56/-	28	-/-/43	-/-/9	6	1,8	6	14
K0347.01308	K0347.02308	K0347.03308	8	18	33/33/-	-/-M8	74/74/-	36	-/-/56	-/-/12	8	2,3	15	35
K0347.01410	K0347.02410	K0347.03410	10	22	33/33/-	-/-M8	80/80/-	40	-/-/62	-/-/12	10	2,8	15	34

KIPP Indexing plungers without collar, stainless steel, indexing pin not hardened

Order No. Form L	Order No. Form M	Order No. Form N	D	D1	D2	D3	L	L1	L3	L4	H	F x 30°	Spring force initial pressure F1 approx. N	Spring force final pressure F2 approx. N
K0347.11105	K0347.12105	K0347.13105	5	12	21/21/-	-/-M4	47/47/-	24	-/-/37	-/-/8	5	1,3	5	12
K0347.11206	K0347.12206	K0347.13206	6	14	25/25/-	-/-M6	56/56/-	28	-/-/43	-/-/9	6	1,8	6	14
K0347.11308	K0347.12308	K0347.13308	8	18	33/33/-	-/-M8	74/74/-	36	-/-/56	-/-/12	8	2,3	15	35
K0347.11410	K0347.12410	K0347.13410	10	22	33/33/-	-/-M8	80/80/-	40	-/-/62	-/-/12	10	2,8	15	34

Indexing plungers

without collar

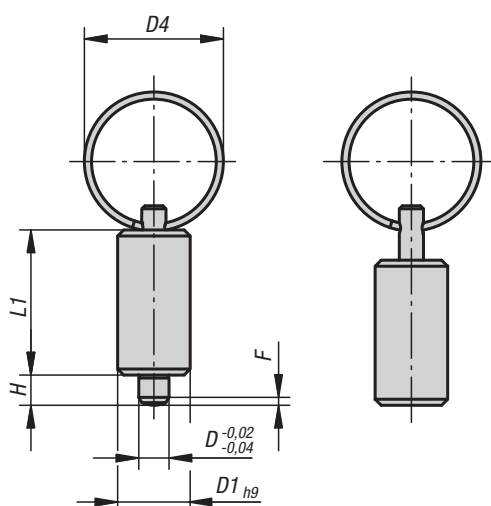

Form V
with key ring

Material:

Steel version:
Indexing pin hardened.
Sleeve 1.0403 weldable.
Indexing pin grade 5.8.

Stainless steel version:
Indexing pin hardened.
Sleeve 1.4301 weldable.
Indexing pin 1.4034.

Indexing pin not hardened:
Sleeve 1.4301 weldable.
Indexing pin 1.4305.

Key ring 1.4310, bright.

Version:

Steel version:
Indexing pin hardened, ground, black oxidised.

Stainless steel version:
Indexing pin hardened, ground and bright.
Indexing pin not hardened, ground and bright.

Sample order:

K0636.4206

Note:

Indexing plungers are used to prevent any change in locking position due to lateral forces. A new locking position can only be set after the pin has been disengaged.

The key ring is also suitable for actuation of the indexing plungers e.g. automatically (programme-controlled) with the aid of a pneumatic cylinder or remote control actuation with bowden cables. To weld the indexing plungers we recommend inert gas-shielded welding with TIG welding equipment.

On request:

Special versions.

KIPP Indexing plungers without collar, steel, indexing pin hardened

Order No. Form V	D	D1	D4	L1	H	F x 30°	Spring force initial pressure F1 approx. N	Spring force final pressure F2 approx. N
K0636.4004	4	10	15	21	4	1	6	12
K0636.4105	5	12	23	24	5	1,3	5	12
K0636.4206	6	14	23	28	6	1,8	6	14
K0636.4308	8	18	28	36	8	2,3	15	35
K0636.4410	10	22	28	40	10	2,8	15	34

KIPP Indexing plungers without collar, stainless steel, indexing pin hardened

Order No. Form V	D	D1	D4	L1	H	F x 30°	Spring force initial pressure F1 approx. N	Spring force final pressure F2 approx. N
K0636.04004	4	10	15	21	4	1	6	12
K0636.04105	5	12	23	24	5	1,3	5	12
K0636.04206	6	14	23	28	6	1,8	6	14
K0636.04308	8	18	28	36	8	2,3	15	35
K0636.04410	10	22	28	40	10	2,8	15	34

KIPP Indexing plungers without collar, stainless steel, indexing pin not hardened

Order No. Form V	D	D1	D4	L1	H	F x 30°	Spring force initial pressure F1 approx. N	Spring force final pressure F2 approx. N
K0636.14004	4	10	15	21	4	1	6	12
K0636.14105	5	12	23	24	5	1,3	5	12
K0636.14206	6	14	23	28	6	1,8	6	14
K0636.14308	8	18	28	36	8	2,3	15	35
K0636.14410	10	22	28	40	10	2,8	15	34

Spacer rings

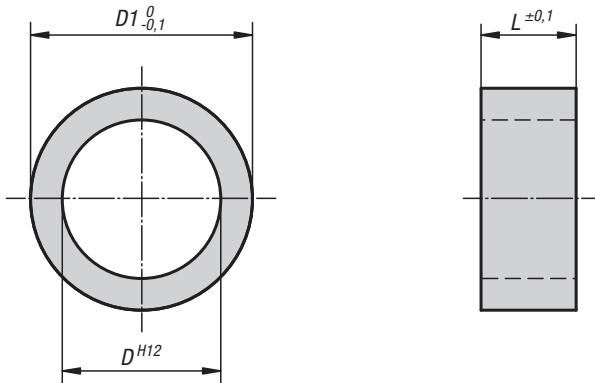

Material:
Stainless steel

Version:
Bright.

Sample order:
K0665.90811021

Note:
Spacer rings are used to adjust the indexing plunger thread length to suit the application wall thickness.

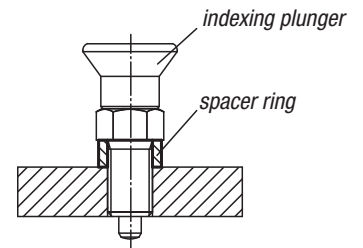

KIPP Spacer rings

Order No.	D	D1	L
K0665.90811021	8	11	2
K0665.90811031	8	11	3
K0665.90811041	8	11	4
K0665.90811061	8	11	6
K0665.90811081	8	11	8
K0665.91014021	10	14	2
K0665.91014031	10	14	3
K0665.91014041	10	14	4
K0665.91014061	10	14	6
K0665.91014081	10	14	8
K0665.91215021	12	15	2
K0665.91215041	12	15	4
K0665.91215051	12	15	5
K0665.91215061	12	15	6
K0665.91215081	12	15	8
K0665.91217021	12	17	2
K0665.91217041	12	17	4
K0665.91217051	12	17	5
K0665.91217061	12	17	6
K0665.91217081	12	17	8
K0665.91621041	16	21	4
K0665.91621051	16	21	5
K0665.91621061	16	21	6
K0665.91621081	16	21	8
K0665.91621101	16	21	10



Indexing plungers - Premium

with tapered pin

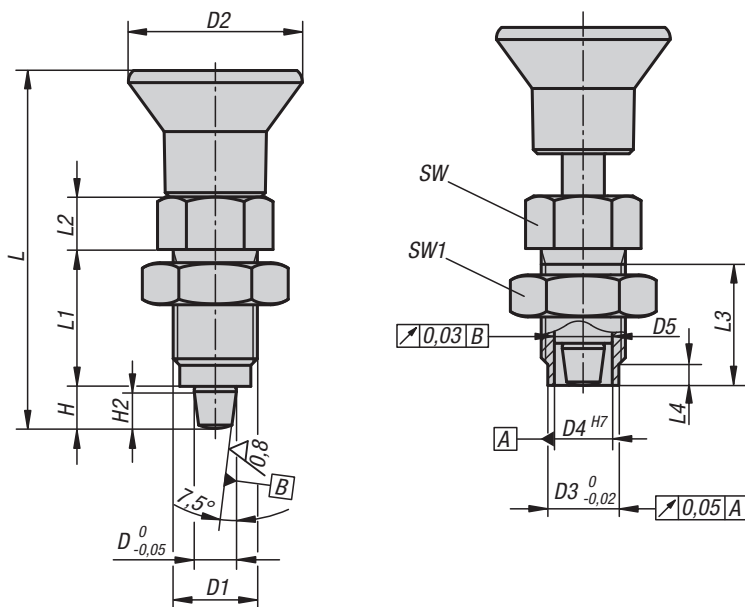

Material:

Steel version:
indexing pin hardened:
grade 5.8

Stainless steel version:
indexing pin hardened
threaded sleeve 1.4305
indexing pin 1.4034

Mushroom knob black grey thermoplastic.

Version:

Steel version:
indexing pin hardened, ground and black oxidised.

Stainless steel version:
indexing pin hardened, ground and bright.

Sample order:

K0736.52206

Note:

Premium indexing plungers are characterized by more stringent manufacturing requirements for the indexing plungers and the threaded sleeve. In addition, a centring locator that can be used to increase the positioning accuracy is provided on the threaded sleeve. These indexing plungers are used when it is necessary to prevent shifting of the locked position by transverse forces and greater positioning accuracy is required. A new locking position can only be set after the pin has been manually disengaged. When high lateral forces are to be expected, the centring locator should be used.

Assembly:

When using the threaded sleeve centring, it is recommended the receiving reamed hole be machined before tapping. The conical contact surface is aligned by the threaded sleeve and locking nut.

Accessories:

Matching tapered bush K0736.

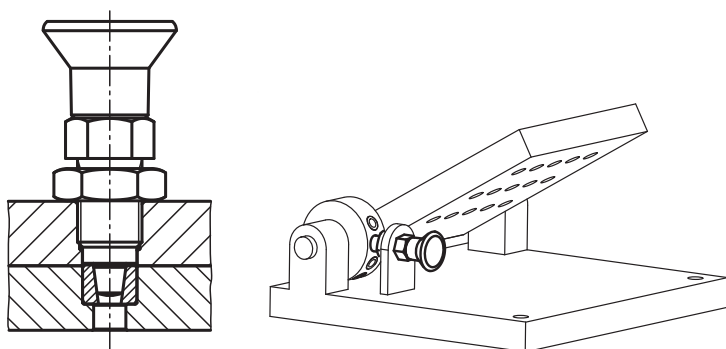

KIPP Premium indexing plungers with tapered pin, steel, indexing pin hardened

Order No.	Material	D	D1	D2	D3	D4	D5	L	L1	L2	L3	L4	H	H2	SW	SW1	Spring force initial pressure F1 approx. N	Spring force final pressure F2 approx. N
K0736.52105	Steel	5	M10x1	21	8	6	6 -0,01/-0,02	43,5	17	7	15	3	5	4	13	17	5	12
K0736.52206	Steel	6	M12x1,5	25	10	8,5	8,5 -0,01/-0,03	51,7	20	8	17	3	6	5	14	19	6	14
K0736.52308	Steel	8	M16x1,5	33	13,5	11	11 -0,01/-0,03	68	26	10	23	4	8	7	19	24	15	35
K0736.52410	Steel	10	M20x1,5	33	17	11	11 -0,01/-0,03	74	28	12	25	4	10	9	22	30	15	34

KIPP Premium indexing plungers with tapered pin, stainless steel, indexing pin hardened

Order No.	Material	D	D1	D2	D3	D4	D5	L	L1	L2	L3	L4	H	H2	SW	SW1	Spring force initial pressure F1 approx. N	Spring force final pressure F2 approx. N
K0736.502105	Stainless steel	5	M10x1	21	8	6	6 -0,01/-0,02	43,5	17	7	15	3	5	4	13	17	5	12
K0736.502206	Stainless steel	6	M12x1,5	25	10	8,5	8,5 -0,01/-0,03	51,7	20	8	17	3	6	5	14	19	6	14
K0736.502308	Stainless steel	8	M16x1,5	33	13,5	11	11 -0,01/-0,03	68	26	10	23	4	8	7	19	24	15	35
K0736.502410	Stainless steel	10	M20x1,5	33	17	11	11 -0,01/-0,03	74	28	12	25	4	10	9	22	30	15	34

Bushes tapered

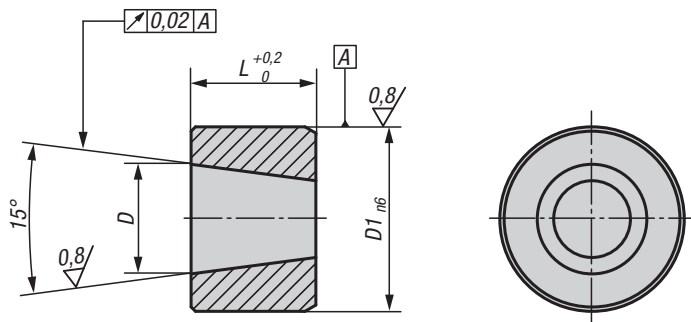
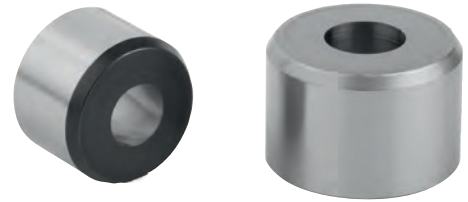
**Material:**

Steel or stainless steel 1.4034.

Version:

Steel version:

black oxidised, hardened and ground.

Stainless steel version:

bright, hardened and ground.

Sample order:

K0736.9106

Note:

Matching bushes for premium indexing plungers with tapered pin K0736.

Assembly:

To increase the coaxial alignment accuracy, the holes for the bush and the premium indexing plunger can be machined simultaneously.



KIPP Tapered bushes

Order No.	Material	D	D1	L
K0736.9105	Steel	5	8	6
K0736.9106	Steel	6	10	7
K0736.9108	Steel	8	13,5	9,5
K0736.9110	Steel	10	17	11,5
K0736.91005	Stainless steel	5	8	6
K0736.91006	Stainless steel	6	10	7
K0736.91008	Stainless steel	8	13,5	9,5
K0736.91010	Stainless steel	10	17	11,5

Indexing plungers - Premium

with cylindrical pin

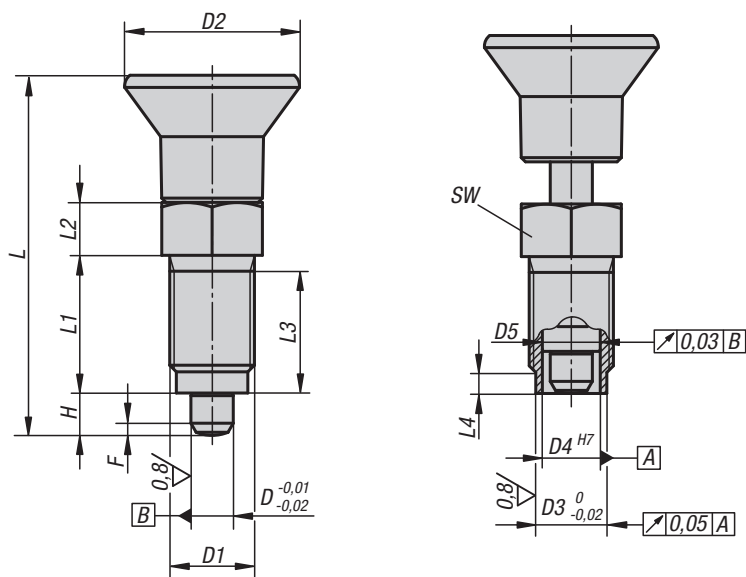

Material:

Steel version:
indexing pin hardened:
grade 5.8

Stainless steel version:
indexing pin hardened
threaded sleeve 1.4305
indexing pin 1.4034

Mushroom knob black grey thermoplastic.

Version:

Steel version:
indexing pin hardened, ground and black oxidised.

Stainless steel version:
indexing pin hardened, ground and bright.

Sample order:

K0736.41206

Note:

Premium indexing plungers are characterized by more stringent manufacturing requirements for the indexing plungers and threaded sleeve. In addition, a centring locator that can be used to increase the positioning accuracy is provided on the threaded sleeve. These indexing plungers are used when it is necessary to prevent shifting of the locked position by transverse forces and greater positioning accuracy is required. A new locking position can only be set after the pin has been manually disengaged. When high lateral forces are to be expected, the centring locator should be used.

Assembly:

When using the threaded sleeve centring, it is recommended the receiving reamed hole be machined before tapping.

On request:

Special versions and spacer rings.

Accessories:

Matching cylindrical bush K0736.
Locknut K0700....

Fixation
with bush:

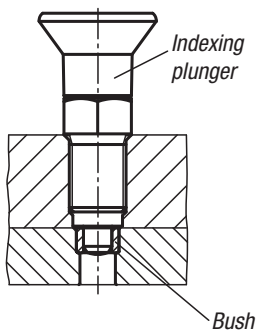

Fixation
without bush:

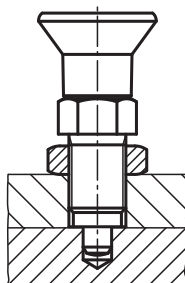

KIPP Premium indexing plungers with cylindrical pin, steel, indexing pin hardened

Order No.	Material	D	D1	D2	D3	D4	D5	L	L1	L2	L3	L4	H	SW	F x 30°	Spring force initial pressure F1 approx. N	Spring force final pressure F2 approx. N
K0736.41105	Steel	5	M10x1	21	8	6	6 -0,01/-0,02	43,5	17	7	15	3	5	13	1,3	5	12
K0736.41206	Steel	6	M12x1,5	25	10	8,5	8,5 -0,01/-0,03	51,7	20	8	17	3	6	14	1,8	6	14
K0736.41308	Steel	8	M16x1,5	33	13,5	11	11 -0,01/-0,03	68	26	10	23	4	8	19	2,3	15	35
K0736.41410	Steel	10	M20x1,5	33	17	11	11 -0,01/-0,03	74	28	12	25	4	10	22	2,8	15	34

KIPP Premium indexing plungers with cylindrical pin, stainless steel, indexing pin hardened

Order No.	Material	D	D1	D2	D3	D4	D5	L	L1	L2	L3	L4	H	SW	F x 30°	Spring force initial pressure F1 approx. N	Spring force final pressure F2 approx. N
K0736.401105	Stainless steel	5	M10x1	21	8	6	6 -0,01/-0,02	43,5	17	7	15	3	5	13	1,3	5	12
K0736.401206	Stainless steel	6	M12x1,5	25	10	8,5	8,5 -0,01/-0,03	51,7	20	8	17	3	6	14	1,8	6	14
K0736.401308	Stainless steel	8	M16x1,5	33	13,5	11	11 -0,01/-0,03	68	26	10	23	4	8	19	2,3	15	35
K0736.401410	Stainless steel	10	M20x1,5	33	17	11	11 -0,01/-0,03	74	28	12	25	4	10	22	2,8	15	34

Bushes cylindrical

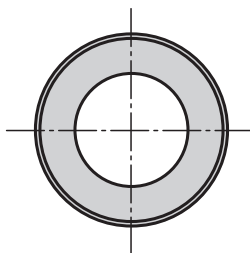
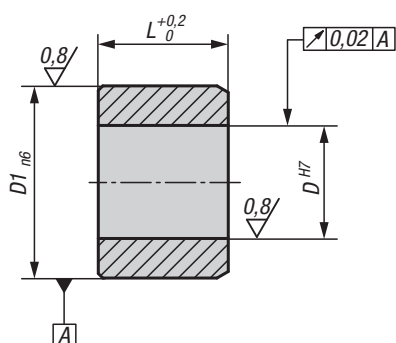
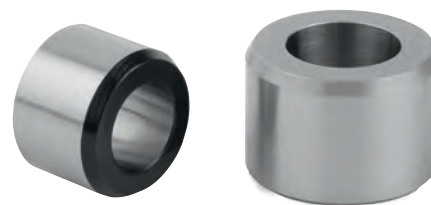
**Material:**

Steel or stainless steel 1.4034.

Version:

Steel version:
black oxidised, hardened and ground.
Stainless steel version:
bright, hardened and ground.

Sample order:

K0736.9005

Note:

Matching bushes for premium indexing plungers with cylindrical pin K0736.

Assembly:

To increase the coaxial alignment accuracy, the hole for the bush and the premium indexing plunger can be machined simultaneously.

KIPP Cylindrical bushes

Order No.	Material	D	D1	L
K0736.9005	Steel	5	8	6
K0736.9006	Steel	6	10	7
K0736.9008	Steel	8	13,5	9,5
K0736.9010	Steel	10	17	11,5
K0736.90005	Stainless steel	5	8	6
K0736.90006	Stainless steel	6	10	7
K0736.90008	Stainless steel	8	13,5	9,5
K0736.90010	Stainless steel	10	17	11,5



Indexing plungers - Precision

with tapered pin



Material:

Steel.
Grip ball thermoplastic.

Version:

Hardened and ground.
Grip ball black grey.

Sample order:

K0359.020

Note:

The indexing plungers with bushes are a perfect combination for rapid positioning and fixing. The precise design of both the indexing plunger and the bush guarantees high repeating accuracy when assembling two elements.

Technical information see assembly and installation instructions.

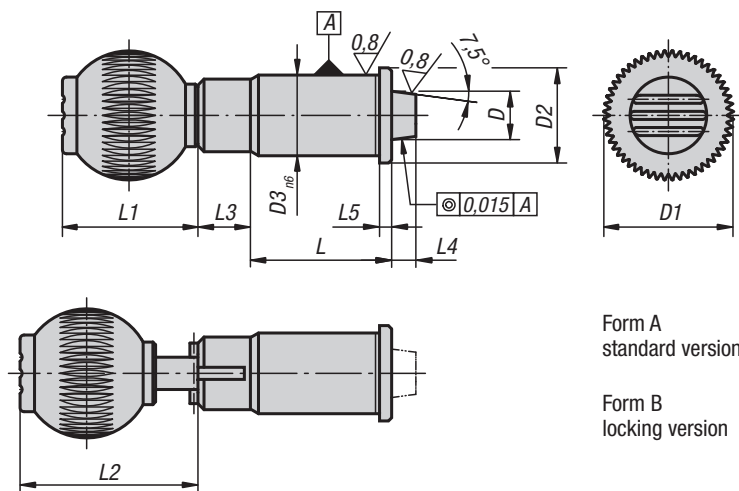

Form A
standard version

Form B
locking version

KIPP Precision indexing plungers with tapered pin

Order No. Form A	Order No. Form B	D	D1	D2	D3	L	L1	L2	L3	L4	L5	Spring force initial pressure F1 approx. N	Spring force final pressure F2 approx. N	Internal thread grip ball
K0359.010	K0359.110	10	25	19	16	31	25	-/32,5	13	6	2,5	19	29	M6
K0359.012	K0359.112	12	32	23	20	35	33	-/40,5	13	6	3	22	35	M8
K0359.016	K0359.116	16	40	28	25	42	41,5	-/49	13	6	3	30	50	M10
K0359.020	K0359.120	20	40	33	30	50	41,5	-/49	13	6	3	46	63	M10
K0359.025	K0359.125	25	50	42	38	60	51	-/58,5	13	6	3	39	73	M10

Bushes tapered

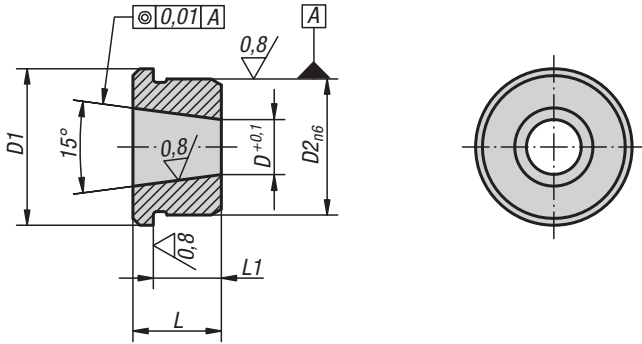

Material:
Steel.

Version:
Hardened and ground.

Sample order:
K0360.20

Note:
Bushes for precision indexing plungers K0359.



KIPP Tapered bushes

Order No.	D	D1	D2	L	L1
K0360.10	7,1	19	16	11	8,5
K0360.12	8,28	23	20	13	10
K0360.16	11,52	28	25	17	14
K0360.20	15,49	33	30	16	13
K0360.25	19,7	42	38	19	16

Indexing plungers - Precision

with cylindrical pin



Material:

Steel.
Grip ball thermoplastic.

Version:

Hardened and ground.
Grip ball black grey.

Sample order:

K0361.020

Note:

The indexing plungers with bushes are a perfect combination for rapid positioning and fixing. The precise design of both the indexing plungers and the bush guarantees high repeating accuracy when assembling two elements.

Technical Information see assembly and installation instructions.

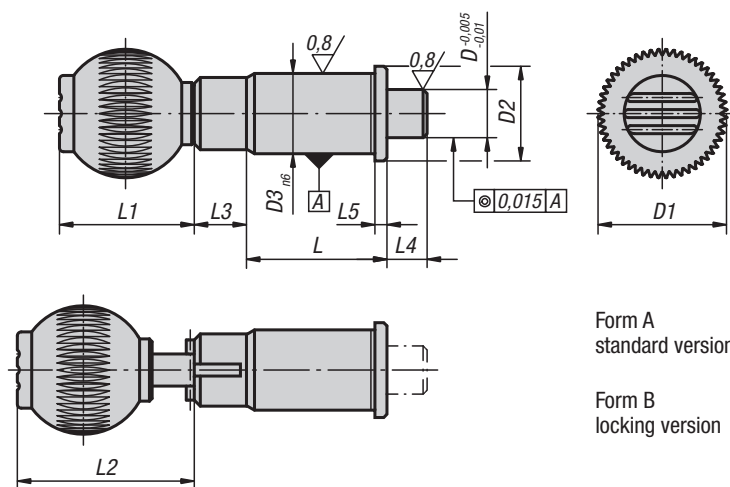

Form A
standard version

Form B
locking version

KIPP Precision indexing plungers with cylindrical pin

Order No. Form A	Order No. Form B	D	D1	D2	D3	L	L1	L2	L3	L4 min.	L5	Spring force initial pressure F1 approx. N	Spring force final pressure F2 approx. N	Internal thread grip ball
K0361.010	K0361.110	10	25	19	16	31	25	-/36,5	13	10	2,5	15	30	M6
K0361.012	K0361.112	12	32	23	20	35	33	-/44,5	13	10	3	15	35	M8
K0361.016	K0361.116	16	40	28	25	42	41,5	-/53	13	10	3	20	50	M10
K0361.020	K0361.120	20	40	33	30	50	41,5	-/53	13	10	3	36	63	M10
K0361.025	K0361.125	25	50	42	38	60	51	-/62,5	13	10	3	20	73	M10

Bushes cylindrical

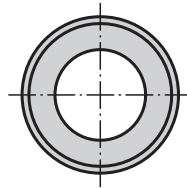
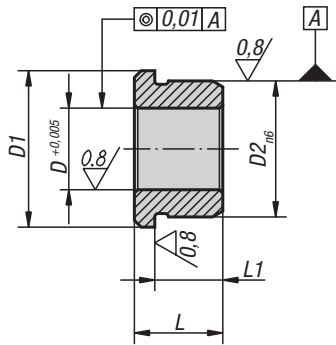

Material:
Steel.

Version:
Hardened and ground.

Sample order:
K0362.20

Note:
Bushes for precision indexing plungers K0361.

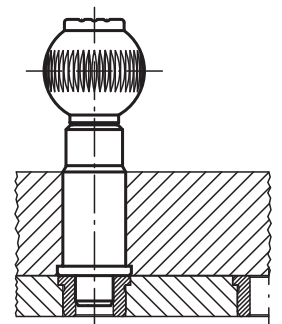

KIPP Cylindrical bushes

Order No.	D	D1	D2	L	L1
K0362.10	10	19	16	11	8,5
K0362.12	12	23	20	13	10
K0362.16	16	28	25	17	14
K0362.20	20	33	30	16	13
K0362.25	25	42	38	19	16

Assembly and installation instructions for precision indexing plungers

Precision indexing plungers with tapered indexing pin

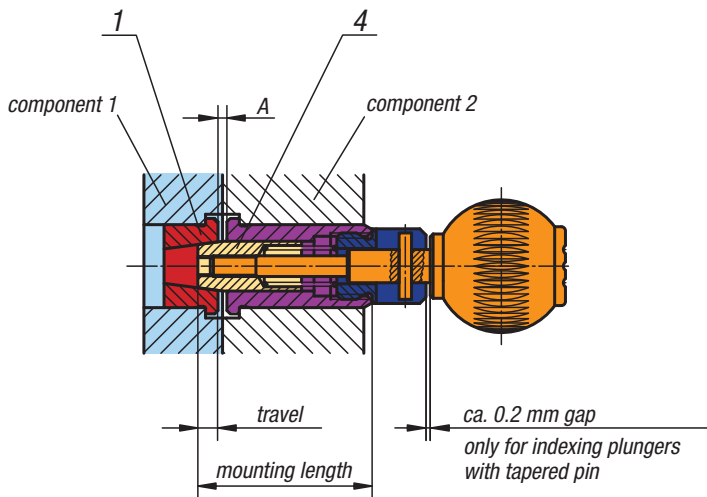

Precision indexing plungers with cylindrical indexing pin

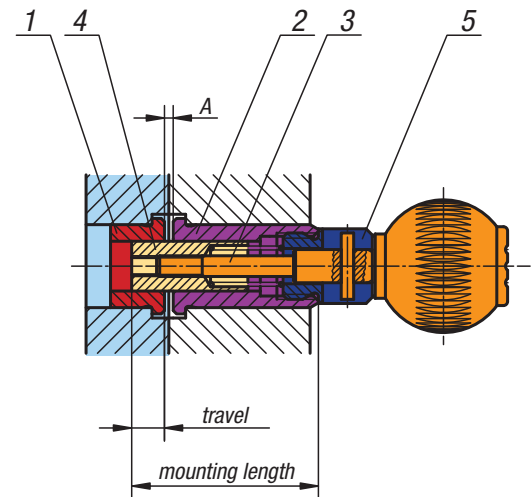

Assembly instructions:

1. Fit tapered or cylindrical bush (Pos. 1) into component 1.
2. Mount sleeve (Pos. 2) into component 2.
3. Determine mounting length (actual dimension). Mounting length = $A + \text{travel} + \text{length of Pos. 2}$. Models with tapered pin should have a 0.2 mm gap.
4. Glue screw (Pos. 3) and centring pin (Pos. 4) together grease-free with anaerobic adhesive. We recommend Loctite 638.
5. Screw centring pin with nut (Pos. 4) and handle into the mounted sleeve (Pos. 2). If necessary glue together grease-free with anaerobic adhesive.
6. Check whether the product is operational. Adhere to the index travel length given in the catalogue.

Note:
The precision indexing plunger is only ready for operation after the stated adhesive hardening time. When gluing the components, ensure that no adhesive enters into contact with movable parts.



Indexing and clamp grips

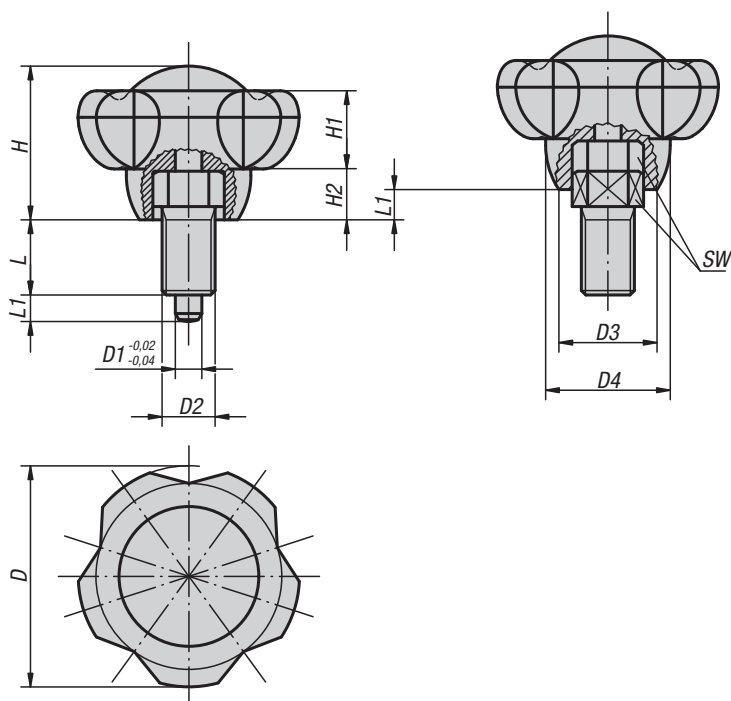

The Novo-Grip indexing and clamp grip allows indexing and clamping with one single product. Especially telescopic adjustments can be positioned and clamped quickly, precisely and simply.

Material:
Thermoplastic.
Indexing pin and screw steel 5.8.

Version:
Grip black grey.
Indexing pin and screw black oxidised.
Indexing pin hardened and ground.

Sample order:
K0245.11056 (cap colour traffic red)

Note:
Δ Add the desired cap colour here. No colour code is required with black grey grip caps.

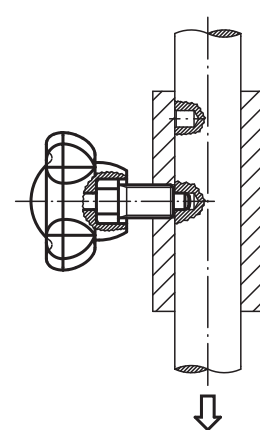

KIPP Locking and clamp grips

Order No.	Size	D	D1	D2	D3	D4	H	H1	H2	L	L1	SW
K0245.1105Δ	1	50	5	M10x1	22,2	28,2	34,8	17,8	11,5	13	5	13
K0245.1206Δ	2	50	6	M12x1,5	22,2	28,2	34,8	17,8	11,5	17	6	14
K0245.1308Δ	3	63	8	M16x1,5	28	35,5	44	22,5	14,5	22	8	19
K0245.1410Δ	4	63	10	M20x1,5	28	35,5	44	22,5	14,5	24	10	22

Cam-action indexing plungers

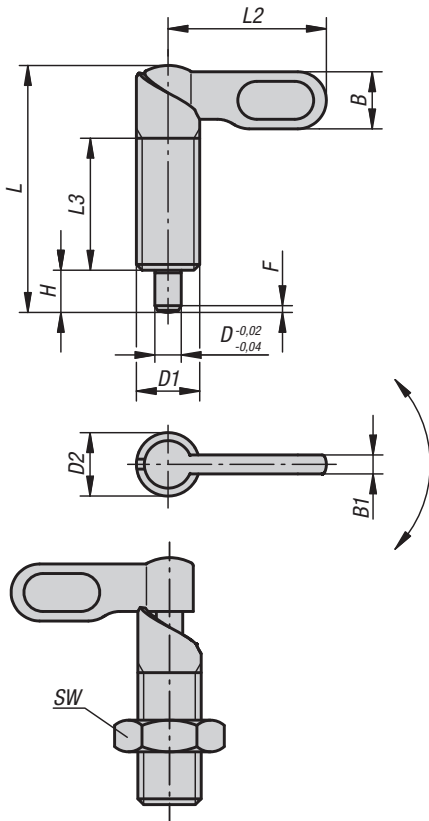

Form A
grip uncoated
without nut

Form C
grip powder-coated
without nut

Form B
grip uncoated
with nut

Form D
grip powder-coated
with nut



Material:
Steel grade 5.8.

Version:
Black oxidised.
Pin hardened and ground.

Sample order:
K0348.040616

Note:
Cam -action indexing plungers are used when the indexing pin should not project all the time. Turning the handle through 180° retracts the pin. A notch ensures that the handle remains in this position.

KIPP Cam-action indexing plungers

Order No. Form A	Order No. Form C	Order No. Form B	Order No. Form D	D	D1	D2	L	L2	L3	B	B1	H	SW	F x 30° initial pressure F1 approx. N	Spring force final pressure F2 approx. N	
K0348.040410	K0348.060410	K0348.050410	K0348.070410	4	M10	10	38	25	20	9	3	6	-/-/17/17	1	8	14
K0348.040510	K0348.060510	K0348.050510	K0348.070510	5	M10	10	38	25	20	9	3	6	-/-/17/17	1,3	8	14
K0348.040610	K0348.060610	K0348.050610	K0348.070610	6	M10	10	38	25	20	9	3	6	-/-/17/17	1,8	8	14
K0348.0404101	K0348.0604101	K0348.0504101	K0348.0704101	4	M10x1	10	38	25	20	9	3	6	-/-/17/17	1	8	14
K0348.0405101	K0348.0605101	K0348.0505101	K0348.0705101	5	M10x1	10	38	25	20	9	3	6	-/-/17/17	1,3	8	14
K0348.0406101	K0348.0606101	K0348.0506101	K0348.0706101	6	M10x1	10	38	25	20	9	3	6	-/-/17/17	1,8	8	14
K0348.040512	K0348.060512	K0348.050512	K0348.070512	5	M12	12	46,8	30	25	10,8	3,6	8	-/-/19/19	1,3	8	15
K0348.040612	K0348.060612	K0348.050612	K0348.070612	6	M12	12	46,8	30	25	10,8	3,6	8	-/-/19/19	1,8	8	15
K0348.040812	K0348.060812	K0348.050812	K0348.070812	8	M12	12	46,8	30	25	10,8	3,6	8	-/-/19/19	2,3	8	15
K0348.0405121	K0348.0605121	K0348.0505121	K0348.0705121	5	M12x1,5	12	46,8	30	25	10,8	3,6	8	-/-/19/19	1,3	8	15
K0348.0406121	K0348.0606121	K0348.0506121	K0348.0706121	6	M12x1,5	12	46,8	30	25	10,8	3,6	8	-/-/19/19	1,8	8	15
K0348.0408121	K0348.0608121	K0348.0508121	K0348.0708121	8	M12x1,5	12	46,8	30	25	10,8	3,6	8	-/-/19/19	2,3	8	15
K0348.040616	K0348.060616	K0348.050616	K0348.070616	6	M16	16	60,4	40	32	14,4	4,8	10	-/-/24/24	1,8	15	35
K0348.040816	K0348.060816	K0348.050816	K0348.070816	8	M16	16	60,4	40	32	14,4	4,8	10	-/-/24/24	2,3	15	35
K0348.041016	K0348.061016	K0348.051016	K0348.071016	10	M16	16	60,4	40	32	14,4	4,8	10	-/-/24/24	2,8	15	35
K0348.0406161	K0348.0606161	K0348.0506161	K0348.0706161	6	M16x1,5	16	60,4	40	32	14,4	4,8	10	-/-/24/24	1,8	15	35
K0348.0408161	K0348.0608161	K0348.0508161	K0348.0708161	8	M16x1,5	16	60,4	40	32	14,4	4,8	10	-/-/24/24	2,3	15	35
K0348.0410161	K0348.0610161	K0348.0510161	K0348.0710161	10	M16x1,5	16	60,4	40	32	14,4	4,8	10	-/-/24/24	2,8	15	35
K0348.040820	K0348.060820	K0348.050820	K0348.070820	8	M20	20	70	50	35	18	6	12	-/-/30/30	2,3	20	60
K0348.041020	K0348.061020	K0348.051020	K0348.071020	10	M20	20	70	50	35	18	6	12	-/-/30/30	2,8	20	60
K0348.041220	K0348.061220	K0348.051220	K0348.071220	12	M20	20	70	50	35	18	6	12	-/-/30/30	3	20	60
K0348.0408201	K0348.0608201	K0348.0508201	K0348.0708201	8	M20x1,5	20	70	50	35	18	6	12	-/-/30/30	2,3	20	60
K0348.0410201	K0348.0610201	K0348.0510201	K0348.0710201	10	M20x1,5	20	70	50	35	18	6	12	-/-/30/30	2,8	20	60
K0348.0412201	K0348.0612201	K0348.0512201	K0348.0712201	12	M20x1,5	20	70	50	35	18	6	12	-/-/30/30	3	20	60

Cam-action indexing plungers

stainless steel

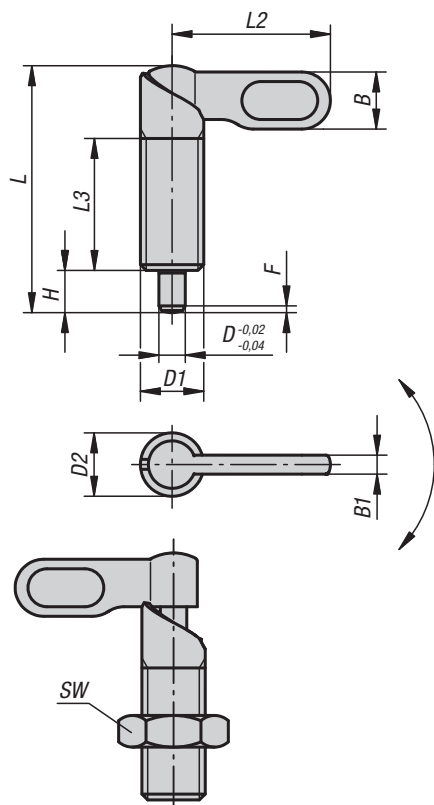

Form A
grip uncoated
without nut

Form B
grip uncoated
with nut



Material:
Stainless steel 1.4305.

Version:
Bright. Indexing pin ground, not hardened.

Sample order:
K0637.1040616

Note:
Cam-action indexing plungers are used when the indexing pin should not project all the time. Turning the handle through 180° retracts the pin. A notch ensures that the handle remains in this position.

KIPP Cam-action indexing plungers stainless steel

Order No. Form A	Order No. Form B	D	D1	D2	L	L2	L3	B	B1	H	SW	F x 30°	Spring force initial pressure F1 approx. N	Spring force final pressure F2 approx. N
K0637.1040410	K0637.1050410	4	M10	10	38	25	20	9	3	6	-17	1	8	14
K0637.1040510	K0637.1050510	5	M10	10	38	25	20	9	3	6	-17	1,3	8	14
K0637.1040610	K0637.1050610	6	M10	10	38	25	20	9	3	6	-17	1,8	8	14
K0637.10404101	K0637.10504101	4	M10x1	10	38	25	20	9	3	6	-17	1	8	14
K0637.10405101	K0637.10505101	5	M10x1	10	38	25	20	9	3	6	-17	1,3	8	14
K0637.10406101	K0637.10506101	6	M10x1	10	38	25	20	9	3	6	-17	1,8	8	14
K0637.1040512	K0637.1050512	5	M12	12	46,8	30	25	10,8	3,6	8	-19	1,3	8	15
K0637.1040612	K0637.1050612	6	M12	12	46,8	30	25	10,8	3,6	8	-19	1,8	8	15
K0637.1040812	K0637.1050812	8	M12	12	46,8	30	25	10,8	3,6	8	-19	2,3	8	15
K0637.10405121	K0637.10505121	5	M12x1,5	12	46,8	30	25	10,8	3,6	8	-19	1,3	8	15
K0637.10406121	K0637.10506121	6	M12x1,5	12	46,8	30	25	10,8	3,6	8	-19	1,8	8	15
K0637.10408121	K0637.10508121	8	M12x1,5	12	46,8	30	25	10,8	3,6	8	-19	2,3	8	15
K0637.1040616	K0637.1050616	6	M16	16	60,4	40	32	14,4	4,8	10	-24	1,8	15	35
K0637.1040816	K0637.1050816	8	M16	16	60,4	40	32	14,4	4,8	10	-24	2,3	15	35
K0637.1041016	K0637.1051016	10	M16	16	60,4	40	32	14,4	4,8	10	-24	2,8	15	35
K0637.10406161	K0637.10506161	6	M16x1,5	16	60,4	40	32	14,4	4,8	10	-24	1,8	15	35
K0637.10408161	K0637.10508161	8	M16x1,5	16	60,4	40	32	14,4	4,8	10	-24	2,3	15	35
K0637.10410161	K0637.10510161	10	M16x1,5	16	60,4	40	32	14,4	4,8	10	-24	2,8	15	35
K0637.1040820	K0637.1050820	8	M20	20	70	50	35	18	6	12	-30	2,3	20	60
K0637.1041020	K0637.1051020	10	M20	20	70	50	35	18	6	12	-30	2,8	20	60
K0637.1041220	K0637.1051220	12	M20	20	70	50	35	18	6	12	-30	3	20	60
K0637.10408201	K0637.10508201	8	M20x1,5	20	70	50	35	18	6	12	-30	2,3	20	60
K0637.10410201	K0637.10510201	10	M20x1,5	20	70	50	35	18	6	12	-30	2,8	20	60
K0637.10412201	K0637.10512201	12	M20x1,5	20	70	50	35	18	6	12	-30	3	20	60



Mounting brackets

aluminium

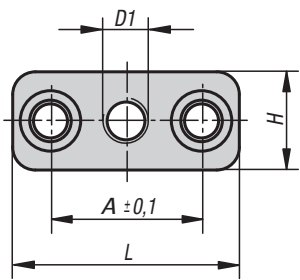

Form A
Fastening hole
parallel to thread

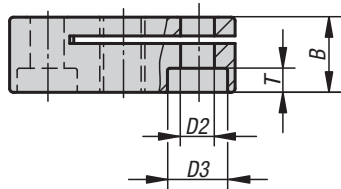

Material:
Aluminium 3.2163

Version:
Black anodized

Sample order:
K0638.308

Note:
Mounting brackets are an assembly aid for cam-
action and other indexing plungers and expand the
application field. For use with socket head screws DIN
912 / ISO 4762.

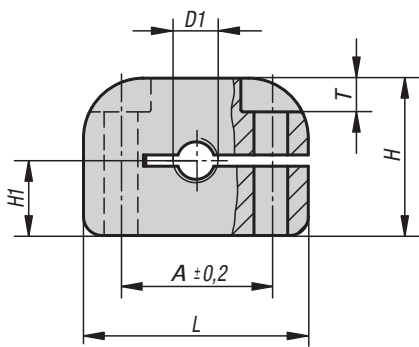

Form B
Fastening hole
vertical to thread

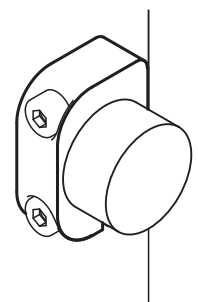
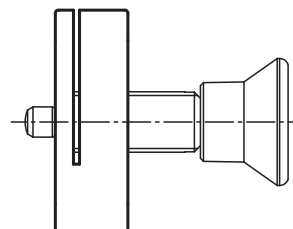
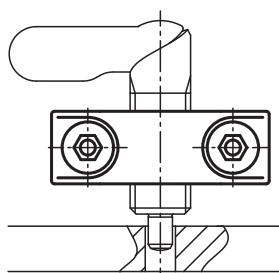
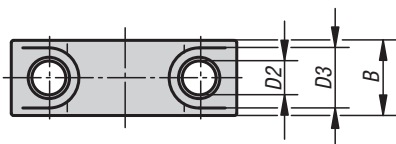

Mounting brackets

aluminium



KIPP Mounting bracket aluminium

Order No.	Form	D1	D2	D3	A	B	H	H1	L	T
K0638.306	A	M6	4,5	8	20	10	13	-	30	3,2
K0638.3061	A	M6x0,75	4,5	8	20	10	13	-	30	3,2
K0638.308	A	M8	4,5	8	20	10	13	-	30	3,2
K0638.3081	A	M8x1	4,5	8	20	10	13	-	30	3,2
K0638.310	A	M10	5,5	10	24	12	18	-	37	3,9
K0638.3101	A	M10x1	5,5	10	24	12	18	-	37	3,9
K0638.312	A	M12	5,5	10	24	12	18	-	37	3,9
K0638.3121	A	M12x1,5	5,5	10	24	12	18	-	37	3,9
K0638.316	A	M16	5,5	10	32	15	25	-	46	3,9
K0638.3161	A	M16x1,5	5,5	10	32	15	25	-	46	3,9
K0638.320	A	M20	5,5	10	32	15	25	-	46	3,9
K0638.3201	A	M20x1,5	5,5	10	32	15	25	-	46	3,9
K0638.406	B	M6	4,5	8	20	10	21	10	30	4,5
K0638.4061	B	M6x0,75	4,5	8	20	10	21	10	30	4,5
K0638.408	B	M8	4,5	8	20	10	21	10	30	4,5
K0638.4081	B	M8x1	4,5	8	20	10	21	10	30	4,5
K0638.410	B	M10	5,5	10	24	12	26	13	36	5,5
K0638.4101	B	M10x1	5,5	10	24	12	26	13	36	5,5
K0638.412	B	M12	5,5	10	24	12	26	13	36	5,5
K0638.4121	B	M12x1,5	5,5	10	24	12	26	13	36	5,5
K0638.416	B	M16	5,5	10	32	15	29	17	46	5,5
K0638.4161	B	M16x1,5	5,5	10	32	15	29	17	46	5,5
K0638.420	B	M20	5,5	10	32	15	29	17	46	5,5
K0638.4201	B	M20x1,5	5,5	10	32	15	29	17	46	5,5



Mounting brackets

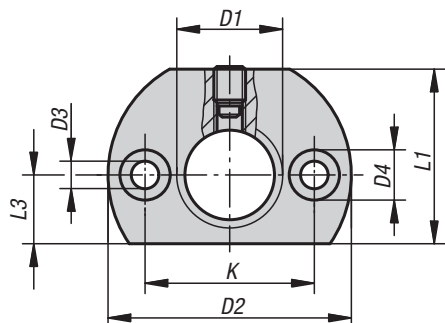

Form A
fastening hole parallel
to indexing plunger

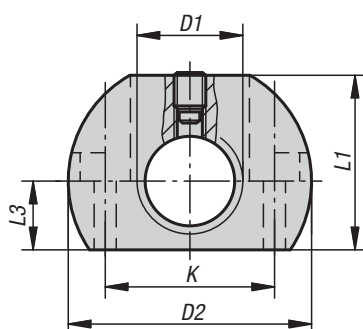
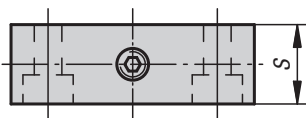

Form B
fastening hole vertical
to indexing plunger

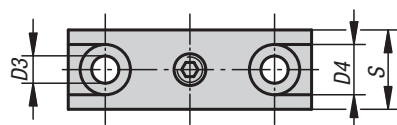

Material:
Steel.

Version:
Black oxidised.

Sample order:
K0638.116

Note:
Mounting brackets are assembly aids for cam-action indexing plungers and extend their application field. They can also be used for other indexing plungers.

KIPP Mounting brackets

Order No.	Form	D1	D2	D3	D4	K	L1	L3	S
K0638.112	A	M12	36	5,5	10	24	25	10	12
K0638.1121	A	M12x1,5	36	5,5	10	24	25	10	12
K0638.116	A	M16	46	5,5	10	32	33	13	15
K0638.1161	A	M16x1,5	46	5,5	10	32	33	13	15
K0638.120	A	M20	46	5,5	10	32	33	13	15
K0638.1201	A	M20x1,5	46	5,5	10	32	33	13	15
K0638.212	B	M12	36	5,5	10	24	25	10	12
K0638.2121	B	M12x1,5	36	5,5	10	24	25	10	12
K0638.216	B	M16	46	5,5	10	32	33	13	15
K0638.2161	B	M16x1,5	46	5,5	10	32	33	13	15
K0638.220	B	M20	46	5,5	10	32	33	13	15
K0638.2201	B	M20x1,5	46	5,5	10	32	33	13	15

Cam-action indexing plungers



Material:
Handle 1.0503.
Pin steel grade 5.8.
Sleeve 1.0403 weldable.

Version:
Black oxidised.
Pin hardened and ground.

Sample order:
K0639.091220

Note:
Cam-action indexing plungers are used when the indexing pin should not project all the time. Turning the handle through 180° retracts the pin.
A notch ensures that the handle remains in this position.
To weld the plungers we recommend inert gas shielded welding with TIG welding equipment.

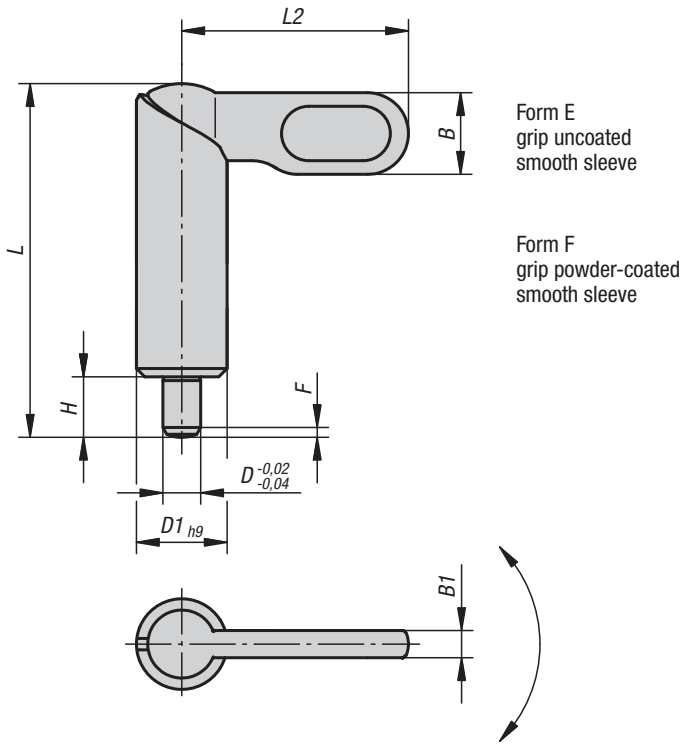

KIPP Cam-action indexing plungers

Order No. Form E	Order No. Form F	D	D1	L	L2	B	B1	H	F x 30°	Spring force initial pressure F1 approx. N	Spring force final pressure F2 approx. N
K0639.080410	K0639.090410	4	10	38	25	9	3	6	1	8	14
K0639.080510	K0639.090510	5	10	38	25	9	3	6	1,3	8	14
K0639.080610	K0639.090610	6	10	38	25	9	3	6	1,8	8	14
K0639.080512	K0639.090512	5	12	46,8	30	10,8	3,6	8	1,3	8	15
K0639.080612	K0639.090612	6	12	46,8	30	10,8	3,6	8	1,8	8	15
K0639.080812	K0639.090812	8	12	46,8	30	10,8	3,6	8	2,3	8	15
K0639.080616	K0639.090616	6	16	60,4	40	14,4	4,8	10	1,8	15	35
K0639.080816	K0639.090816	8	16	60,4	40	14,4	4,8	10	2,3	15	35
K0639.081016	K0639.091016	10	16	60,4	40	14,4	4,8	10	2,8	15	35
K0639.080820	K0639.090820	8	20	70	50	18	6	12	2,3	20	60
K0639.081020	K0639.091020	10	20	70	50	18	6	12	2,8	20	60
K0639.081220	K0639.091220	12	20	70	50	18	6	12	3	20	60

Cam-action indexing plungers

stainless steel

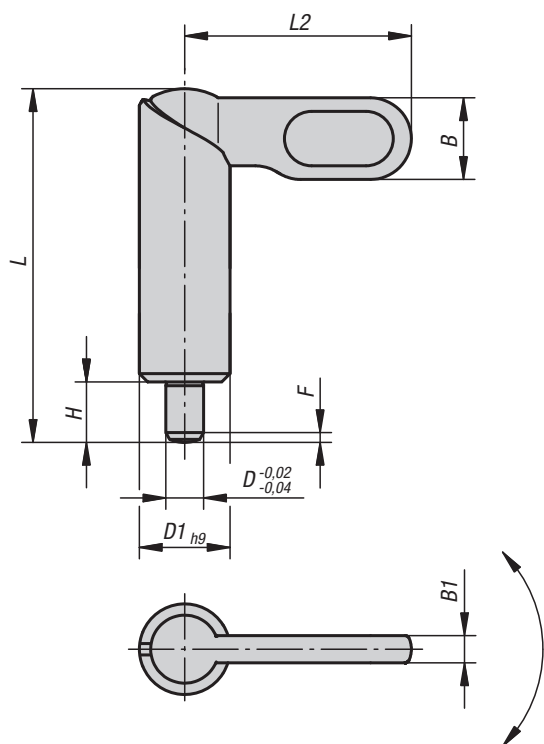

Form E
grip uncoated
smooth sleeve

Material:

Handle stainless steel 1.4308.
Indexing pin stainless steel 1.4305.
Sleeve weldable stainless steel 1.4301.

Version:

Bright. Indexing pin ground, not hardened.

Sample order:

K0640.1081220

Note:

Cam-action indexing plungers are used when the indexing pin should not project all the time. Turning the handle through 180° retracts the pin. A notch ensures that the handle remains in this position. To weld the plungers we recommend inert gas shielded welding with TIG welding equipment.

KIPP Cam-action indexing plungers stainless steel

Order No.	Form	D	D1	L	L2	B	B1	H	F x 30°	Spring force initial pressure F1 approx. N	Spring force final pressure F2 approx. N
K0640.1080410	E	4	10	38	25	9	3	6	1	8	14
K0640.1080510	E	5	10	38	25	9	3	6	1,3	8	14
K0640.1080610	E	6	10	38	25	9	3	6	1,8	8	14
K0640.1080512	E	5	12	46,8	30	10,8	3,6	8	1,3	8	15
K0640.1080612	E	6	12	46,8	30	10,8	3,6	8	1,8	8	15
K0640.1080812	E	8	12	46,8	30	10,8	3,6	8	2,3	8	15
K0640.1080616	E	6	16	60,4	40	14,4	4,8	10	1,8	15	35
K0640.1080816	E	8	16	60,4	40	14,4	4,8	10	2,3	15	35
K0640.1081016	E	10	16	60,4	40	14,4	4,8	10	2,8	15	35
K0640.1080820	E	8	20	70	50	18	6	12	2,3	20	60
K0640.1081020	E	10	20	70	50	18	6	12	2,8	20	60
K0640.1081220	E	12	20	70	50	18	6	12	3	20	60

Barrel slide bolts



Material:

Housing die-cast zinc.
Grip, underlay and slot tabs thermoplastic PA.
Bolt stainless steel.

Version:

Housing painted silver.
Grip, underlay and slot tabs black.
Bolt bright.

Sample order:

K0349.38038028

Note:

Spring loaded bolt.
Supplied with:
- 2 underlays for mounting on level surfaces.
- 2 of each tabs for mounting on profiles with 8 or 10 mm slots.

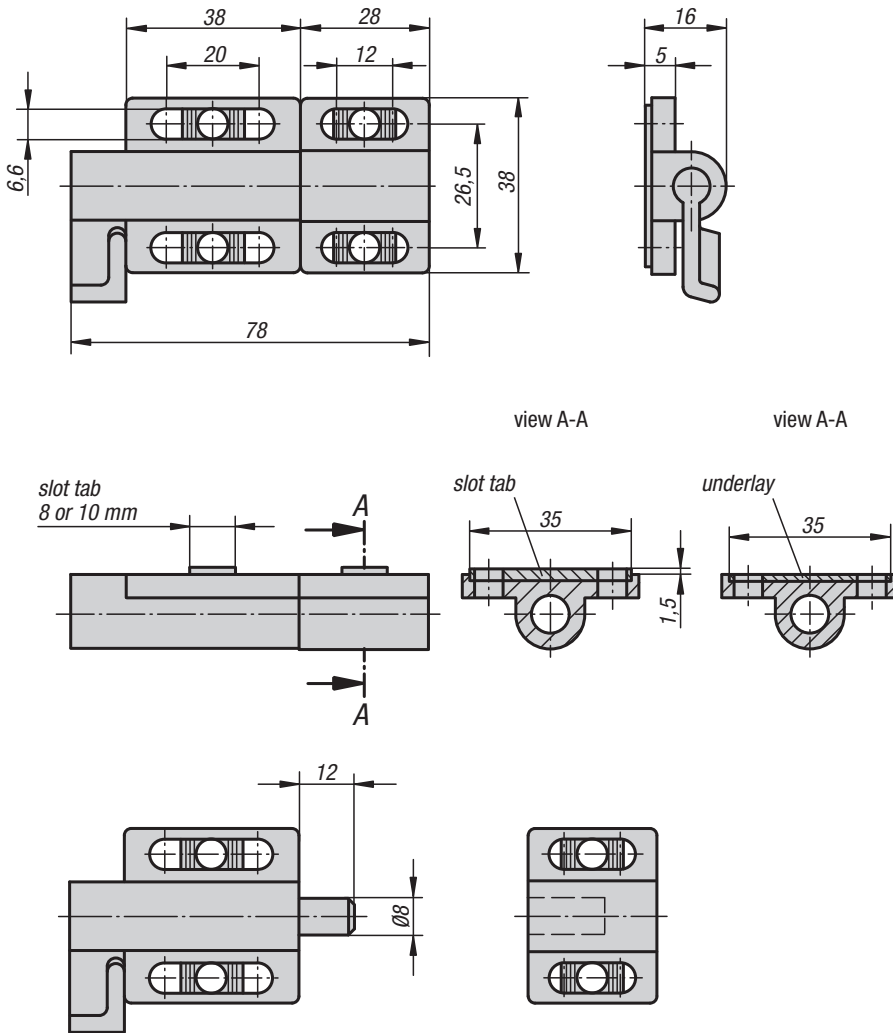

KIPP Barrel slide bolts

Order No.	Spring force initial pressure F1 approx. N	Spring force final pressure F2 approx. N
K0349.38038028	5	15

Ball lock pins

self-locking



Form A

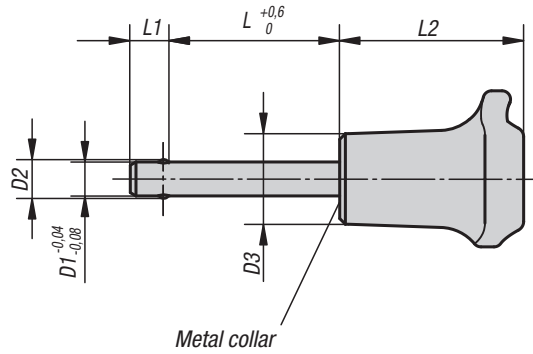
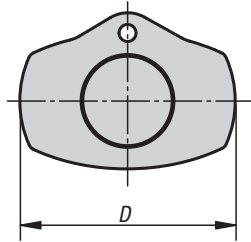

Form B

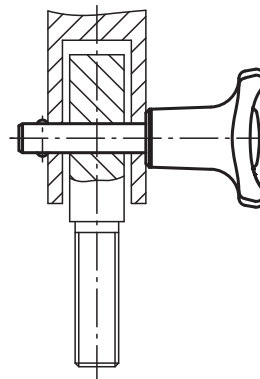
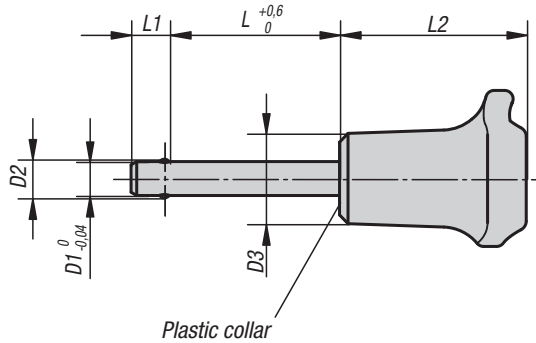
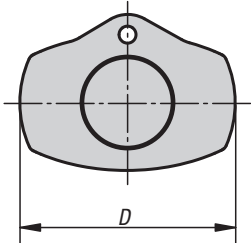

Material:
Grip and push button thermoplastic.
Metal parts stainless steel.

Version:
Grip black.
Push button traffic red.
Steel parts bright.

Sample order:
K0363.3806050
(include length L e.g. 050 for L = 50 mm.)

Note:
Ball lock pins are used for quick and easy fastening and joining of parts and workpieces. The two balls are disengaged by pressing the push button and the pin can be slipped into holes in the workpieces. Release the button to lock the balls and secure the connection. Form A is suitable for applications where high demands and precision are required.

Shearing force double shear (F) = S · τ aB max.

Characteristics:
Form A:
Pin ground, metal collar, high axial pull-out force
Form B:
Pin h9, plastic collar, low axial pull-out force

Accessories:
Safety spiral cable K0367.10200
Retaining cable with loop K0367.
Key ring K0367.15/19/23
Bushing for ball lock pins K0724....

KIPP Ball lock pins, self-locking, Form A

Order No.	D	D1	D2	D3	L	L1	L2	Receiving hole H11	Shearing force double shear max. kN
K0363.3805***	38	5	5,5	16	10/15/20/25/30	6	32,5	5	15
K0363.3806***	38	6	6,85	16	10/15/20/25/30/35/40/45/50	7	32,5	6	22
K0363.3808***	38	8	9,5	16	20/25/30/35/40/45/50	8	32,5	8	38
K0363.4710***	47	10	12	23	20/25/30/35/40/45/50/60	9	40	10	60
K0363.4712***	47	12	14,5	23	25/30/35/40/45/50/60/70/80	10	40	12	86
K0363.4716***	47	16	19	23	30/35/40/45/50/60/70/80	13	40	16	153

KIPP Ball lock pins, self-locking, Form B

Order No.	D	D1	D2	D3	L	L1	L2	Receiving hole H11	Shearing force double shear max. kN
K0363.1380***	38	5	5,5	16	15/20/25/30	5,9	33	5	15
K0363.1380***	38	6	6,85	16	30/40/50	6,8	33	6	22
K0363.1380***	38	8	9,5	16	30/40/50	7,8	33	8	38

Ball lock pins

self-locking stainless steel

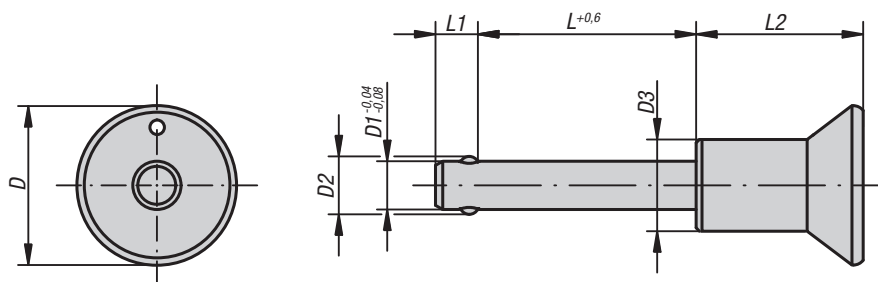

Material:

Metal parts stainless steel.

Version:

Bright.

Sample order:

K0364.3110030

(include length L e.g. 030 for L = 30 mm)

Note:

Ball lock pins are used for quick and easy fastening and joining of parts and workpieces.

The two balls are disengaged by pressing the push button and the pin can be slipped into holes in the workpieces. Release the button to lock the balls and secure the connection.

Corrosion resistant. Option for connecting retaining cable. Application temperature max. +250 °C.

Shearing force double shear (F) = S · τ aB max.

Accessories:

Safety spiral cable K0367.10200

Retaining cable with loop K0367.

Key ring K0367.15/19/23

Bushing for ball lock pins K0724....

KIPP Ball lock pins self-locking stainless steel

Order No.	D	D1	D2	D3	L	L1	L2	Receiving hole H11	Shearing force double shear max. kN
K0364.2305***	25	5	5,5	14	10/15/20/25/30	6	26,5	5	15
K0364.2306***	25	6	6,85	14	10/15/20/25/30/35/40/45/50	7	26,5	6	22
K0364.2308***	25	8	9,5	14	20/25/30/35/40/45/50	8	26,5	8	38
K0364.3110***	33	10	12	19	20/25/30/35/40/45/50/60	9	34,6	10	60
K0364.3112***	33	12	14,5	19	25/30/35/40/45/50/60/70/80	10	34,6	12	86
K0364.3116***	33	16	19	20	30/35/40/45/50/60/70/80	13,3	34,6	16	153

Ball lock pins

stainless steel, self-locking



Form A

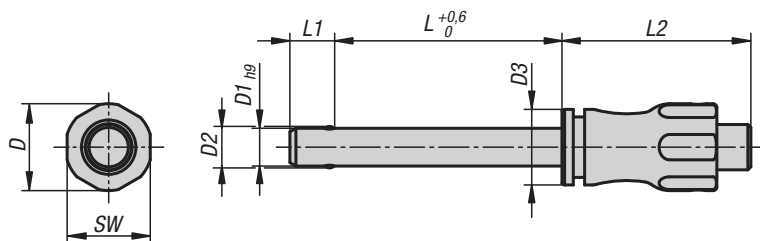

Form B

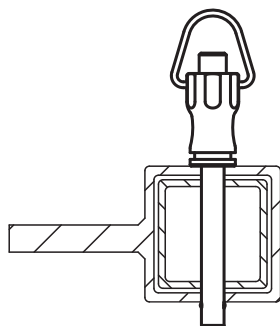
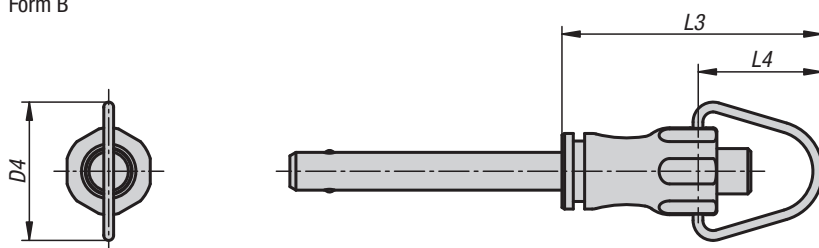

Material:

Grip and push button stainless steel 1.4305.

Pin stainless steel 1.4305.

Balls stainless steel 1.4125.

Compression spring and handle stainless steel 1.4310.

Version:

Bright.

Sample order:

K0790.001508050

(include length L e.g. 050 for L = 50 mm)

Note:

Ball lock pins are used for quick and easy fastening and joining of parts and workpieces.

The two balls are disengaged by pressing the push button and the pin can be slipped into holes in the workpieces. Release the button to lock the balls and secure the connection.

Shearing force double-shear (F) = S · τ aB max.

Accessories:

Safety spiral cable K0367.10200

Retaining cable with loop K0367.

Key ring K0367.15/19/23

Bushing for ball lock pins K0724....

KIPP Ball lock pins stainless steel self-locking, Form A

Order No.	Form	D	D1	D2	D3	L	L1	L2	SW	Receiving hole H11	Shearing force double shear max.kN
K0790.001205***	A	11,5	5	5,5	10	10/15/20/25/30	5,9	25	11	5	15
K0790.001206***	A	11,5	6	6,85	10	10/15/20/25/30/35/40/45/50	6,8	25	11	6	22
K0790.001508***	A	15,5	8	9,5	13,5	20/25/30/35/40/45/50	7,8	33	15	8	38
K0790.001510***	A	15,5	10	12	13,5	20/25/30/35/40/45/50/60	8,9	33	15	10	60
K0790.002112***	A	22	12	14,5	20	25/30/35/40/45/50/60/70/80	9,9	39,5	21	12	86
K0790.002116***	A	22	16	19	20	30/35/40/45/50/60/70/80	13,1	39,5	21	16	153

KIPP Ball lock pins stainless steel self-locking, Form B

Order No.	Form	D	D1	D2	D3	D4	L	L1	L2	L3	L4	SW	Receiving hole H11	Shearing force double shear max.kN
K0790.101205***	B	11,5	5	5,5	10	18,3	10/15/20/25/30	5,9	25	34,6	16,6	11	5	15
K0790.101206***	B	11,5	6	6,85	10	18,3	10/15/20/25/30/35/40/45/50	6,8	25	34,6	16,6	11	6	22
K0790.101508***	B	15,5	8	9,5	13,5	24	20/25/30/35/40/45/50	7,8	33	46,7	22,7	15	8	38
K0790.101510***	B	15,5	10	12	13,5	24	20/25/30/35/40/45/50/60	8,9	33	46,7	22,7	15	10	60
K0790.102112***	B	22	12	14,5	20	33	25/30/35/40/45/50/60/70/80	9,9	39,5	59,3	30,3	21	12	86
K0790.102116***	B	22	16	19	20	33	30/35/40/45/50/60/70/80	13,1	39,5	59,3	30,3	21	16	153

Ball lock pins with mushroom knob

stainless steel, self-locking

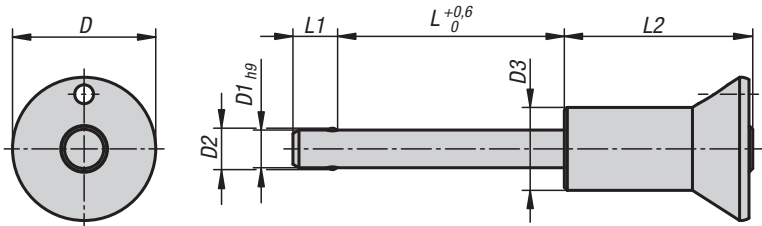

Material:

Mushroom knob and push button stainless steel 1.4305.
 Pin stainless steel 1.4305.
 Balls stainless steel 1.4125.
 Compression spring stainless steel 1.4310.

Version:

Bright.

Sample order:

K0791.02510050
 (include length L e.g. 050 for L = 50 mm)

Note:

Ball lock pins are used for quick and easy fastening and joining of parts and workpieces. The two balls are disengaged by pressing the push button and the pin can be slipped into holes in the workpieces. Release the button to lock the balls and secure the connection.

Shearing force double-shear (F) = S · τ aB max.

Accessories:

Safety spiral cable K0367.10200
 Retaining cable with loop K0367.
 Key ring K0367.15/19/23
 Bushing for ball lock pins K0724....

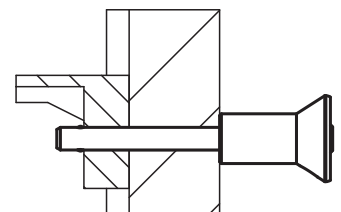

KIPP Ball lock pins with mushroom knob stainless steel self-locking

Order No.	D	D1	D2	D3	L	L1	L2	Receiving hole H11	Shearing force double shear max.kN
K0791.01905***	19	5	5,5	11	10/15/20/25/30	5,9	25	5	15
K0791.01906***	19	6	6,85	11	10/15/20/25/30/35/40/45/50	6,8	25	6	22
K0791.02508***	25	8	9,5	14	20/25/30/35/40/45/50	7,8	33	8	38
K0791.02510***	25	10	12	14	20/25/30/35/40/45/50/60	8,9	33	10	60
K0791.03512***	35	12	14,5	22	25/30/35/40/45/50/60/70/80	9,9	39,5	12	86
K0791.03516***	35	16	19	22	30/35/40/45/50/60/70/80	13,1	39,5	16	153

Ball lock pins

with mushroom knob, self-locking, stainless steel

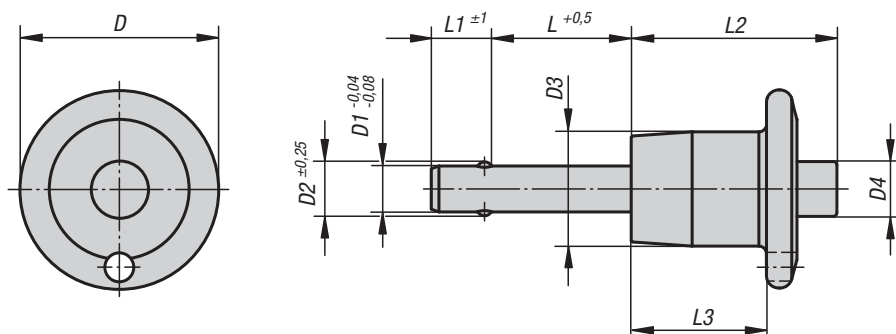

Material:

Pin stainless steel 1.4542.
Mushroom knob and push button stainless steel 1.4305.
Balls stainless steel 1.4125.
Compression spring stainless steel.

Version:

All stainless steel parts passivated.
Pin hardened to min. 40 HRC.
Balls hardened to 58 +4 HRC.

Sample order:

K0641.02105030
(include length L e.g. 030 for L = 30 mm.)

Note:

Ball lock pins are used for quick and easy fastening and joining of parts and workpieces. The two balls are disengaged by pressing the push button and the pin can be slipped into holes in the workpieces. Release the button to lock the balls and secure the connection. An option for connecting a retaining cable is provided.

Shearing force double shear (F) = S · τ aB max.

Accessories:

Safety spiral cable K0367.10200
Retaining cable with loop K0367.
Key ring K0367.15/19/23
Bushing for ball lock pins K0724....

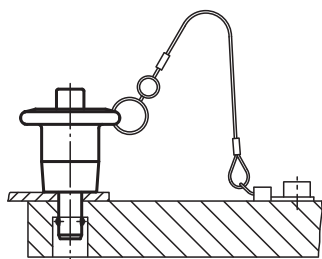

KIPP Ball lock pins with mushroom knob, self-locking, stainless steel

Order No.	D	D1	D2	D3	D4	L	L1	L2	L3	Receiving hole H11	Shearing force double shear max.kN
K0641.02105***	20,6	5	5,54	11,9	5,8	10/15/20/25/30/35/40/50/60/70	6	23,4	16	5	24,40
K0641.02106***	20,6	6	6,99	11,9	5,8	10/15/20/25/30/35/40/50/60/70/80	7	23,4	16	6	35,64
K0641.02108***	20,6	8	9,42	11,9	5,8	10/15/20/25/30/35/40/50/60/70/80	8	23,4	16	8	63,80
K0641.02510***	25,4	10	11,86	14,2	7,4	15/20/25/30/35/40/50/60/70/80/90/100	9	25,7	17,8	10	100,10
K0641.03512***	34,7	12	14,45	18,3	10,7	20/25/30/35/40/50/60/70/80/90/100	10	32,3	21,6	12	144,06

Ball lock pins

with grip ring, self-locking, stainless steel

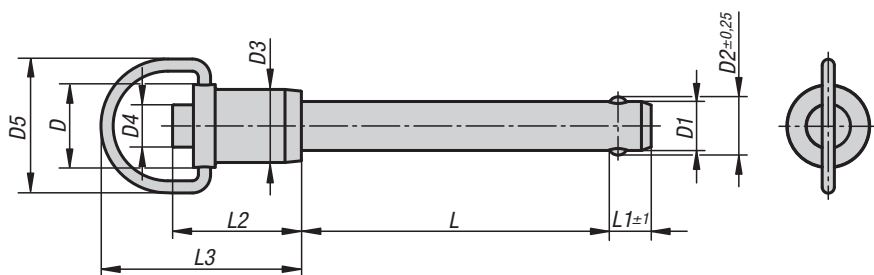

Material:

Pin stainless steel 1.4542.
 Head and push button stainless steel 1.4305.
 Balls stainless steel 1.4125.
 Spring stainless steel.
 Grip ring and key ring stainless steel.

Version:

All stainless steel parts passivated.
 Pin, hardened to min. 40 HRC.
 Balls hardened to 58 +4 HRC.

Sample order:

K0746.01505030
 (Include length L e.g. 030 for L = 30 mm)

Note:

Ball lock pins are used for quick and easy fastening and joining of parts and workpieces. The two balls are disengaged by pressing the push button and the pin can be slipped into holes in the workpieces. Release the button to lock the balls and secure the connection. The ball lock pins can be provided with a retaining cable if required.

The hardened, high-tensile stainless steel pin permits extreme loads with low wear. The high corrosion and acid resistance allow use in the foodstuff, chemical and petrochemical industries and as aerospace construction elements.

Shearing force double shear (F) = S · τ · aB max.

Accessories:

Safety spiral cable K0367.10200
 Retaining cable with loop K0367.
 Key ring K0367.15/19/23
 Bushing for ball lock pins K0724....

KIPP Ball lock pins with grip ring, self-locking, stainless steel

Order No.	D	D1	D2	D3	D4	D5	L	L1	L2	L3	Receiver hole H11	Shearing force double shear max. kN
K0746.01505***	15	5	5,54	11,9	5,8	29,5	10/15/20/25/30/35/40/45/50/60/70/80/90/100	6	23,4	36,8	5	24,4
K0746.01506***	15	6	6,99	11,9	5,8	29,5	10/15/20/25/30/35/40/45/50/60/70/80/90/100	7	23,4	36,8	6	35,64
K0746.01508***	15	8	9,42	11,9	5,8	29,5	10/15/20/25/30/35/40/45/50/60/70/80/90/100	8	23,4	36,8	8	63,8
K0746.01710***	16,5	10	11,86	14,2	7,4	29,5	15/20/25/30/35/40/45/50/60/70/80/90/100	9	25,7	38,6	10	100,1
K0746.02112***	20,6	12	14,45	18,3	10,7	36,3	20/25/30/35/40/45/50/60/70/80/90/100	10	32,3	47,8	12	144,06
K0746.02716***	26,9	16	19	23,9	13,7	43,7	25/30/35/40/45/50/60/70/80/90/100	14	41,9	65,3	16	257,18

Locking pins

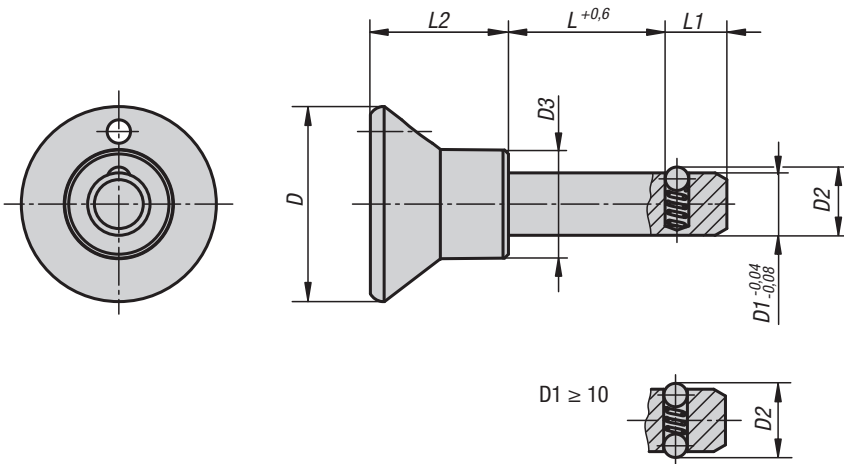

Material:
Grip thermoplastic.
Steel parts stainless steel.

Version:
Grip black.
Steel parts bright.

Sample order:
K0365.2508020

Note:
Locking pins are used for quick and easy fixating and joining of parts and workpieces.

Shearing force double-shear (F) = S · τ aB max.

Accessories:
Safety spiral cable K0367.10200
Retaining cable with loop K0367.
Key ring K0367.15/19/23
Bushing for ball lock pins K0724....

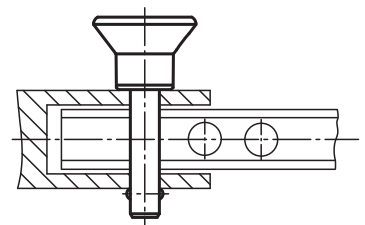

KIPP Locking pins

Order No.	D	D1	D2	D3	L	L1	L2	Receiving hole H11	Shearing force double shear max.kN
K0365.2506***	25	6	6,5	14	10/15/20/25/30/40/50	7	17,7	6	22
K0365.2508***	25	8	8,75	14	15/20/25/30/40/50	8	17,7	8	38
K0365.3310***	33	10	12	19	15/20/25/30/40/50	9	24	10	60
K0365.3312***	33	12	14,5	19	20/30/40/50	10	24	12	86

Locking pins with key ring

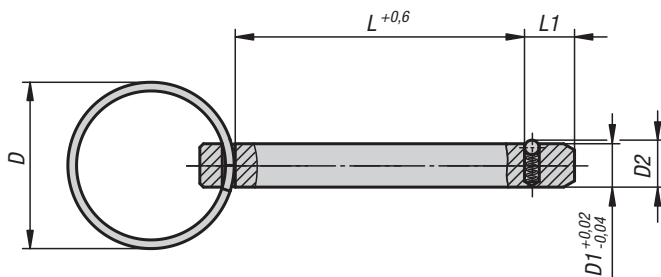
**Material:**

Steel pin.
Key ring stainless steel.

Version:

Pins galvanized.
Key ring bright.

Sample order:

K0365.102306020
(include length L e.g. 020 for L = 20 mm.)

Note:

Locking pins are used for fast and easy fixing and joining of parts and workpieces.

Shearing force double shear (F) = S · τ aB max.

The locking pins with key ring represent a cost-effective alternative to other locking pins.



KIPP Locking pins with key ring

Order No.	D	D1	D2	L	L1	Shearing force double shear max.kN
K0365.102306015	23	6	6,5	15	7	22
K0365.102306020	23	6	6,5	20	7	22
K0365.102306030	23	6	6,5	30	7	22
K0365.102306040	23	6	6,5	40	7	22
K0365.102808030	28	8	8,8	30	8	38
K0365.102808040	28	8	8,8	40	8	38
K0365.102808050	28	8	8,8	50	8	38

Locking pins with folding latch



Material:
Steel galvanized.

Sample order:
K0776.06025

Note:
Locking pins with folding latch are not only used for fast and easy fixing but also for permanent joining of movable parts and workpieces. The wide folding latch lets you secure the parts to be joined over a large cross section. It can also work under pressure in the axial direction. Indexing slots in the folding latch allow definite „Closed“ and „Open“ positions.

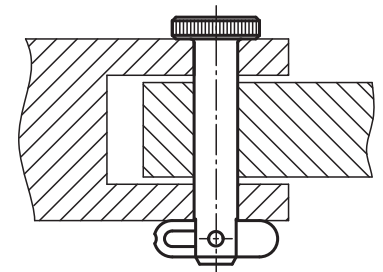
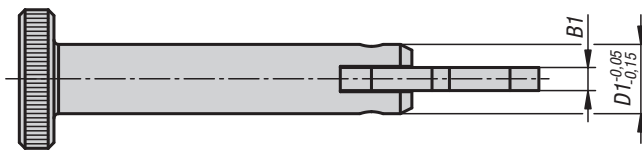
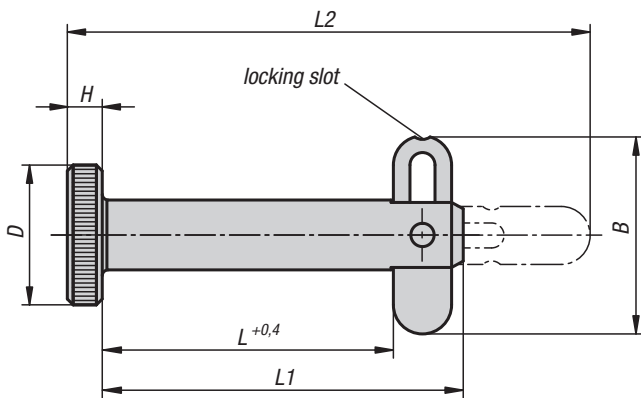

KIPP Locking pins with folding latch

Order No.	D	D1	L	L1	L2	H	B	B1	Receiving hole H11	Shearing force double shear max.kN	Extraction force F in N
K0776.06025	12	6	25	31	45	3	16,9	2	6	12	190
K0776.06040	12	6	40	46	60	3	16,9	2	6	12	190
K0776.06050	12	6	50	56	70	3	16,9	2	6	12	190
K0776.08025	16	8	25	31	46	4	16,9	2	8	21	270
K0776.08040	16	8	40	46	61	4	16,9	2	8	21	270
K0776.08050	16	8	50	56	71	4	16,9	2	8	21	270

Locking pins with axial lock



Material:
Steel.

Version:
galvanized.

Sample order:
K0772.1206016

Note:
Locking pins are used for quick and easy fixating and joining of parts and workpieces.

Shearing force double-shear (F) = S · τ aB max.

Assembly:
In the counterpart, observe the length X as an inlet guide.

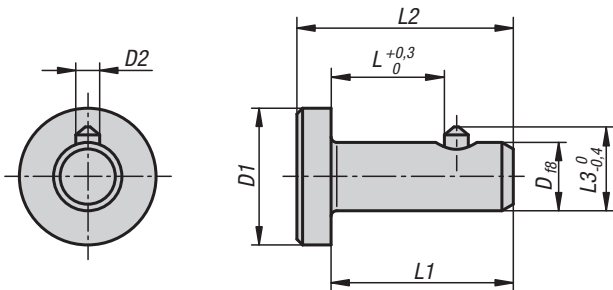

Chamfer for counterpart Xmin. x45°

Example of use

assembly hole

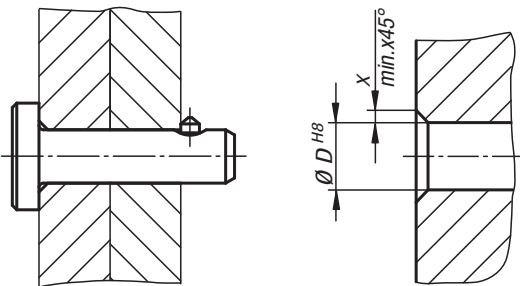

KIPP Locking pins with axial lock

Order No.	D	D1	D2	X	L	L1	L2	L3	Shearing force double shear max.kN
K0772.1206010	6	12	2,1	1,1	10	16	19	7,4	12
K0772.1206012	6	12	2,1	1,1	12	18	21	7,4	12
K0772.1206016	6	12	2,1	1,1	16	22	25	7,4	12
K0772.1206020	6	12	2,1	1,1	20	26	29	7,4	12
K0772.1608012	8	16	2,1	1,1	12	18	22	9,4	22
K0772.1608016	8	16	2,1	1,1	16	22	26	9,4	22
K0772.1608020	8	16	2,1	1,1	20	26	30	9,4	22
K0772.1608025	8	16	2,1	1,1	25	31	35	9,4	22
K0772.2010012	10	20	2,8	1,2	12	20	24	11,8	35
K0772.2010016	10	20	2,8	1,2	16	24	28	11,8	35
K0772.2010020	10	20	2,8	1,2	20	28	32	11,8	35
K0772.2010025	10	20	2,8	1,2	25	33	37	11,8	35
K0772.2412016	12	24	2,8	1,2	16	24	29	13,8	51
K0772.2412020	12	24	2,8	1,2	20	28	33	13,8	51
K0772.2412025	12	24	2,8	1,2	25	33	38	13,8	51
K0772.2412030	12	24	2,8	1,2	30	38	43	13,8	51



Ball lock pins

with T-grip, self-locking

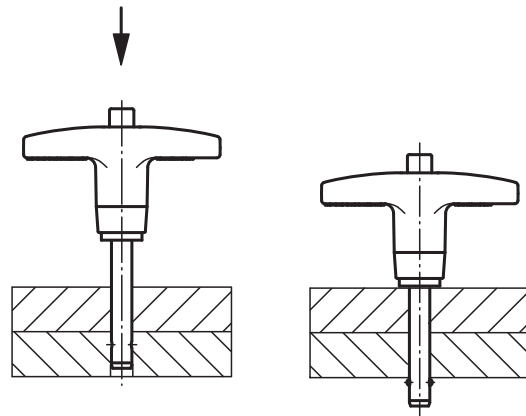
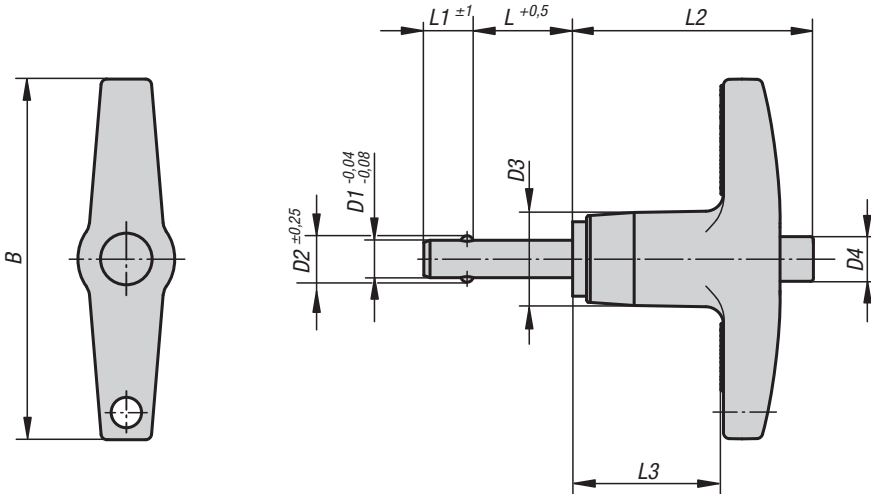

Material:

Pin stainless steel 1.4542.
Grip die-cast aluminium EN-AC 46000.
Push button aluminium EN-AW 2024 T4.
Balls stainless steel 1.4125.
Compression spring stainless steel.

Version:

All stainless steel parts passivated.
Pin hardened to min. 40 HRC.
Grip black anodised.
Push button blue anodised.
Balls hardened to 58 +4 HRC.

Sample order:

K0366.24605030
(include length L e.g. 030 for L = 30 mm.)

Note:

Ball lock pins are used for quick and easy fastening and joining of parts and workpieces. The two balls are disengaged by pressing the push button and the pin can be slipped into holes in the workpieces. Release the button to lock the balls and secure the connection. The ball lock pins can be provided with a retaining cable if required.

The hardened, high-tensile stainless steel pin permits extreme loads with low wear.

Shearing force double shear (F) = S · τ aB max.

Accessories:

Safety spiral cable K0367.10200
Retaining cable with loop K0367.
Key ring K0367.15/19/23
Bushing for ball lock pins K0724....

KIPP Ball lock pins with T-grip, self-locking

Order No.	B	D1	D2	D3	D4	L	L1	L2	L3	Receiving hole H11	Shearing force double shear max.kN
K0366.24605***	46	5	5,54	11,9	5,8	10/15/20/25/30/35/40/50/60/70	6	30,7	19,3	5	24,40
K0366.24606***	46	6	6,99	11,9	5,8	10/15/20/25/30/35/40/50/60/70/80	7	30,7	19,3	6	35,64
K0366.24608***	46	8	9,42	11,9	5,8	10/15/20/25/30/35/40/50/60/70/80	8	30,7	19,3	8	63,80
K0366.25110***	50,8	10	11,86	14,2	7,4	15/20/25/30/35/40/50/60/70/80/90/100	9	34,8	22,1	10	100,10
K0366.25812***	57,2	12	14,45	18,3	10,7	20/25/30/35/40/50/60/70/80/90/100	10	40,6	25,4	12	144,06
K0366.27816***	78	16	19	23,9	13,7	25/30/35/40/50/60/70/80/90/100	14	45	28,2	16	257,18

Ball lock pins

with L-grip, self-locking

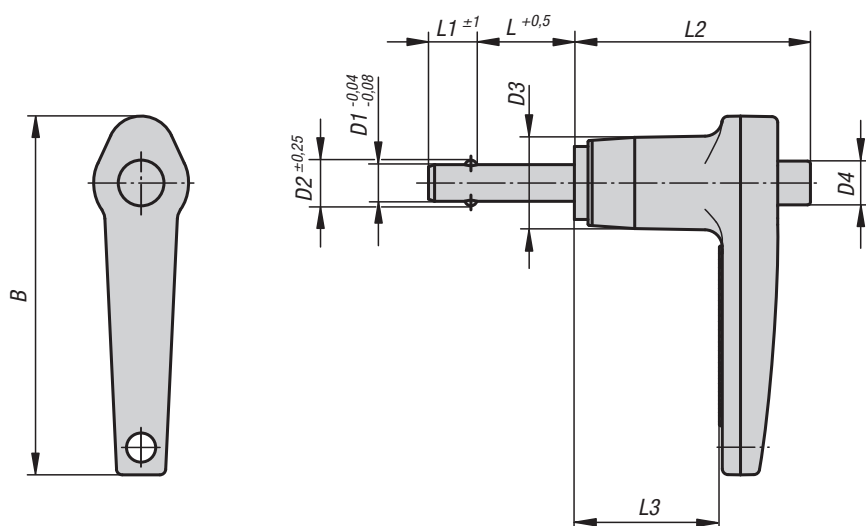

Material:

Pin stainless steel 1.4542.
 Grip die-cast aluminium EN-AC 46000.
 Push button aluminium EN-AW 2024 T4.
 Balls stainless steel 1.4125.
 Compression spring stainless steel.

Version:

All stainless steel parts passivated.
 Pin hardened to min. 40 HRC.
 Grip black anodized.
 Push button blue anodized.
 Balls hardened to 58 +4 HRC.

Sample order:

K0642.14405030
 (include length L e.g. 030 for L = 30 mm)

Note:

Ball lock pins are used for quick and easy fastening and joining of parts and workpieces. The two balls are disengaged by pressing the push button and the pin can be slipped into holes in the workpieces. Release the button to lock the balls and secure the connection. The ball lock pins can be provided with a retaining cable if required.

The hardened, high-tensile stainless steel pin permits extreme loads with low wear.

Shearing force double shear (F) = S · τ aB max.

Accessories:

Safety spiral cable K0367.10200
 Retaining cable with loop K0367.
 Key ring K0367.15/19/23
 Bushing for ball lock pins K0724....

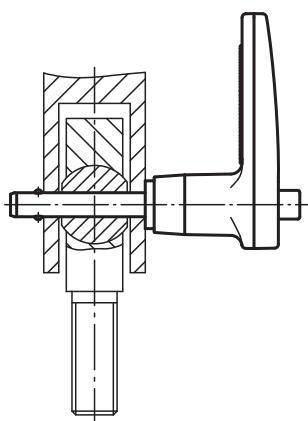

KIPP Ball lock pins with L-grip, self-locking

Order No.	B	D1	D2	D3	D4	L	L1	L2	L3	Receiving hole H11	Shearing force double shear max.kN
K0642.14405***	46,7	5	5,54	11,9	5,8	10/15/20/25/30/35/40/50/60/70	6	30,7	19,3	5	24,40
K0642.14406***	46,7	6	6,99	11,9	5,8	10/15/20/25/30/35/40/50/60/70/80	7	30,7	19,3	6	35,64
K0642.14408***	46,7	8	9,42	11,9	5,8	10/15/20/25/30/35/40/50/60/70/80	8	30,7	19,3	8	63,80
K0642.15110***	54,1	10	11,86	14,2	7,4	15/20/25/30/35/40/50/60/70/80/90/100	9	34,8	22,1	10	100,10
K0642.15712***	60,2	12	14,45	18,3	10,7	20/25/30/35/40/50/60/70/80/90/100	10	40,6	25,4	12	144,06
K0642.16816***	68,3	16	19	23,9	13,7	25/30/35/40/50/60/70/80/90/100	14	45	28,2	16	257,18

Safety spiral cables

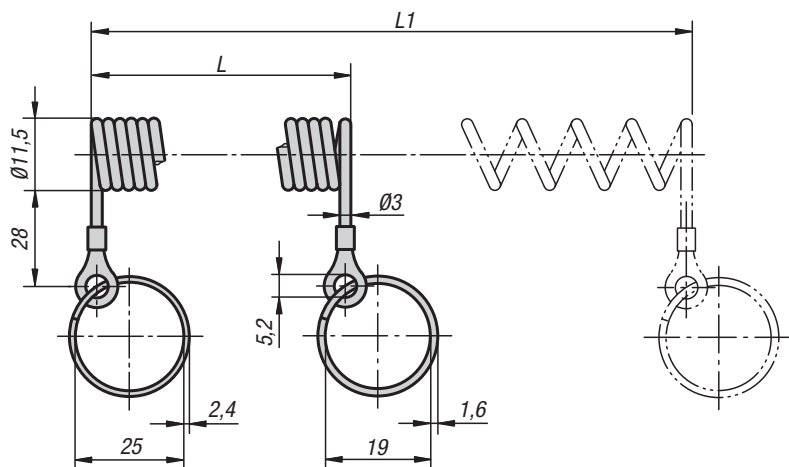

Material:
Spiral cable PUR.
Eye galvanized copper.
Key ring steel.

Version:
Spiral cable, black.
Eye, galvanized.
Key ring, chromium-plated.

Sample order:
K0367.10200

Note:
Elastic spiral cable to secure equipment parts. Very good reset force, robust and wear-resistant.

KIPP Safety spiral cable

Order No.	L	L1
K0367.10100	100	500
K0367.10200	200	1000

K0367

Retaining cables

with loop

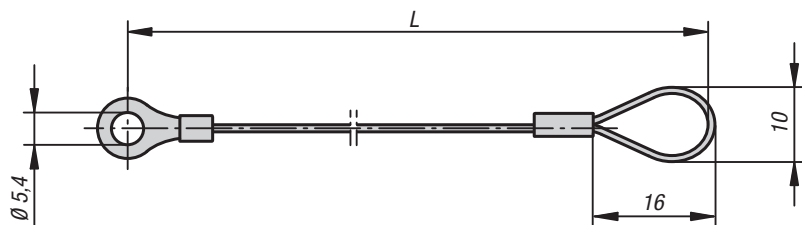

Material:
Cable stainless steel.
Clamp and crimp terminal aluminium.

Version:
Cable plastic coated.

Sample order:
K0367.0200

Note:
With the retaining cable and key ring (K0367) the ball lock pins (K0363, K0364, K0641, K0366, K0642, K0790, K0791) can be secured so that they cannot be lost. An M5 screw is used to secure the retaining cable. Application temperature: +80 °C.

KIPP Restraining cables with loop

Order No.	L
K0367.0150	150
K0367.0200	200
K0367.0300	300

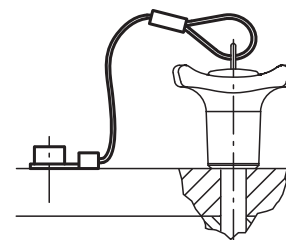

Key rings

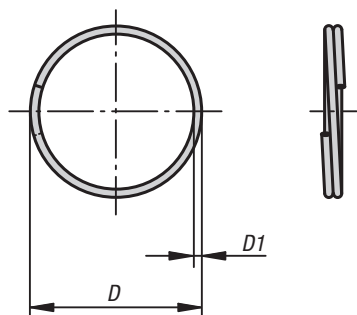

Material:
Stainless steel 1.4310.

Version:
Bright.

Sample order:
K0367.23

Note:
Suitable for retaining cable with loop K0367, ball lock pins K0363, K0364, K0641, K0366, K0642, K0790, K0791 locking pins K0365 and indexing plungers K0342, K0635, K0636.

KIPP Key rings

Order No.	D	D1
K0367.15	15	1
K0367.19	19	1
K0367.23	23	1,2
K0367.28	28	1,7

Notes

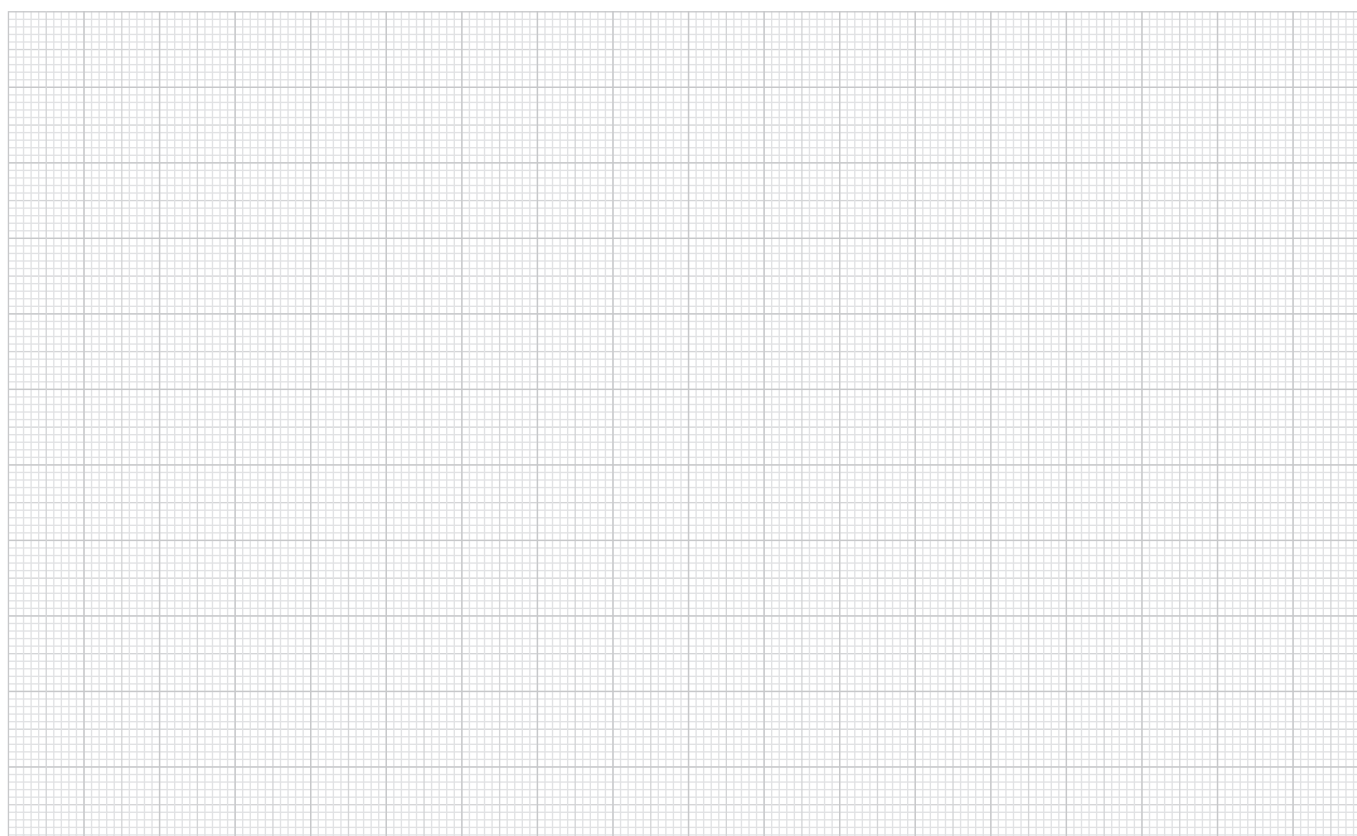

Bushing for ball lock pins

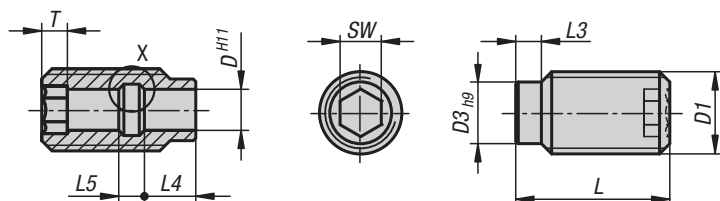

view "X"

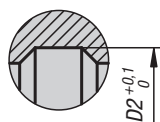
**Material:**

Stainless steel 1.4305.

Version:

Steel parts bright.

Sample order:

K0724.11224

Note:

Bushing for ball lock pins are ideal for the easy and quick positioning of ball lock pins and locking pins.

Advantages:

- The bushing is centred by the centring collar.
- easy and reliable screwing in.
- can be screwed into various materials.
- usable both sides

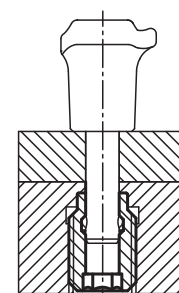

KIPP Bushing for ball lock pins

Order No.	D	D1	D2	D3	L	L3	L4	L5	SW	T
K0724.10512	5	M12	6	9	25	4	7	3	5	4
K0724.10616	6	M16	7,5	12	30	5	10	5	6	5
K0724.10816	8	M16	10	12	30	5	10	5	8	5
K0724.11024	10	M24	13	18	35	6	8	7	10	6
K0724.11224	12	M24	15	18	35	6	8	7	12	6
K0724.11630	16	M30	20	24	40	8	11	9	16	7

Bushing for ball lock pins

with LONG-LOK thread lock

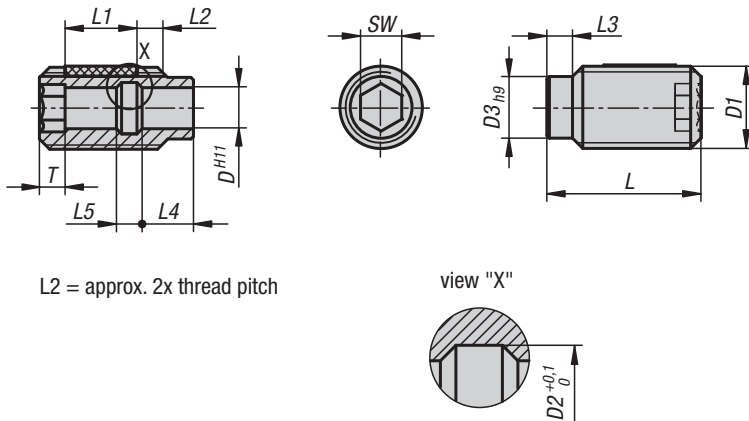

L2 = approx. 2x thread pitch

Material:
Stainless steel 1.4305

LONG-LOK thread lock nylon.

Version:
Steel parts bright.

Sample order:
K0724.112241

Note:
Bushing for ball lock pins are ideal for the easy and quick positioning of ball lock pins and locking pins.

- Advantages:**
- the bushing is centred by the centring collar.
 - easy and reliable screwing in.
 - can be screwed into various materials.
 - usable both sides
 - the LONG-LOK thread lock allows the depth to be exactly matched to existing components, no locknut is required.

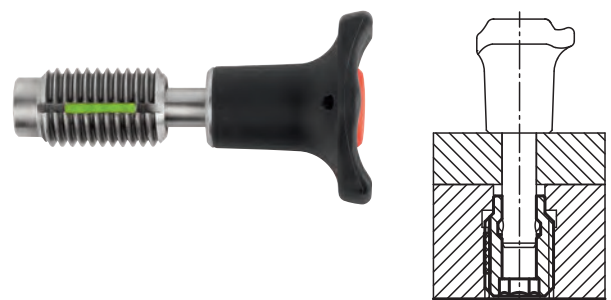

KIPP Bushing for ball locking pins, with LONG-LOK thread lock

Order No.	D	D1	D2	D3	L	L1	L3	L4	L5	SW	T
K0724.105121	5	M12	6	9	25	10	4	7	3	5	4
K0724.106161	6	M16	7,5	12	30	14	5	10	5	6	5
K0724.108161	8	M16	10	12	30	14	5	10	5	8	5
K0724.110241	10	M24	13	18	35	14	6	8	7	10	6
K0724.112241	12	M24	15	18	35	14	6	8	7	12	6
K0724.116301	16	M30	20	24	40	14	8	11	9	16	7

