

535-R-L



Ayak Tipi: Yatay Tabanlı, Döküm Gövdeli, Çandan Kollu
Body Mounting Base: Horizontal Base, Casted Body With Side Mounted Handle

Ürün özellikleri ;

Ağır iş uygulamalarında kullanıma uygun mukavemetli ürünlerdir. Gövde mukavemetli GGG-60 döküm malzemeden üretilmiş ve siyah elektro statik toz boya ile boyanmıştır.

Mil, yüksek aşınma direnci ve korozyon direnci için sert krom kaplı malzemeden üretilmiştir. Mekanizma parçaları çelik malzemeden üretilmiş ve korozyon direnci için galvaniz kaplama yapılmıştır.

Product Features ;

The products are strong and suited for heavy duty applications.

The body is made of strong GGG-60 casting and coated with black electrostatic powder paint. The rod is made of hard chrome plated steel for high wear and corrosion resistance and the mechanism parts are made of galvanized steel for corrosion resistance.

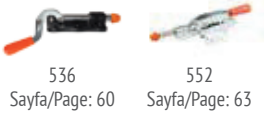

536
Sayfa/Page: 60

552
Sayfa/Page: 63

MODEL NO	F1 (N)	F3 (N)	Fi	BASKI VİDASI (SQUEEZE SCREW)	STROK	AĞIRLIK (WEIGHT) (gr)
			VERİM (YIELD) (F1:Fi)			
535 - 3 (Ø 12) - R	1500	1700	16:1	M8X50	43	630
535 - 3 (Ø 12) - L	1500	1700	16:1	M8X50	43	630
535 - 4 (Ø 16) - R	4500	4700	23:1	M10X70	52	1030
535 - 4 (Ø 16) - L	4500	4700	23:1	M10X70	52	1030

F1 : BASKI KUVVETİ (EXERTING FORCE) , F3 : TUTMA KAPASİTESİ (HOLDING CAPACITY)
Fi : UYGULAMA KUVVETİ (APPLIED FORCE)

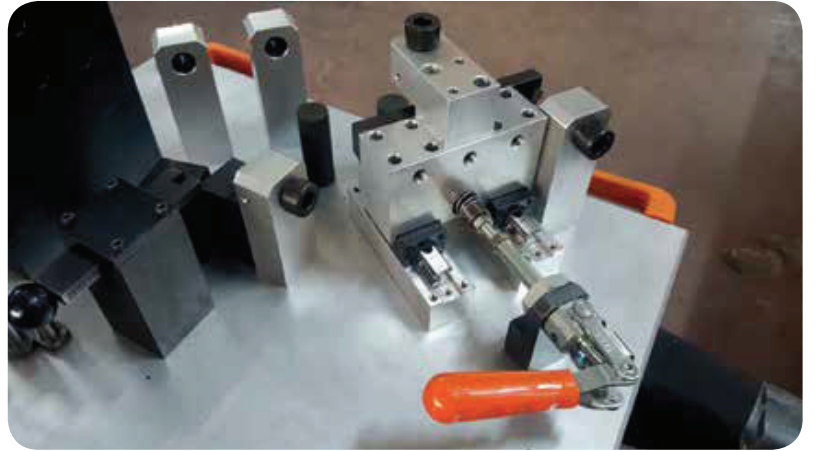
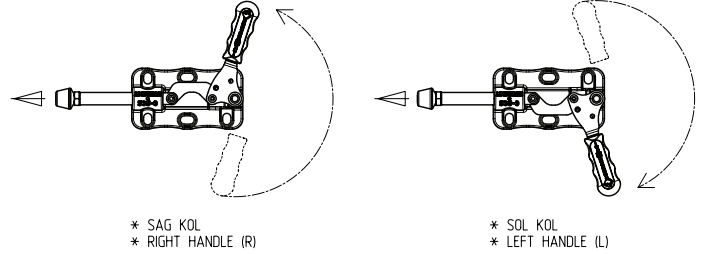
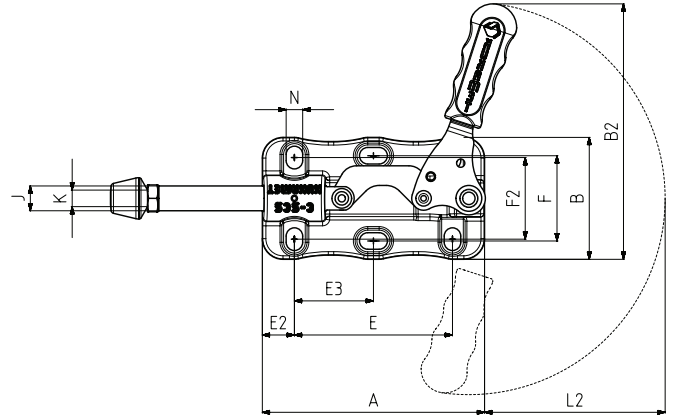
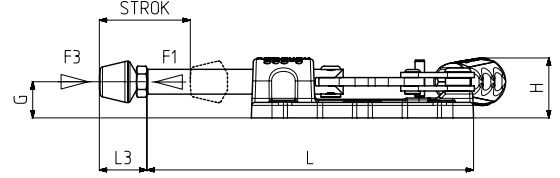

MODEL NO	A	B	B2	E ~	E2 ~	E3 ~	F ~	F2 ~	G	H	J	K	L	L2	L3 Min	L3 Max	N
535 - 3 (Ø 12) - R	107	59	124	76,5	15,5	35,5 - 41	36,5 - 42,5	41	17,5	30	12	M8	156	87	24	58	8 x 11
535 - 3 (Ø 12) - L	107	59	124	76,5	15,5	35,5 - 41	36,5 - 42,5	41	17,5	30	12	M8	156	87	24	58	8 x 11
535 - 4 (Ø 16) - R	130	71	157	74,5 - 75,5	18	35 - 41	41,5 - 53	41,5	20,5	35	16	M10	188	113	32	81	9 x 15
535 - 4 (Ø 16) - L	130	71	157	74,5 - 75,5	18	35 - 41	41,5 - 53	41,5	20,5	35	16	M10	188	113	32	81	9 x 15