

MODEL NO	F1 (N)	F3 (N)	Fi VERİM (YIELD) (F1:Fi)	BASKI VİDASI (SQUEEZE SCREW)	STROK	AĞIRLIK (WEIGHT) (gr)
521 - 3 (Ø 12)	2500	2960	16:1	M8X50	38	390
521 - 3 (Ø 14)	2500	3200	16:1	M8X50	38	405
521 - 4 (Ø 16)	4500	6650	23:1	M10X70	47	810
521 - 4 (Ø 18)	4500	7200	23:1	M10X70	47	825
521 - 5 (Ø 20)	7500	15000	30:1	M12X80	55	1425

F1 : BASKI KUVVETİ ( EXERTING FORCE ), F3 : TUTMA KAPASİTESİ ( HOLDING CAPACITY ), Fi : UYGULAMA KUVVETİ ( APPLIED FORCE )

521



**Ayak Tipi: Yatay Tabanlı, Kaynaklı**  
Body Mounting Base: Horizontal, With Welding



531

Sayfa/Page: 55

532

Sayfa/Page: 56

534

Sayfa/Page: 58

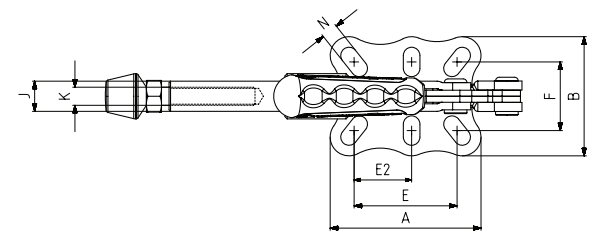
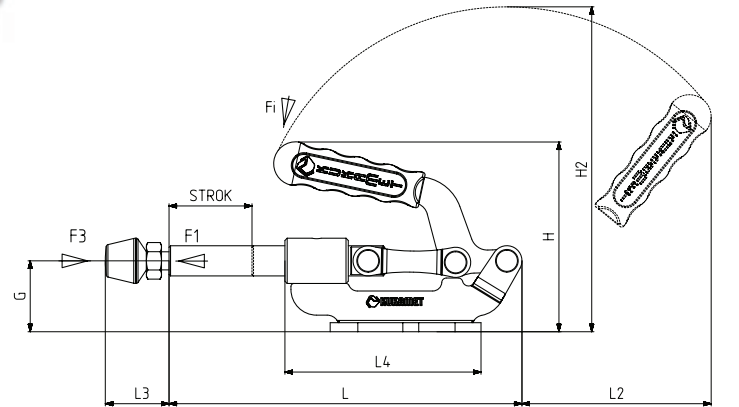

MODEL NO : 521-5

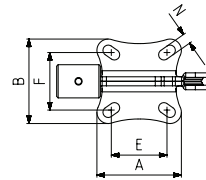

MODEL NO : 521-3

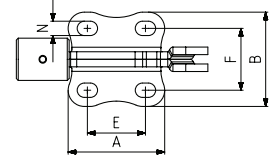

MODEL NO : 521-4

MODEL NO	A	B	E ~	E2 ~	F ~	G	H	H2	J	K	L	L2	L3 Min	L3 Max	L4	N
521 - 3 (Ø 12)	56	56	32,5 - 41		35 - 41	32	88	142	12	M8	154	85	24	58	83	7 x 12
521 - 3 (Ø 14)	56	56	32,5 - 41		35 - 41	32	88	142	14	M8	154	85	24	58	83	7 x 12
521 - 4 (Ø 16)	64	62	34,5 - 42,5		41	40	107	179	16	M10	186	105	32	81	98	9,5 x 13,5
521 - 4 (Ø 18)	64	62	34,5 - 42,5		41	40	107	179	18	M10	186	105	32	81	98	9,5 x 13,5
521 - 5 (Ø 20)	100	79	61,5 - 75	34,75 - 41,5	37 - 54	47	125	216	20	M12	234	125	39	94	130	11 x 22