

CODICE - CODE		descrizione description	DIMENSIONI PRINCIPALI - MAIN DIMENSIONS							CARICO STATICO STATIC LOAD NEWTON
standard standard	antiscivolo antislip		A	B	D	⬡	F	H	H1	
9000	9001	M8X25	16	25	Ø40	4	M8	41	44	5000
9010	9011	M8X50	16	50	Ø40	4	M8	66	69	5000
9020	9021	M10X25	16	25	Ø40	5	M10	41	44	5000
9030	9031	M10X50	16	50	Ø40	5	M10	66	69	5000
9040	9041	M8X25	20	25	Ø50	4	M8	45	48	6000
9050	9051	M8X50	20	50	Ø50	4	M8	70	73	6000
9060	9061	M10X25	20	25	Ø50	5	M10	45	48	6000
9070	9071	M10X50	20	50	Ø50	5	M10	70	73	6000

Confezione:

- per articoli con base Ø 40 mm: 200 pezzi
- per articoli con base Ø 50 mm: 150 pezzi

Set Box:

- Products Ø 40 mm base: 200 pieces
- Products Ø 50 mm base: 150 pieces

- Materiale base: poliammide rinforzato con sfera di vetro. A richiesta disponibile con gomma antiscivolo NBR 70 shore (codice standard = senza gomma). Materiale stelo: acciaio inox AISI 304 (a richiesta AISI 316). Su richiesta l'elemento di livellamento viene fornito con dado in acciaio.
- I valori dei carichi sopra riportati sono calcolati in condizioni statiche alla metà della lunghezza dello stelo filettato. Qualora s'intendesse utilizzare i supporti in presenza di vibrazioni o carichi in movimento, tali valori dovranno essere adeguatamente ridotti. Per ulteriori chiarimenti consultare il nostro ufficio tecnico. Ogni nostra responsabilità decade in caso di manomissioni o modifiche dei componenti.
- Base in black polyamide material, reinforced by sphere glass. On request non-skid plate in NBR rubber 70 shore is available (Standard code = without rubber). Stainless steel screw in 1.4301 (1.4401 on specific request). The leveling mount could be supplied, on request, with steel nut.
- Load values above mentioned have to be considered referring to static conditions calculated at the half of the screw length. In conditions of vibrations or in presence of dynamic loads these values should be reduced. For further information consult our technical office. We cannot accept responsibility for mounts that have been tampered or modified.

Caratteristiche: BASE Ø 40, STELO SNODATO 30°

Features: BASE Ø 40, 30° ARTICULATED STEM

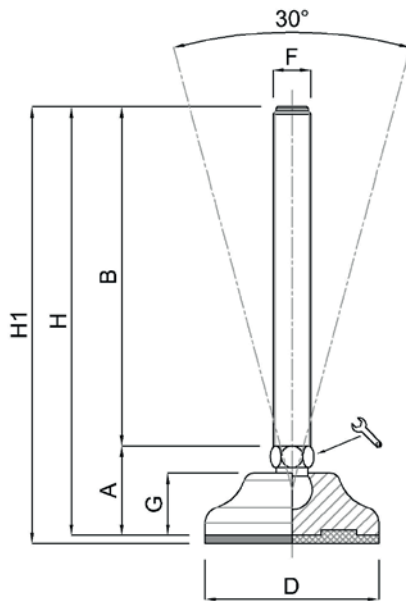

CODICE - CODE		descrizione description	DIMENSIONI PRINCIPALI - MAIN DIMENSIONS								CARICO STATICO STATIC LOAD NEWTON
standard standard	antiscivolo antislip		A	B	D		F	G	H	H1	
10000/6	10001/6	M6X25	27	25	Ø 40	12	M6	16	52	55	5000
10002/6	10003/6	M6X50	27	50	Ø 40	12	M6	16	77	80	5000
10004/6	10005/6	M6X75	27	75	Ø 40	12	M6	16	102	105	5000
10000	10001	M8X25	27	25	Ø 40	12	M8	16	52	55	10000
10002	10003	M8X50	27	50	Ø 40	12	M8	16	77	80	10000
10004	10005	M8X75	27	75	Ø 40	12	M8	16	102	105	10000
10006	10007	M8X100	27	100	Ø 40	12	M8	16	127	130	10000
10008	10009	M10X25	27	25	Ø 40	12	M10	16	52	55	10000
10010	10011	M10X50	27	50	Ø 40	12	M10	16	77	80	10000
10012	10013	M10X75	27	75	Ø 40	12	M10	16	102	105	10000
10014	10015	M10X100	27	100	Ø 40	12	M10	16	127	130	10000
10016	10017	M10X125	27	125	Ø 40	12	M10	16	152	155	10000
10008/12	10009/12	M12X25	27	25	Ø 40	12	M12	16	52	55	10000
10010/12	10011/12	M12X50	27	50	Ø 40	12	M12	16	77	80	10000
10012/12	10013/12	M12X75	27	75	Ø 40	12	M12	16	102	105	10000
10014/12	10015/12	M12X100	27	100	Ø 40	12	M12	16	127	130	10000
10016/12	10017/12	M12X125	27	125	Ø 40	12	M12	16	152	155	10000
10016/12x150	10017/12x150	M12X150	27	150	Ø 40	12	M12	16	177	180	10000

• Materiale base: poliammide rinforzato con sfera di vetro. A richiesta disponibile con gomma antiscivolo NBR 70 shore (codice standard = senza gomma). Materiale stelo: acciaio inox AISI 304 (a richiesta AISI 316). Su richiesta l'elemento di livellamento viene fornito con dado in acciaio.

• I valori dei carichi sopra riportati sono calcolati in condizioni statiche alla metà della lunghezza dello stelo filettato. Qualora s'intendesse utilizzare i supporti in presenza di vibrazioni o carichi in movimento, tali valori dovranno essere adeguatamente ridotti. Per ulteriori chiarimenti consultare il nostro ufficio tecnico. Ogni nostra responsabilità decade in caso di manomissioni o modifiche dei componenti.

• Base in black polyamide material, reinforced by sphere glass. On request non-skid plate in NBR rubber 70 shore is available (Standard code = without rubber). Stainless steel screw in 1.4301 (1.4401 on specific request). The leveling mount could be supplied, on request, with steel nut.

• Load values above mentioned have to be considered referring to static conditions calculated at the half of the screw length. In conditions of vibrations or in presence of dynamic loads these values should be reduced. For further information consult our technical office. We cannot accept responsibility for mounts that have been tampered or modified.

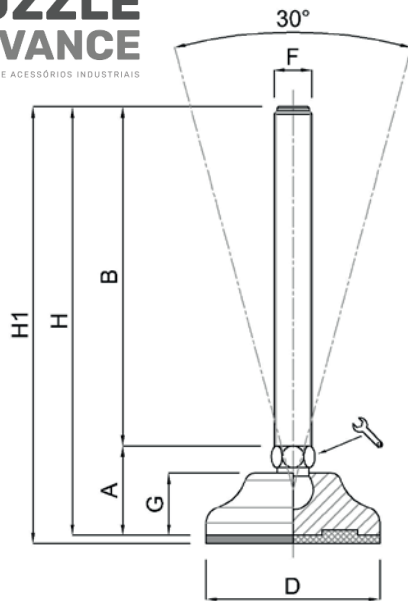

CODICE - CODE		descrizione description	DIMENSIONI PRINCIPALI - MAIN DIMENSIONS								CARICO STATICO STATIC LOAD NEWTON
standard standard	antiscivolo antislip		A	B	D		F	G	H	H1	
10018	10019	M10X25	31	25	Ø 50	14	M10	20	56	59	11000
10020	10021	M10X50	31	50	Ø 50	14	M10	20	81	84	11000
10022	10023	M10X75	31	75	Ø 50	14	M10	20	106	109	11000
10024	10025	M10X100	31	100	Ø 50	14	M10	20	131	134	11000
10026	10027	M10X125	31	125	Ø 50	14	M10	20	156	159	11000
10028	10029	M12X25	31	25	Ø 50	14	M12	20	56	59	11000
10030	10031	M12X50	31	50	Ø 50	14	M12	20	81	84	11000
10032	10033	M12X75	31	75	Ø 50	14	M12	20	106	109	11000
10034	10035	M12X100	31	100	Ø 50	14	M12	20	131	134	11000
10036	10037	M12X125	31	125	Ø 50	14	M12	20	156	159	11000
10036/150	10037/150	M12X150	31	150	Ø 50	14	M12	20	181	184	11000
10038	10039	M14X25	31	25	Ø 50	14	M14	20	56	59	11000
10040	10041	M14X50	31	50	Ø 50	14	M14	20	81	84	11000
10042	10043	M14X75	31	75	Ø 50	14	M14	20	106	109	11000
10044	10045	M14X100	31	100	Ø 50	14	M14	20	131	134	11000
10046	10047	M14X125	31	125	Ø 50	14	M14	20	156	159	11000
10040/16	10041/16	M16X50	35	50	Ø 50	13*	M16	20	85	88	11000
10042/16	10043/16	M16X75	35	75	Ø 50	13*	M16	20	110	113	11000
10044/16	10045/16	M16X100	35	100	Ø 50	13*	M16	20	135	138	11000
10046/16	10047/16	M16X125	35	125	Ø 50	13*	M16	20	160	163	11000
10048/16	10049/16	M16X150	35	150	Ø 50	13*	M16	20	185	188	11000

* Chiave ottenuta da barra tonda
Wrench from round bar

- Materiale base: poliammide rinforzato con sfera di vetro. A richiesta disponibile con gomma antiscivolo NBR 70 shore (codice standard = senza gomma). Materiale stelo: acciaio inox AISI 304 (a richiesta AISI 316). Su richiesta l'elemento di livellamento viene fornito con dado di acciaio.
- I valori dei carichi sopra riportati sono calcolati in condizioni statiche alla metà della lunghezza dello stelo filettato. Qualora s'intendesse utilizzare i supporti in presenza di vibrazioni o carichi in movimento, tali valori dovranno essere adeguatamente ridotti. Per ulteriori chiarimenti consultare il nostro ufficio tecnico. Ogni nostra responsabilità decade in caso di manomissioni o modifiche dei componenti.
- Base in black polyamide material, reinforced by sphere glass. On request non-skid plate in NBR rubber 70 shore is available (Standard code = without rubber). Stainless steel screw in 1.4301 (1.4401 on specific request). The leveling mount could be supplied, on request, with steel nut.
- Load values above mentioned have to be considered referring to static conditions calculated at the half of the screw length. In conditions of vibrations or in presence of dynamic loads these values should be reduced. For further information consult our technical office. We cannot accept responsibility for mounts that have been tampered or modified.

Piede in Polyamide & Inox

PLASTICA

Martin
Levelling Components

PLASTICA

Caratteristiche: BASE Ø 65, STELO SNODATO 30°

Features: BASE Ø 65, 30° ARTICULATED STEM

PUZZLE
ADVANCE
COMÉRCIO DE ACESSÓRIOS INDUSTRIAIS

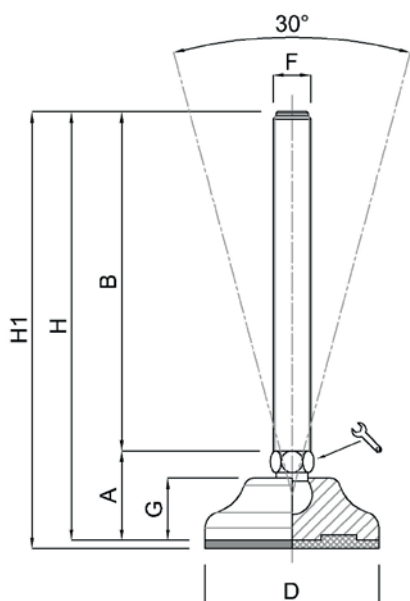

CODICE - CODE		descrizione description	DIMENSIONI PRINCIPALI - MAIN DIMENSIONS								CARICO STATICO STATIC LOAD NEWTON
standard standard	antiscivolo antislip		A	B	D		F	G	H	H1	
10048/10	10049/10	M10X50	33	50	Ø 65	14	M10	23	83	86	11000
10050/10	10051/10	M10X75	33	75	Ø 65	14	M10	23	108	111	11000
10052/10	10053/10	M10X100	33	100	Ø 65	14	M10	23	133	136	11000
10054/10	10055/10	M10X125	33	125	Ø 65	14	M10	23	158	161	11000
10048/12	10049/12	M12X50	33	50	Ø 65	14	M12	23	83	86	11000
10050/12	10051/12	M12X75	33	75	Ø 65	14	M12	23	108	111	11000
10052/12	10053/12	M12X100	33	100	Ø 65	14	M12	23	133	136	11000
10054/12	10055/12	M12X125	33	125	Ø 65	14	M12	23	158	161	11000
10056/12	10057/12	M12X150	33	150	Ø 65	14	M12	23	183	186	11000
10048	10049	M14X50	33	50	Ø 65	14	M14	23	83	86	15000
10050	10051	M14X75	33	75	Ø 65	14	M14	23	108	111	15000
10052	10053	M14X100	33	100	Ø 65	14	M14	23	133	136	15000
10054	10055	M14X125	33	125	Ø 65	14	M14	23	158	161	15000
10056	10057	M14X150	33	150	Ø 65	14	M14	23	183	186	15000
10058	10059	M14X175	33	175	Ø 65	14	M14	23	208	211	15000
10060	10061	M16X50	38	50	Ø 65	13*	M16	23	88	91	15000
10062	10063	M16X75	38	75	Ø 65	13*	M16	23	113	116	15000
10064	10065	M16X100	38	100	Ø 65	13*	M16	23	138	141	15000
10066	10067	M16X125	38	125	Ø 65	13*	M16	23	163	166	15000
10068	10069	M16X150	38	150	Ø 65	13*	M16	23	188	191	15000
10070	10071	M16X175	38	175	Ø 65	13*	M16	23	213	216	15000
10072	10073	M16X200	38	200	Ø 65	13*	M16	23	238	241	15000
10060/20	10061/20	M20X50	38	50	Ø 65	17*	M20	23	88	91	15000
10062/20	10063/20	M20X75	38	75	Ø 65	17*	M20	23	113	116	15000
10064/20	10065/20	M20X100	38	100	Ø 65	17*	M20	23	138	141	15000
10066/20	10067/20	M20X125	38	125	Ø 65	17*	M20	23	163	166	15000
10068/20	10069/20	M20X150	38	150	Ø 65	17*	M20	23	188	191	15000
10070/20	10071/20	M20X175	38	175	Ø 65	17*	M20	23	213	216	15000
10072/20	10073/20	M20X200	38	200	Ø 65	17*	M20	23	238	241	15000

* Chiave ottenuta da barra tonda
Wrench from round bar

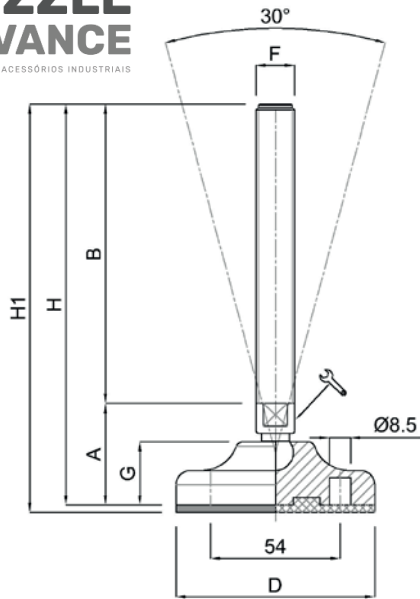

CODICE - CODE		descrizione description	DIMENSIONI PRINCIPALI - MAIN DIMENSIONS								CARICO STATICO STATIC LOAD NEWTON
standard standard	antiscivolo antislip		A	B	D		F	G	H	H1	
10074/10	10075/10	M10X50	38	50	Ø 83	14	M10	27	88	91	15000
10076/10	10077/10	M10X75	38	75	Ø 83	14	M10	27	113	116	15000
10078/10	10079/10	M10X100	38	100	Ø 83	14	M10	27	138	141	15000
10080/10	10081/10	M10X125	38	125	Ø 83	14	M10	27	163	166	15000
10074/12	10075/12	M12X50	38	50	Ø 83	14	M12	27	88	91	15000
10076/12	10077/12	M12X75	38	75	Ø 83	14	M12	27	113	116	15000
10078/12	10079/12	M12X100	38	100	Ø 83	14	M12	27	138	141	15000
10080/12	10081/12	M12X125	38	125	Ø 83	14	M12	27	163	166	15000
10082/12	10083/12	M12X150	38	150	Ø 83	14	M12	27	188	191	15000
10074/14	10075/14	M14X50	38	50	Ø 83	14	M14	27	88	91	20000
10076/14	10077/14	M14X75	38	75	Ø 83	14	M14	27	113	116	20000
10078/14	10079/14	M14X100	38	100	Ø 83	14	M14	27	138	141	20000
10080/14	10081/14	M14X125	38	125	Ø 83	14	M14	27	163	166	20000
10082/14	10083/14	M14X150	38	150	Ø 83	14	M14	27	188	191	20000
10084/14	10085/14	M14X175	38	175	Ø 83	14	M14	27	213	216	20000
10074	10075	M16X50	42	50	Ø 83	13*	M16	27	92	95	20000
10076	10077	M16X75	42	75	Ø 83	13*	M16	27	117	120	20000
10078	10079	M16X100	42	100	Ø 83	13*	M16	27	142	145	20000
10080	10081	M16X125	42	125	Ø 83	13*	M16	27	167	170	20000
10082	10083	M16X150	42	150	Ø 83	13*	M16	27	192	195	20000
10084	10085	M16X175	42	175	Ø 83	13*	M16	27	217	220	20000
10086	10087	M16X200	42	200	Ø 83	13*	M16	27	242	245	20000
10088	10089	M20X75	42	75	Ø 83	17*	M20	27	117	120	20000
10090	10091	M20X100	42	100	Ø 83	17*	M20	27	142	145	20000
10092	10093	M20X125	42	125	Ø 83	17*	M20	27	167	170	20000
10094	10095	M20X150	42	150	Ø 83	17*	M20	27	192	195	20000
10096	10097	M20X175	42	175	Ø 83	17*	M20	27	217	220	20000
10098	10099	M20X200	42	200	Ø 83	17*	M20	27	242	245	20000
10100	10101	M20X225	42	225	Ø 83	17*	M20	27	267	270	20000

* Chiave ottenuta da barra tonda
Wrench from round bar

Piede in Polyamide & Inox

Caratteristiche: BASE Ø 103, STELO SNODATO 30°

Features: BASE Ø 103, 30° ARTICULATED STEM

PLASTICA

Martin
Levelling Components

PLASTICA

**PUZZLE
ADVANCE**
COMERCIO DE ACESSÓRIOS INDUSTRIAIS

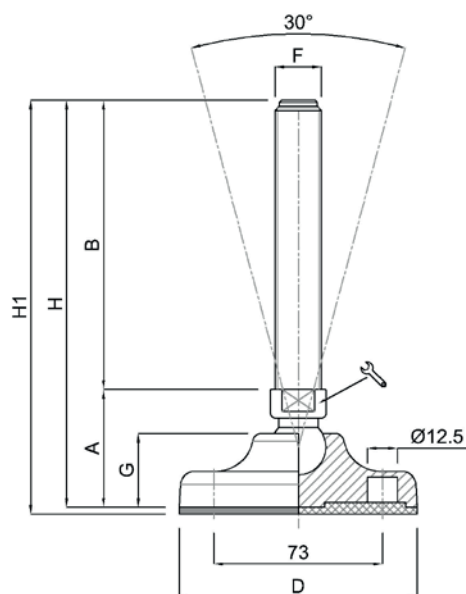

CODICE - CODE		descrizione description	DIMENSIONI PRINCIPALI - MAIN DIMENSIONS								CARICO STATICO STATIC LOAD NEWTON
standard standard	antiscivolo antislip		A	B	D		F	G	H	H1	
10102	10103	M16X50	51	50	Ø 103	20	M16	32	101	104	25000
10104	10105	M16X75	51	75	Ø 103	20	M16	32	126	129	25000
10106	10107	M16X100	51	100	Ø 103	20	M16	32	151	154	25000
10108	10109	M16X125	51	125	Ø 103	20	M16	32	176	179	25000
10110	10111	M16X150	51	150	Ø 103	20	M16	32	201	204	25000
10112	10113	M16X175	51	175	Ø 103	20	M16	32	226	229	25000
10114	10115	M16X200	51	200	Ø 103	20	M16	32	251	254	25000
10116	10117	M16X225	51	225	Ø 103	20	M16	32	276	279	25000
10120	10121	M20X75	51	75	Ø 103	20	M20	32	126	129	25000
10122	10123	M20X100	51	100	Ø 103	20	M20	32	151	154	25000
10124	10125	M20X125	51	125	Ø 103	20	M20	32	176	179	25000
10126	10127	M20X150	51	150	Ø 103	20	M20	32	201	204	25000
10128	10129	M20X175	51	175	Ø 103	20	M20	32	226	229	25000
10130	10131	M20X200	51	200	Ø 103	20	M20	32	251	254	25000
10132	10133	M20X225	51	225	Ø 103	20	M20	32	276	279	25000
10134	10135	M20X250	51	250	Ø 103	20	M20	32	301	304	25000
10138	10139	M24X75	52	75	Ø 103	20	M24	32	127	130	25000
10140	10141	M24X100	52	100	Ø 103	20	M24	32	152	155	25000
10142	10143	M24X125	52	125	Ø 103	20	M24	32	177	180	25000
* 10144	10145	M24X150	52	150	Ø 103	20	M24	32	202	205	25000
* 10146	10147	M24X175	52	175	Ø 103	20	M24	32	227	230	25000
* 10148	10149	M24X200	52	200	Ø 103	20	M24	32	252	255	25000
10150	10151	M24X225	52	225	Ø 103	20	M24	32	277	280	25000
10152	10153	M24X250	52	250	Ø 103	20	M24	32	302	305	25000

* Disponibile con Filettatura a passo fine. Aggiungere "/P2" al codice
Available with Thin pitch thread. Please, add "/P2" to the code

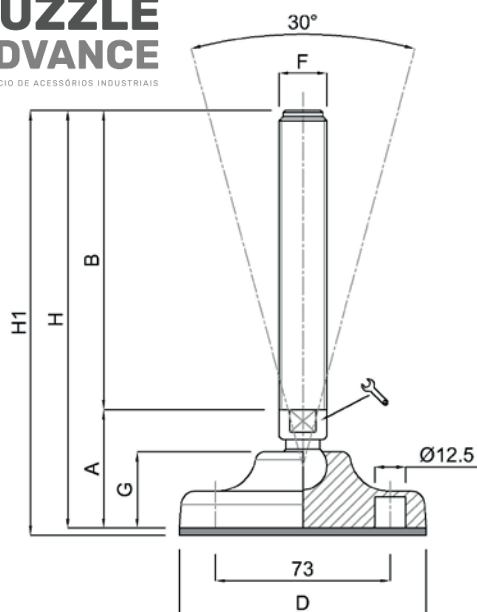

CODICE - CODE		descrizione description	DIMENSIONI PRINCIPALI - MAIN DIMENSIONS								CARICO STATICO STATIC LOAD NEWTON
standard standard	antiscivolo antislip		A	B	D		F	G	H	H1	
10102/15	10103/15	M16X50	48	50	Ø 103	13	M16	32	98	101	20000
10106/15	10107/15	M16X100	48	100	Ø 103	13	M16	32	148	151	20000
10110/15	10111/15	M16X150	48	150	Ø 103	13	M16	32	198	201	20000
10114/15	10115/15	M16X200	48	200	Ø 103	13	M16	32	248	251	20000
10122/20	10123/20	M20X100	50	100	Ø 103	17	M20	32	150	153	20000
10126/20	10127/20	M20X150	50	150	Ø 103	17	M20	32	200	203	20000
10130/20	10131/20	M20X200	50	200	Ø 103	17	M20	32	246	253	20000

• Materiale base: poliammide rinforzato con sfera di vetro. A richiesta disponibile con gomma antiscivolo NBR 70 shore (codice standard = senza gomma). Materiale stelo: acciaio inox AISI 304 (a richiesta AISI 316). Su richiesta l'elemento di livellamento viene fornito con dado in acciaio.

• I valori dei carichi sopra riportati sono calcolati in condizioni statiche alla metà della lunghezza dello stelo filettato. Qualora s'intendesse utilizzare i supporti in presenza di vibrazioni o carichi in movimento, tali valori dovranno essere adeguatamente ridotti. Per ulteriori chiarimenti consultare il nostro ufficio tecnico. Ogni nostra responsabilità decade in caso di manomissioni o modifiche dei componenti.

• Base in black polyamide material, reinforced by sphere glass. On request non-skid plate in NBR rubber 70 shore is available (Standard code = without rubber). Stainless steel screw in 1.4301 (1.4401 on specific request). The leveling mount could be supplied, on request, with steel nut.

• Load values above mentioned have to be considered referring to static conditions calculated at the half of the screw length. In conditions of vibrations or in presence of dynamic loads these values should be reduced. For further information consult our technical office. We cannot accept responsibility for mounts that have been tampered or modified.

Piede in Polyamide & Inox

PLASTICA

Martin
Levelling Components

PLASTICA

Caratteristiche: BASE Ø 123, STELO SNODATO 30°

Features: BASE Ø 123, 30° ARTICULATED STEM

PUZZLE
ADVANCE
COMÉRCIO DE ACESSÓRIOS INDUSTRIAIS

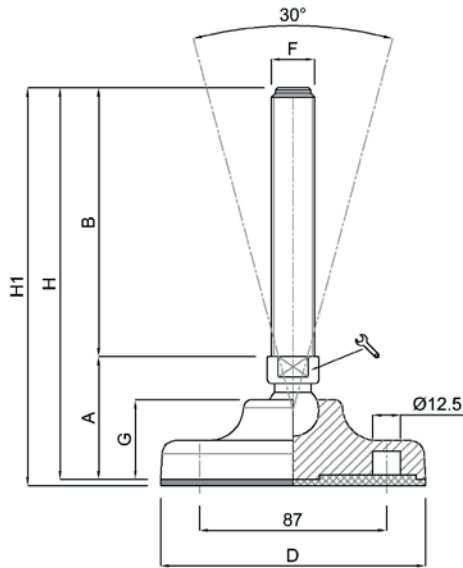

CODICE - CODE		descrizione description	DIMENSIONI PRINCIPALI - MAIN DIMENSIONS								CARICO STATICO STATIC LOAD NEWTON
standard standard	antiscivolo antislip		A	B	D		F	G	H	H1	
10154	10155	M16X50	57	50	Ø 123	20	M16	37	107	110	35000
10156	10157	M16X75	57	75	Ø 123	20	M16	37	132	135	35000
10158	10159	M16X100	57	100	Ø 123	20	M16	37	157	160	35000
10160	10161	M16X125	57	125	Ø 123	20	M16	37	182	185	35000
10162	10163	M16X150	57	150	Ø 123	20	M16	37	207	210	35000
10164	10165	M16X175	57	175	Ø 123	20	M16	37	232	235	35000
10166	10167	M16X200	57	200	Ø 123	20	M16	37	257	260	35000
10168	10169	M16X225	57	225	Ø 123	20	M16	37	282	285	35000
10172	10173	M20X75	57	75	Ø 123	20	M20	37	132	135	35000
10174	10175	M20X100	57	100	Ø 123	20	M20	37	157	160	35000
10176	10177	M20X125	57	125	Ø 123	20	M20	37	182	185	35000
10178	10179	M20X150	57	150	Ø 123	20	M20	37	207	210	35000
10180	10181	M20X175	57	175	Ø 123	20	M20	37	232	235	35000
10182	10183	M20X200	57	200	Ø 123	20	M20	37	257	260	35000
10184	10185	M20X225	57	225	Ø 123	20	M20	37	282	285	35000
10186	10187	M20X250	57	250	Ø 123	20	M20	37	307	310	35000

• Materiale base: poliammide rinforzato con sfera di vetro. A richiesta disponibile con gomma antiscivolo NBR 70 shore (codice standard = senza gomma). Materiale stelo: acciaio inox AISI 304 (a richiesta AISI 316). Su richiesta l'elemento di livellamento viene fornito con dado in acciaio.

• I valori dei carichi sopra riportati sono calcolati in condizioni statiche alla metà della lunghezza dello stelo filettato. Qualora s'intendesse utilizzare i supporti in presenza di vibrazioni o carichi in movimento, tali valori dovranno essere adeguatamente ridotti. Per ulteriori chiarimenti consultare il nostro ufficio tecnico. Ogni nostra responsabilità decade in caso di manomissioni o modifiche dei componenti.

• Base in black polyamide material, reinforced by sphere glass. On request non-skid plate in NBR rubber 70 shore is available (Standard code = without rubber). Stainless steel screw in 1.4301 (1.4401 on specific request). The leveling mount could be supplied, on request, with steel nut.

• Load values above mentioned have to be considered referring to static conditions calculated at the half of the screw length. In conditions of vibrations or in presence of dynamic loads these values should be reduced. For further information consult our technical office. We cannot accept responsibility for mounts that have been tampered or modified.

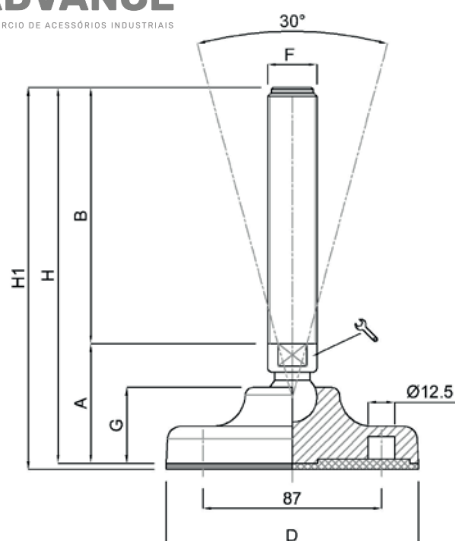

CODICE - CODE		descrizione description	DIMENSIONI PRINCIPALI - MAIN DIMENSIONS								CARICO STATICO STATIC LOAD NEWTON	
standard standard	antiscivolo antislip		A	B	D		F	G	H	H1		
10190	10191	M24X75	58	75	Ø 123	20	M24	37	133	136	35000	
10192	10193	M24X100	58	100	Ø 123	20	M24	37	158	161	35000	
10194	10195	M24X125	58	125	Ø 123	20	M24	37	183	186	35000	
*	10196	10197	M24X150	58	150	Ø 123	20	M24	37	208	211	35000
	10198	10199	M24X175	58	175	Ø 123	20	M24	37	233	236	35000
*	10200	10201	M24X200	58	200	Ø 123	20	M24	37	258	261	35000
	10202	10203	M24X225	58	225	Ø 123	20	M24	37	283	286	35000
	10204	10205	M24X250	58	250	Ø 123	20	M24	37	308	311	35000
	10206	10207	M30X100	59	100	Ø 123	26	M30	37	159	162	35000
	10208	10209	M30X125	59	125	Ø 123	26	M30	37	184	187	35000
*	10210	10211	M30X150	59	150	Ø 123	26	M30	37	209	212	35000
	10212	10213	M30X175	59	175	Ø 123	26	M30	37	234	237	35000
*	10214	10215	M30X200	59	200	Ø 123	26	M30	37	259	262	35000
	10216	10217	M30X225	59	225	Ø 123	26	M30	37	284	287	35000
	10218	10219	M30X250	59	250	Ø 123	26	M30	37	309	312	35000

* Disponibile con Filettatura a passo fine. Aggiungere "/P2" al codice
Available with Thin pitch thread. Please, add "/P2" to the code

- Materiale base: poliammide rinforzato con sfera di vetro. A richiesta disponibile con gomma antiscivolo NBR 70 shore (codice standard = senza gomma). Materiale stelo: acciaio inox AISI 304 (a richiesta AISI 316). Su richiesta l'elemento di livellamento viene fornito con dado in acciaio.
- I valori dei carichi sopra riportati sono calcolati in condizioni statiche alla metà della lunghezza dello stelo filettato. Qualora s'intendesse utilizzare i supporti in presenza di vibrazioni o carichi in movimento, tali valori dovranno essere adeguatamente ridotti. Per ulteriori chiarimenti consultare il nostro ufficio tecnico. Ogni nostra responsabilità decade in caso di manomissioni o modifiche dei componenti.
- Base in black polyamide material, reinforced by sphere glass. On request non-skid plate in NBR rubber 70 shore is available (Standard code = without rubber). Stainless steel screw in 1.4301 (1.4401 on specific request). The leveling mount could be supplied, on request, with steel nut.
- Load values above mentioned have to be considered referring to static conditions calculated at the half of the screw length. In conditions of vibrations or in presence of dynamic loads these values should be reduced. For further information consult our technical office. We cannot accept responsibility for mounts that have been tampered or modified.

Caratteristiche: BASE Ø 123, STELO SNODATO 30°

Features: BASE Ø 123, 30° ARTICULATED STEM

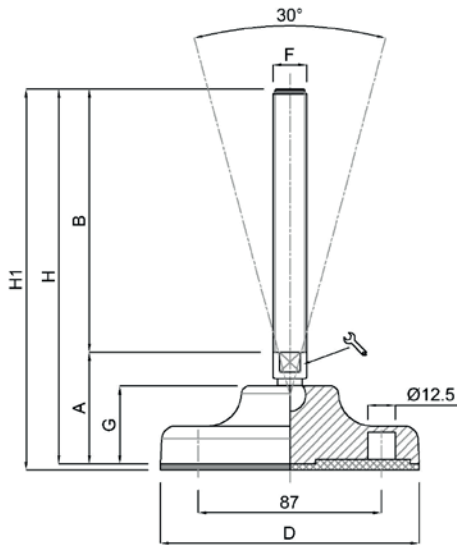

CODICE - CODE		descrizione description	DIMENSIONI PRINCIPALI - MAIN DIMENSIONS								CARICO STATICO STATIC LOAD NEWTON
standard standard	antiscivolo antislip		A	B	D		F	G	H	H1	
10154/15	10155/15	M16X50	53	50	Ø 123	13	M16	37	103	106	25000
10158/15	10159/15	M16X100	53	100	Ø 123	13	M16	37	153	156	25000
10162/15	10163/15	M16X150	53	150	Ø 123	13	M16	37	203	206	25000
10166/15	10167/15	M16X200	53	200	Ø 123	13	M16	37	253	256	25000
10174/20	10175/20	M20X100	55	100	Ø 123	17	M20	37	155	158	25000
10178/20	10179/20	M20X150	55	150	Ø 123	17	M20	37	205	208	25000
10182/20	10183/20	M20X200	55	200	Ø 123	17	M20	37	255	258	25000

- Materiale base: poliammide rinforzato con sfera di vetro. A richiesta disponibile con gomma antiscivolo NBR 70 shore (codice standard = senza gomma). Materiale stelo: acciaio inox AISI 304 (a richiesta AISI 316). Su richiesta l'elemento di livellamento viene fornito con dado in acciaio.
- I valori dei carichi sopra riportati sono calcolati in condizioni statiche alla metà della lunghezza dello stelo filettato. Qualora s'intendesse utilizzare i supporti in presenza di vibrazioni o carichi in movimento, tali valori dovranno essere adeguatamente ridotti. Per ulteriori chiarimenti consultare il nostro ufficio tecnico. Ogni nostra responsabilità decade in caso di manomissioni o modifiche dei componenti.
- Base in black polyamide material, reinforced by sphere glass. On request non-skid plate in NBR rubber 70 shore is available (Standard code = without rubber). Stainless steel screw in 1.4301 (1.4401 on specific request). The leveling mount could be supplied, on request, with steel nut.
- Load values above mentioned have to be considered referring to static conditions calculated at the half of the screw length. In conditions of vibrations or in presence of dynamic loads these values should be reduced. For further information consult our technical office. We cannot accept responsibility for mounts that have been tampered or modified.

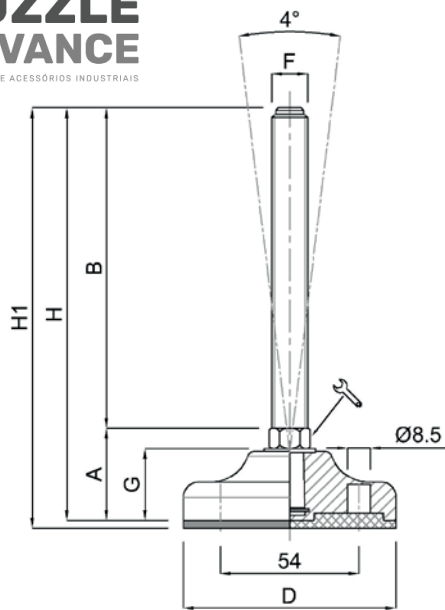

CODICE - CODE		descrizione <i>description</i>	DIMENSIONI PRINCIPALI - MAIN DIMENSIONS								CARICO STATICO STATIC LOAD NEWTON
standard <i>standard</i>	antiscivolo <i>antislip</i>		A	B	D		F	G	H	H1	
12630/10	12631/10	M10X50	36	50	Ø 83	14	M10	28	86	89	15000
12632/10	12633/10	M10X75	36	75	Ø 83	14	M10	28	111	114	15000
12634/10	12635/10	M10X100	36	100	Ø 83	14	M10	28	136	139	15000
12636/10	12637/10	M10X125	36	125	Ø 83	14	M10	28	161	164	15000
12630/12	12631/12	M12X50	36	50	Ø 83	14	M12	28	86	89	15000
12632/12	12633/12	M12X75	36	75	Ø 83	14	M12	28	111	114	15000
12634/12	12635/12	M12X100	36	100	Ø 83	14	M12	28	136	139	15000
12636/12	12637/12	M12X125	36	125	Ø 83	14	M12	28	161	164	15000
12630	12631	M14X50	36	50	Ø 83	14	M14	28	86	89	20000
12632	12633	M14X75	36	75	Ø 83	14	M14	28	111	114	20000
12634	12635	M14X100	36	100	Ø 83	14	M14	28	136	139	20000
12636	12637	M14X125	36	125	Ø 83	14	M14	28	161	164	20000
12638	12639	M14X150	36	150	Ø 83	14	M14	28	186	189	20000
12640	12641	M14X175	36	175	Ø 83	14	M14	28	212	215	20000

• Materiale base: poliammide rinforzato con sfera di vetro. A richiesta disponibile con gomma antiscivolo NBR 70 shore (codice standard = senza gomma). Materiale stelo: acciaio inox AISI 304 (a richiesta AISI 316). Su richiesta l'elemento di livellamento viene fornito con dado in acciaio.

• I valori dei carichi sopra riportati sono calcolati in condizioni statiche alla metà della lunghezza dello stelo filettato. Qualora s'intendesse utilizzare i supporti in presenza di vibrazioni o carichi in movimento, tali valori dovranno essere adeguatamente ridotti. Per ulteriori chiarimenti consultare il nostro ufficio tecnico. Ogni nostra responsabilità decade in caso di manomissioni o modifiche dei componenti.

• Base in black polyamide material, reinforced by sphere glass. On request non-skid plate in NBR rubber 70 shore is available (Standard code = without rubber). Stainless steel screw in 1.4301 (1.4401 on specific request). The leveling mount could be supplied, on request, with steel nut.

• Load values above mentioned have to be considered referring to static conditions calculated at the half of the screw length. In conditions of vibrations or in presence of dynamic loads these values should be reduced. For further information consult our technical office. We cannot accept responsibility for mounts that have been tampered or modified.

Caratteristiche: BASE Ø 83, STELO FISSO

Features: BASE Ø 83, FIX STEM

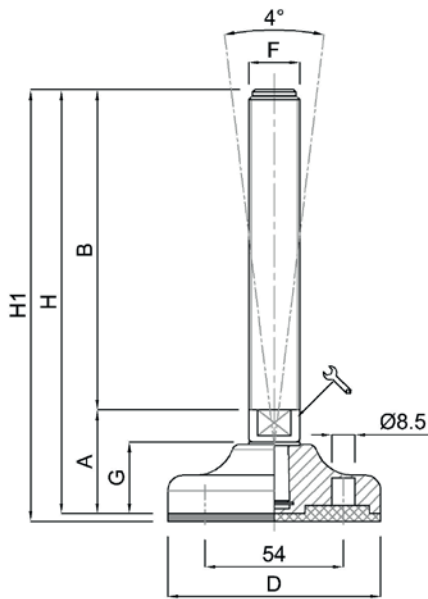

CODICE - CODE		descrizione <i>description</i>	DIMENSIONI PRINCIPALI - MAIN DIMENSIONS								CARICO STATICO STATIC LOAD NEWTON
standard <i>standard</i>	antiscivolo <i>antislip</i>		A	B	D		F	G	H	H1	
12658	12659	M16X50	40	50	Ø 83	13	M16	28	90	93	20000
12660	12661	M16X75	40	75	Ø 83	13	M16	28	115	118	20000
12662	12663	M16X100	40	100	Ø 83	13	M16	28	140	143	20000
12664	12665	M16X125	40	125	Ø 83	13	M16	28	165	168	20000
12666	12667	M16X150	40	150	Ø 83	13	M16	28	190	193	20000
12668	12669	M16X175	40	175	Ø 83	13	M16	28	215	218	20000
12670	12671	M16X200	40	200	Ø 83	13	M16	28	240	243	20000
12688	12689	M20X75	40	75	Ø 83	17	M20	28	115	118	20000
12690	12691	M20X100	40	100	Ø 83	17	M20	28	140	143	20000
12692	12693	M20X125	40	125	Ø 83	17	M20	28	165	168	20000
12694	12695	M20X150	40	150	Ø 83	17	M20	28	190	193	20000
12696	12697	M20X175	40	175	Ø 83	17	M20	28	215	218	20000
12698	12699	M20X200	40	200	Ø 83	17	M20	28	240	243	20000
12700	12701	M20X225	40	225	Ø 83	17	M20	28	265	268	20000

- Materiale base: poliammide rinforzato con sfera di vetro. A richiesta disponibile con gomma antiscivolo NBR 70 shore (codice standard = senza gomma). Materiale stelo: acciaio inox AISI 304 (a richiesta AISI 316). Su richiesta l'elemento di livellamento viene fornito con dado in acciaio.
- I valori dei carichi sopra riportati sono calcolati in condizioni statiche alla metà della lunghezza dello stelo filettato. Qualora s'intendesse utilizzare i supporti in presenza di vibrazioni o carichi in movimento, tali valori dovranno essere adeguatamente ridotti. Per ulteriori chiarimenti consultare il nostro ufficio tecnico. Ogni nostra responsabilità decade in caso di manomissioni o modifiche dei componenti.
- Base in black polyamide material, reinforced by sphere glass. On request non-skid plate in NBR rubber 70 shore is available (Standard code = without rubber). Stainless steel screw in 1.4301 (1.4401 on specific request). The leveling mount could be supplied, on request, with steel nut.
- Load values above mentioned have to be considered referring to static conditions calculated at the half of the screw length. In conditions of vibrations or in presence of dynamic loads these values should be reduced. For further information consult our technical office. We cannot accept responsibility for mounts that have been tampered or modified.

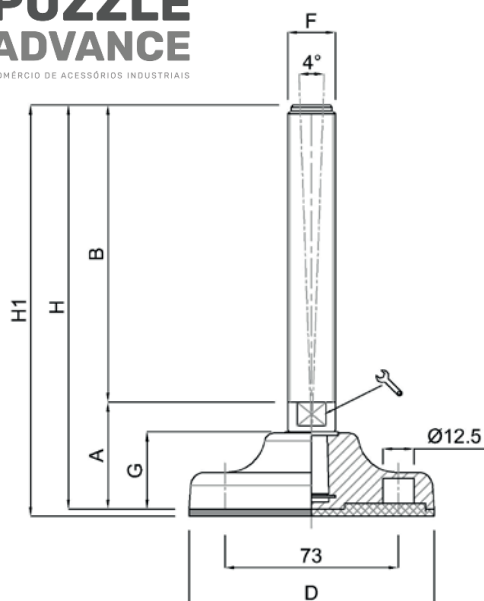

CODICE - CODE		descrizione description	DIMENSIONI PRINCIPALI - MAIN DIMENSIONS								CARICO STATICO STATIC LOAD NEWTON
standard standard	antiscivolo antislip		A	B	D		F	G	H	H1	
12718	12719	M16X50	45	50	Ø 103	17	M16	33	95	98	35000
12720	12721	M16X75	45	75	Ø 103	17	M16	33	120	123	35000
12722	12723	M16X100	45	100	Ø 103	17	M16	33	145	148	35000
12724	12725	M16X125	45	125	Ø 103	17	M16	33	170	173	35000
12726	12727	M16X150	45	150	Ø 103	17	M16	33	195	198	35000
12728	12729	M16X175	45	175	Ø 103	17	M16	33	220	223	35000
12730	12731	M16X200	45	200	Ø 103	17	M16	33	245	248	35000
12732	12733	M16X225	45	225	Ø 103	17	M16	33	270	273	35000
12752	12753	M20X75	45	75	Ø 103	17	M20	33	120	123	35000
12754	12755	M20X100	45	100	Ø 103	17	M20	33	145	148	35000
12756	12757	M20X125	45	125	Ø 103	17	M20	33	170	173	35000
12758	12759	M20X150	45	150	Ø 103	17	M20	33	195	198	35000
12760	12761	M20X175	45	175	Ø 103	17	M20	33	220	223	35000
12762	12763	M20X200	45	200	Ø 103	17	M20	33	245	248	35000
12764	12765	M20X225	45	225	Ø 103	17	M20	33	270	273	35000
12784	12785	M24X75	47	75	Ø 103	20	M24	33	122	125	35000
12786	12787	M24X100	47	100	Ø 103	20	M24	33	147	150	35000
12788	12789	M24X125	47	125	Ø 103	20	M24	33	172	175	35000
* 12790	12791	M24X150	47	150	Ø 103	20	M24	33	197	200	35000
* 12792	12793	M24X175	47	175	Ø 103	20	M24	33	222	225	35000
* 12794	12795	M24X200	47	200	Ø 103	20	M24	33	247	250	35000
12796	12797	M24X225	47	225	Ø 103	20	M24	33	272	275	35000

* Disponibile con Filettatura a passo fine. Aggiungere "/IP2" al codice
Available with Thin pitch thread. Please, add "/IP2" to the code

- Materiale base: poliammide rinforzato con sfera di vetro. A richiesta disponibile con gomma antiscivolo NBR 70 shore (codice standard = senza gomma). Materiale stelo: acciaio inox AISI 304 (a richiesta AISI 316). Su richiesta l'elemento di livellamento viene fornito con dado in acciaio.
- I valori dei carichi sopra riportati sono calcolati in condizioni statiche alla metà della lunghezza dello stelo filettato. Qualora s'intendesse utilizzare i supporti in presenza di vibrazioni o carichi in movimento, tali valori dovranno essere adeguatamente ridotti. Per ulteriori chiarimenti consultare il nostro ufficio tecnico. Ogni nostra responsabilità decade in caso di manomissioni o modifiche dei componenti.
- Base in black polyamide material, reinforced by sphere glass. On request non-skid plate in NBR rubber 70 shore is available (Standard code = without rubber). Stainless steel screw in 1.4301 (1.4401 on specific request). The leveling mount could be supplied, on request, with steel nut.
- Load values above mentioned have to be considered referring to static conditions calculated at the half of the screw length. In conditions of vibrations or in presence of dynamic loads these values should be reduced. For further information consult our technical office. We cannot accept responsibility for mounts that have been tampered or modified.

Piede in Polyamide & Inox

PLASTICA

Martin
Levelling Components

PLASTICA

Caratteristiche: BASE Ø 123, STELO FISSO

Features: BASE Ø 123, FIX STEM

**PUZZLE
ADVANCE**
COMÉRCIO DE ACESSÓRIOS INDUSTRIAIS

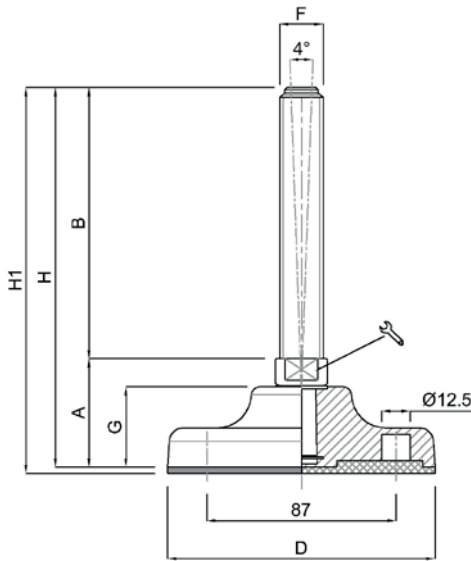

CODICE - CODE		descrizione description	DIMENSIONI PRINCIPALI - MAIN DIMENSIONS								CARICO STATICO STATIC LOAD NEWTON
standard standard	antiscivolo antislip		A	B	D		F	G	H	H1	
12814	12815	M16X50	50	50	Ø 123	20	M16	37	100	103	45000
12816	12817	M16X75	50	75	Ø 123	20	M16	37	125	128	45000
12818	12819	M16X100	50	100	Ø 123	20	M16	37	150	153	45000
12820	12821	M16X125	50	125	Ø 123	20	M16	37	175	178	45000
12822	12823	M16X150	50	150	Ø 123	20	M16	37	200	203	45000
12824	12825	M16X175	50	175	Ø 123	20	M16	37	225	228	45000
12826	12827	M16X200	50	200	Ø 123	20	M16	37	250	253	45000
12828	12829	M16X225	50	225	Ø 123	20	M16	37	275	278	45000
12848	12849	M20X75	50	75	Ø 123	20	M20	37	125	128	45000
12850	12851	M20X100	50	100	Ø 123	20	M20	37	150	153	45000
12852	12853	M20X125	50	125	Ø 123	20	M20	37	175	178	45000
12854	12855	M20X150	50	150	Ø 123	20	M20	37	200	203	45000
12856	12857	M20X175	50	175	Ø 123	20	M20	37	225	228	45000
12858	12859	M20X200	50	200	Ø 123	20	M20	37	250	253	45000
12860	12861	M20X225	50	225	Ø 123	20	M20	37	275	278	45000
12818/20	12819/20	M16X100	50	100	Ø 123	17	M16	37	150	153	40000
12822/20	12823/20	M16X150	50	150	Ø 123	17	M16	37	200	203	40000
12826/20	12827/20	M16X200	50	200	Ø 123	17	M16	37	250	253	40000
12850/20	12851/20	M20X100	50	100	Ø 123	17	M20	37	150	153	40000
12854/20	12855/20	M20X150	50	150	Ø 123	17	M20	37	200	203	40000
12858/20	12859/20	M20X200	50	200	Ø 123	17	M20	37	250	253	40000

- Materiale base: poliammide rinforzato con sfera di vetro. A richiesta disponibile con gomma antiscivolo NBR 70 shore (codice standard = senza gomma). Materiale stelo: acciaio inox AISI 304 (a richiesta AISI 316). Su richiesta l'elemento di livellamento viene fornito con dado in acciaio.
- I valori dei carichi sopra riportati sono calcolati in condizioni statiche alla metà della lunghezza dello stelo filettato. Qualora s'intendesse utilizzare i supporti in presenza di vibrazioni o carichi in movimento, tali valori dovranno essere adeguatamente ridotti. Per ulteriori chiarimenti consultare il nostro ufficio tecnico. Ogni nostra responsabilità decade in caso di manomissioni o modifiche dei componenti.
- Base in black polyamide material, reinforced by sphere glass. On request non-skid plate in NBR rubber 70 shore is available (Standard code = without rubber). Stainless steel screw in 1.4301 (1.4401 on specific request). The leveling mount could be supplied, on request, with steel nut.
- Load values above mentioned have to be considered referring to static conditions calculated at the half of the screw length. In conditions of vibrations or in presence of dynamic loads these values should be reduced. For further information consult our technical office. We cannot accept responsibility for mounts that have been tampered or modified.

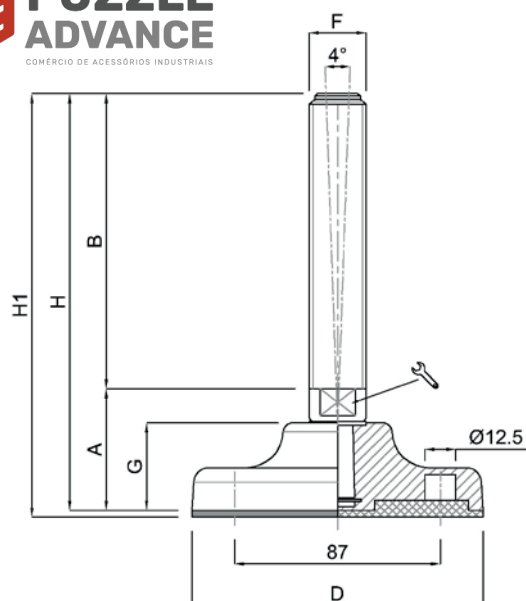

CODICE - CODE		descrizione description	DIMENSIONI PRINCIPALI - MAIN DIMENSIONS								CARICO STATICO STATIC LOAD NEWTON
standard standard	antiscivolo antislip		A	B	D		F	G	H	H1	
12878	12879	M24X75	50	75	Ø 123	20	M24	37	125	128	45000
12880	12881	M24X100	50	100	Ø 123	20	M24	37	150	153	45000
12882	12883	M24X125	50	125	Ø 123	20	M24	37	175	178	45000
* 12884	12885	M24X150	50	150	Ø 123	20	M24	37	200	203	45000
12886	12887	M24X175	50	175	Ø 123	20	M24	37	225	228	45000
* 12888	12889	M24X200	50	200	Ø 123	20	M24	37	250	253	45000
12890	12891	M24X225	50	225	Ø 123	20	M24	37	275	278	45000
12892	12893	M24X250	50	250	Ø 123	20	M24	37	300	303	45000
12910	12911	M30X100	50	100	Ø 123	26	M30	37	150	153	45000
12912	12913	M30X125	50	125	Ø 123	26	M30	37	175	178	45000
* 12914	12915	M30X150	50	150	Ø 123	26	M30	37	200	203	45000
12916	12917	M30X175	50	175	Ø 123	26	M30	37	225	228	45000
* 12918	12919	M30X200	50	200	Ø 123	26	M30	37	250	253	45000
12920	12921	M30X225	50	225	Ø 123	26	M30	37	275	278	45000
12922	12923	M30X250	50	250	Ø 123	26	M30	37	300	303	45000

* Disponibile con Filettatura a passo fine. Aggiungere "/P2" al codice
Available with Thin pitch thread. Please, add "/P2" to the code

- Materiale base: poliammide rinforzato con sfera di vetro. A richiesta disponibile con gomma antiscivolo NBR 70 shore (codice standard = senza gomma). Materiale stelo: acciaio inox AISI 304 (a richiesta AISI 316). Su richiesta l'elemento di livellamento viene fornito con dado in acciaio.
- I valori dei carichi sopra riportati sono calcolati in condizioni statiche alla metà della lunghezza dello stelo filettato. Qualora s'intendesse utilizzare i supporti in presenza di vibrazioni o carichi in movimento, tali valori dovranno essere adeguatamente ridotti. Per ulteriori chiarimenti consultare il nostro ufficio tecnico. Ogni nostra responsabilità decade in caso di manomissioni o modifiche dei componenti.
- Base in black polyamide material, reinforced by sphere glass. On request non-skid plate in NBR rubber 70 shore is available (Standard code = without rubber). Stainless steel screw in 1.4301 (1.4401 on specific request). The leveling mount could be supplied, on request, with steel nut.
- Load values above mentioned have to be considered referring to static conditions calculated at the half of the screw length. In conditions of vibrations or in presence of dynamic loads these values should be reduced. For further information consult our technical office. We cannot accept responsibility for mounts that have been tampered or modified.