

## LINEA TEKNO-FIX TEKNO-FIX LINE

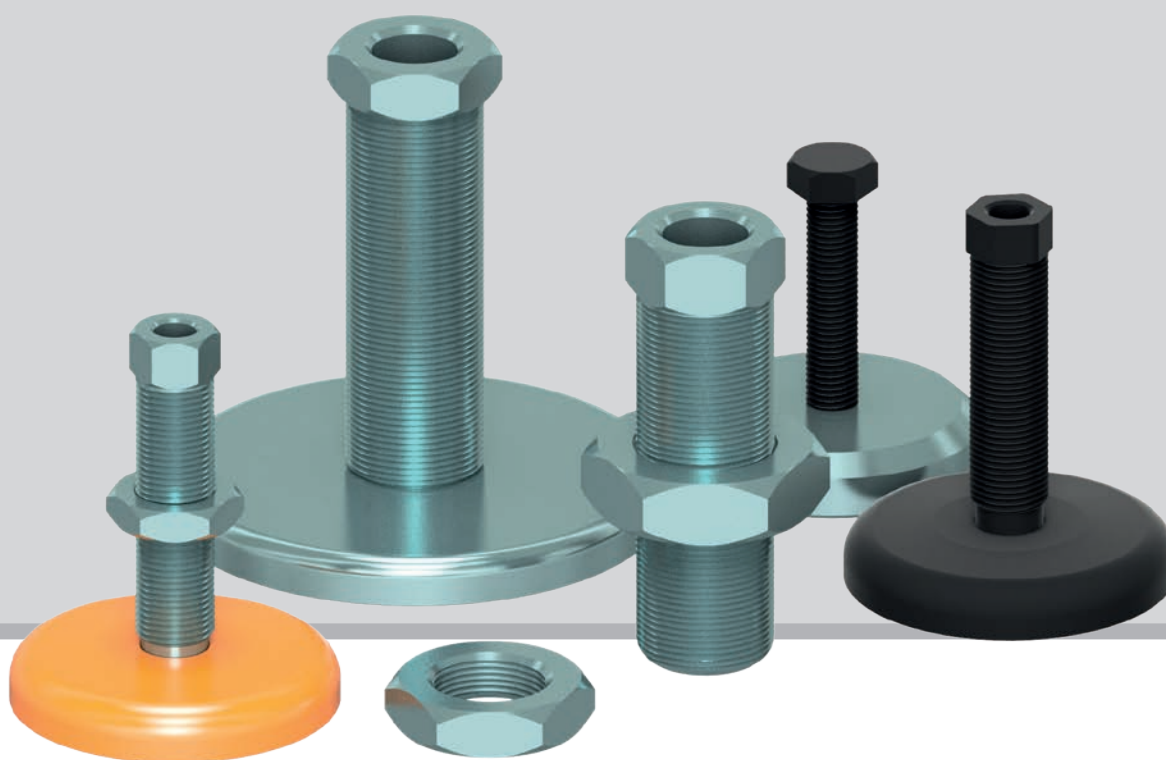

TEKNO-FIX

**PAG. 266**      TEKNO-FIX INOX

**PAG. 267**      TEKNO-FIX

**PAG. 269**      VITI A REGISTRO  
*ADJUSTING SCREWS*

**PAG. 272**      PIEDE RETTANGOLARE  
*RECTANGULAR FOOT*

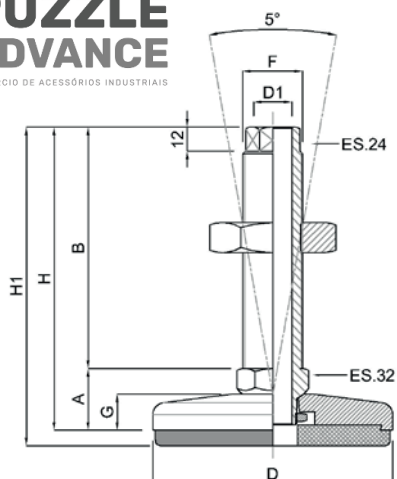

CODICE CODE	DIMENSIONI PRINCIPALI - MAIN DIMENSIONS								CARICO STATICO STATIC LOAD NEWTON
	STANDARD	A	B	D	F	G	D1	H	
126011	31	121	ø 120	M30x1.5	18	19	152	160	45000

Materiale:

- . Base acciaio inox AISI304
- . Stelo acciaio inox AISI303
- . Gomma per Base antiscivolo FDA NBR nero 90Shore
- . Dado per attacco acciaio inox AISI304

MaterialS

- . Stainless Steel AISI304 Base
- . Stainless Steel AISI303 stem
- . Anti-slip pad black FDA NBR rubber 90Shore
- . Stainless Steel AISI304 nut

**COME USARE TEKNO-FIX**  
**HOW TO USE TEKNO-FIX**

1.



Posizionare il Piede di livellamento TeknoFix nel luogo prestabilito per l'utilizzo del proprio macchinario.

*Place the TeknoFix Levelling Foot in the designated location for the use of your machine.*

2.



Quando il piede di livellamento e il macchinario sono nella posizione corretta eseguire la foratura nel pavimento tramite il foro passante tra stelo e base.

*When the levelling foot and the machine are in the correct position it is possible to fix the foot using a Fischer so you have to pierce the pavement.*

3.



Successivamente è opportuno inserire un perno filettato da fissare con resina o fischer.

*Then it is advisable to insert a threaded pin to completely fix the leveling foot with glue.*

4.



Infine si ottiene un piede di livellamento completamente fisso al suolo privo di fori a vista con la possibilità di regolarlo in altezza.

*Finally, the levelling foot is completely fixed to the ground without visible holes and can be adjusted in height.*

# Piede in Acciaio Verniciato, Zincato e Fosfatato

## TEKNO-FIX

Martin  
Levelling Components

**Caratteristiche: BASE E VITE CON FORO PASSANTE, PASSO FINE**

**Features: BASE AND SCREW WITH THROUGH HOLE, THIN PITCH**

**PUZZLE  
ADVANCE**  
COMERCIO DE ACESSÓRIOS INDUSTRIAIS

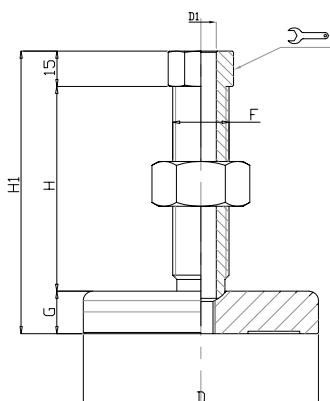

CODICE - CODE standard - standard	DIMENSIONI PRINCIPALI - MAIN DIMENSIONS							CARICO STATICO STATIC LOAD NEWTON
	D	D1		F	G	H	H1	
12620V	Ø 100	Ø 13	24	M24X2	18	141	174	60000
12620F	Ø 100	Ø 13	24	M24X2	18	141	174	60000
12621V	Ø 100	Ø 13	24	M24X2	18	87	120	60000
12621F	Ø 100	Ø 13	24	M24X2	18	87	120	60000
12617V	Ø 120	Ø 22	41	M35X2	25	100	140	90000
12617F	Ø 120	Ø 22	41	M35X2	25	100	140	90000
12618V	Ø 120	Ø 22	41	M36X2	25	100	140	90000
12618F	Ø 120	Ø 22	41	M36X2	25	100	140	90000
12619V	Ø 120	Ø 22	41	M35X2	25	177	217	90000
12619F	Ø 120	Ø 22	41	M35X2	25	177	217	90000
12623V	Ø 150	Ø 22	41	M35X2	25	100	140	90000
12623F	Ø 150	Ø 22	41	M35X2	25	100	140	90000
12624V	Ø 150	Ø 22	41	M36X2	25	100	140	90000
12624F	Ø 150	Ø 22	41	M36X2	25	100	140	90000
12625V	Ø 150	Ø 22	41	M35X2	25	177	217	90000
12625F	Ø 150	Ø 22	41	M35X2	25	177	217	90000
12626V	Ø 150	Ø 22	41	M36X2	25	177	217	90000
12626F	Ø 150	Ø 22	41	M36X2	25	177	217	90000

Codice + V = finitura verniciata  
Codice + F = finitura fosfatata

"V" CODE = surface finishing: yellow painted  
"F" CODE = surface finishing: phosphated

## TEKNO-FIX CNC

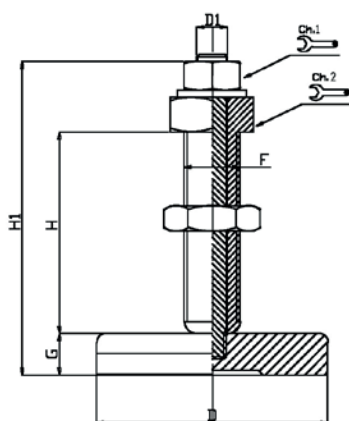

CODICE - CODE STANDARD - standard	DIMENSIONI PRINCIPALI - MAIN DIMENSIONS							CARICO SCARICO STARTING LOAD NEWTON
	D	D1	CH1/CH2	F	G	H	H1	
12622	Ø 80	Ø 16	24 36	M30x2	20	75	126	70000
12627	Ø 68	Ø 12	19 27	M27x2	25	78	134	65000
12627/60	Ø 68	Ø 12	19 27	M27x2	25	63	113	65000
12627/90	Ø 68	Ø 12	19 27	M27x2	25	93	143	65000
12627/110	Ø 68	Ø 12	19 27	M27x2	25	108	163	65000
12627/130	Ø 68	Ø 12	19 27	M27x2	25	128	183	65000

TEKNO-FIX

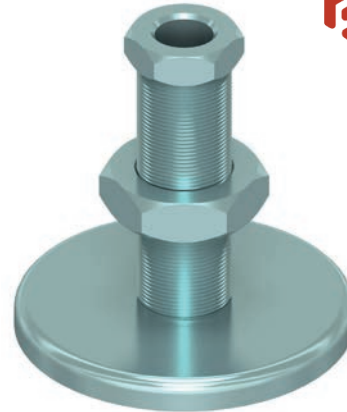
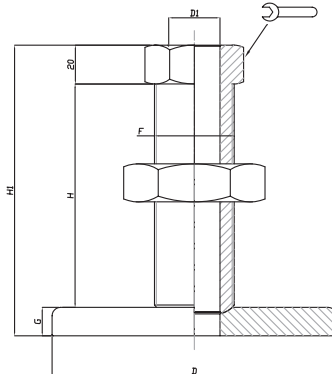
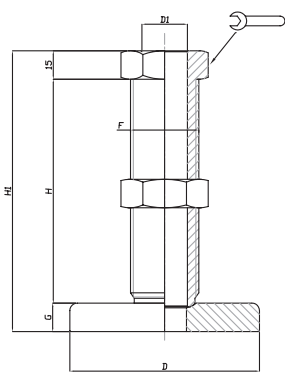

CODICE - CODE	D	D1		F	G	H	H1	CARICO STATICO STATIC LOAD NEWTON
12628	Ø 150	26	46	M42x2	15	119	154	100000
12629	Ø 100	22	41	M36x3	15	118	148	90000

**Caratteristiche: BASE CON NICCHIA, VITE ESAGONALE**

**Features: BASE WITH NICHE, HEXAGONAL SCREW**

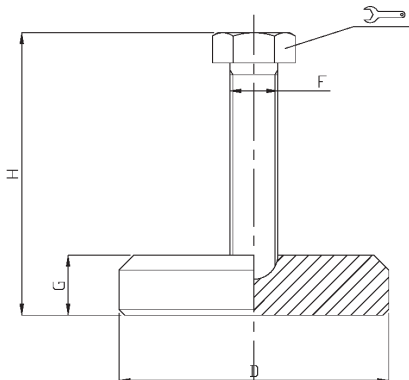

CODICE - CODE	D		F	G	H	CARICO STATICO STATIC LOAD NEWTON
12345	Ø 90	24	16	20	60	35000
12347	Ø 90	24	16	20	80	35000

• Materiale base: acciaio zincato C40.  
Materiale stelo: acciaio brunito.

• Galvanized steel base (C40).  
Burnished screw.

## Viti a Registro Zincate e Fosfatate

TEKNO-FIX

Martin  
Levelling Components

Caratteristiche: VITE CON FORO PASSANTE, PASSO FINE

Features: SCREW WITH THROUGH HOLE, THIN PITCH

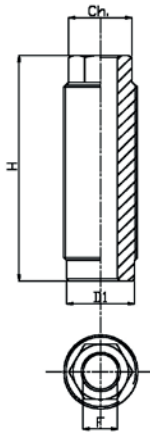

**PUZZLE ADVANCE**  
COMÉRCIO DE ACESSÓRIOS INDUSTRIAIS



CODICE - CODE	DIMENSIONE BASE BASE DIMENSION	H		D1	F	CARICO STATICO STATIC LOAD NEWTON
19100Z/1.5	M30X1.5	110	24	27	17	70000
19100F/1.5	M30X1.5	110	24	27	17	70000
19100Z	M30X2	110	24	27	17	70000
19100F	M30X2	110	24	27	17	70000
19101Z	M36X2	110	27	33	17	90000
19101F	M36X2	110	27	33	17	90000
19101Z/F21	M36X2	110	27	33	21	90000
19101F/F21	M36X2	110	27	33	21	90000

Codice + Z = finitura zincata

Codice + F = finitura fosfatata

- Materiale: acciaio zincato FE. Applicazioni: macchine utensili, basamenti macchina
- Material: galvanized steel. Application: machine tools, machine beds a.s.o.

""Z" CODE = surface finishing: zinc

""F" CODE = surface finishing: phosphated

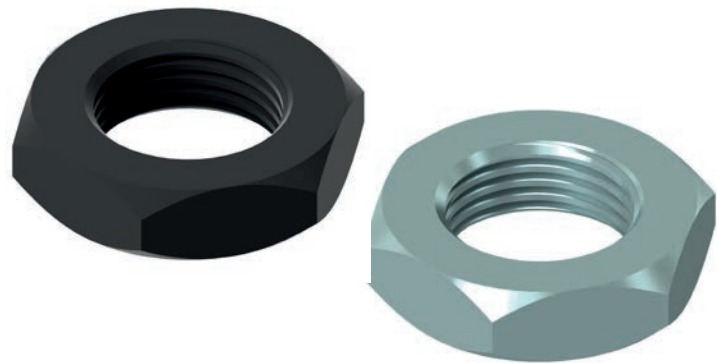
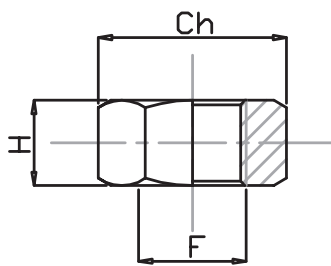



CODICE - CODE		F	CH	H
ZINCATA	FOSFATATA			
DD24X2Z	DD24X2F	M24x2	36	18
DD27X2Z	DD27X2F	M27x2	41	12
DD30X2Z	DD30X2F	M30x2	36	11
DD35X2Z	DD35X2F	M35x2	55	15
DD36X2Z	DD36X2F	M36x2	55	15
DD36X3Z	DD36X3F	M36x3	55	15
DD42X2Z	DD42X2F	M42x2	65	20

- Materiale: acciaio zincato FE. Applicazioni: macchine utensili, basamenti macchina

- Material: galvanized steel. Application: machine tools, machine beds a.s.o.

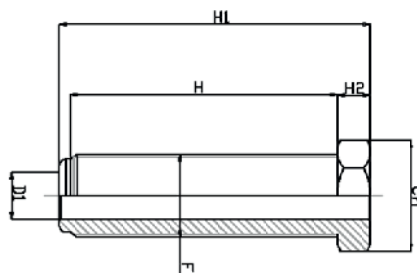
TEKNO-FIX



CODICE - CODE		DESCRIZIONE DESCRIPTION	H1	H2	H		D1	F	CARICO STATICO STATIC LOAD NEWTON
ZINCATA	FOSFATATA								
19110Z	19110F	VITE M36x3	135	15	116	41	22	36x3	90000

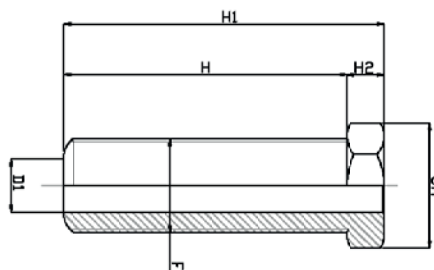

CODICE - CODE		DESCRIZIONE DESCRIPTION	H1	H2	H		D1	F	CARICO STATICO STATIC LOAD NEWTON
ZINCATA	FOSFATATA								
19111Z	19111F	VITE M42x2	140	20	120	46	26	42x2	100000

# Viti a Registro Zincate e Fosfatate

TEKNO-FIX

Caratteristiche: VITE CON FORO PASSANTE, PASSO FINE

Features: SCREW WITH THROUGH HOLE, THIN PITCH

Martin  
Levelling Components

**PUZZLE  
ADVANCE**  
COMÉRCIO DE ACESSÓRIOS INDUSTRIAIS

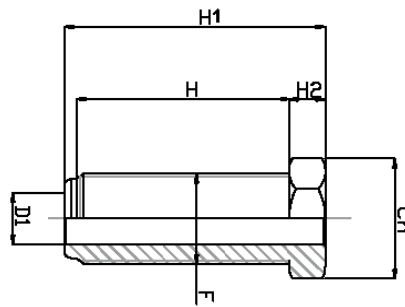

CODICE - CODE		DESCRIZIONE DESCRIPTION	H1	H2	H		D1	F	CARICO STATICO STATIC LOAD NEWTON
ZINCATA	FOSFATATA								
19112Z	19112F	VITE M30x2	87	12	70	36	17	30x2	70000

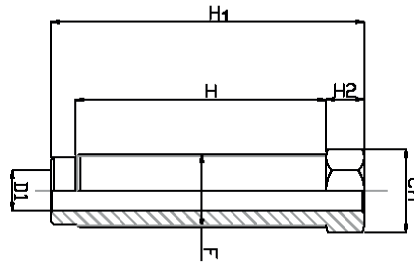

CODICE - CODE		DESCRIZIONE DESCRIPTION	H1	H2	H		D1	F	CARICO STATICO STATIC LOAD NEWTON
ZINCATA	FOSFATATA								
19106z	19106F	VITE M27X2	90	12	70	27	15	27x2	65000
19107Z	19107F	VITE M27X2	110	12	91	27	15	27x2	65000
19108Z	19108F	VITE M27X2	125	12	106	27	15	27x2	65000
19109Z	19109F	VITE M27X2	145	12	126	27	15	27x2	65000

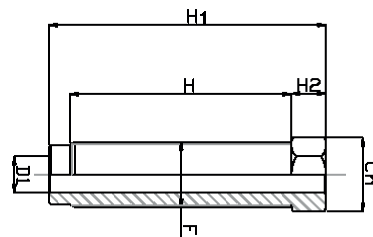

CODICE - CODE		"DESCRIZIONE DESCRIPTION"	H1	H2	H	CH	D1	F	CARICO STATICO STATIC LOAD NEWTON
ZINCATA	FOSFATATA								
19080Z/E27	19080F/E27	M24x3	105	15	85	27	13	M24x3	60000
19090Z/E27	19090F/E27	M24x3	160	15	136	27	13	M24x3	60000
19080Z	19080F	M24x3	105	15	85	24	13	M24x3	60000
19080Z/1.5	19080F/1.5	M24x1.5	105	15	85	24	13	M24x1.5	50000
19090Z	19090F	M24x3	160	15	136	24	13	M24x3	60000
19090Z/SF	19090F/SF	M24x2	160	15	136	24	-	M24x2	60000
19102Z	19102F	M35x2	120	15	95	41	22	M35x2	90000
19103Z	19103F	M35x2	195	15	170	41	22	M35x2	90000
19104Z	19104F	M36x2	120	15	95	41	22	M36x2	90000
19105Z	19105F	M36x2	195	15	170	41	22	M36x2	90000

TEKNO-FIX

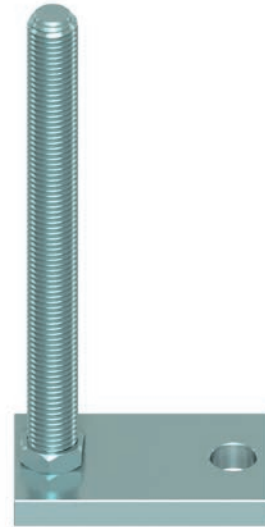
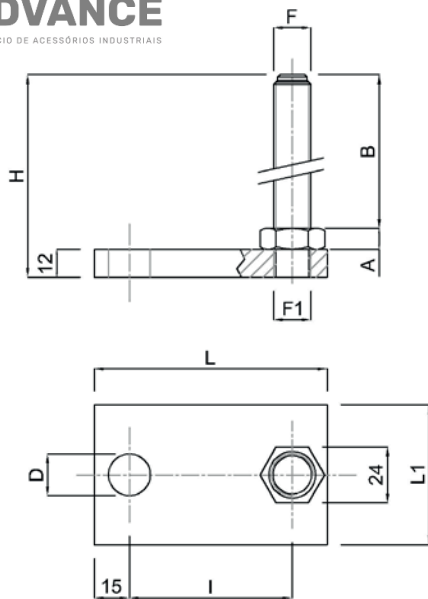

CODICE CODE	DIMENSIONE BASE BASE SIZE				DIMENSIONE STELO STEM SIZE			F1	H	CARICO STATICO STATIC LOAD NEWTON
	L	L1	I	D	A	B	F			
19000	100	60	70	ø 18	9	150	M16	M16	171	30000
19001	110	80	80	ø 18	9	200	M20	M20	221	40000
19002	200	80	160	ø 18	10	200	M24	M20	222	45000

- Materiale base: acciaio zincato C40. Materiale stelo: acciaio zincato FE. Su richiesta l'elemento di livellamento viene fornito con dado in acciaio
- I valori dei carichi sopra riportati sono calcolati in condizioni statiche alla metà della lunghezza dello stelo filettato. Qualora s'intendesse utilizzare i supporti in presenza di vibrazioni o carichi in movimento, tali valori dovranno essere adeguatamente ridotti. Per ulteriori chiarimenti consultare il nostro ufficio tecnico. Ogni nostra responsabilità decade in caso di manomissioni o modifiche dei componenti.
- *Galvanized steel base (C40). Fixed galvanized steel screw. The leveling element could be supplied, on request, with steel nut.*
- *Load values above mentioned have to be considered referring to static conditions calculated at the half of the screw length. In conditions of vibrations or in presence of dynamic loads these values should be reduced. For further information consult our technical office. We cannot accept responsibility for mounts that have been tampered or modified*