

LINEAR ROLLER SYSTEM

with ML rail and RL, RLS sliders

The ML Series Linear Roller System consists of a C shaped steel rail with internal concave raceways where robust ball bearing rollers travel. The high precision rollers are lubricated for life and protected with 2Z seals. Sliders are available with three or five rollers including eccentrics to adjust the slider's preload. Both ends of the sliders are equipped with polyamide wipers to remove debris from the raceway and grease impregnated felt wipers to lubricate the raceways for long life with minimal maintenance.

Sliders include a mix of concentric and eccentric rollers. The eccentric rollers are used to preload the system and eliminate any play. The preload can be adjusted to suit the particular application. Sliders are able to carry load and moment loads in all direction. Because one of the rail raceways contacts more rollers than the other, this direction is the preferred direction of radial loading. Two small circular marks indicate the direction of preferred slider loading.

The ML Systems's C shaped steel rail has internal raceways that are protected from accidental damage. Similarly, the rollers are protected inside the rail and under the slider body.

Overall, the ML Series Linear Rail Systems is easy to assembly and extremely compact.

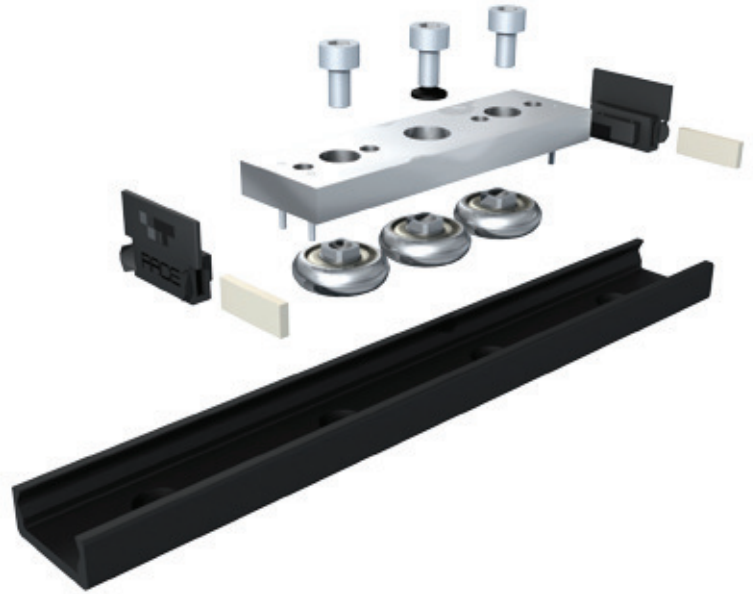

RL Series Sliders

are made of strong zinc plated steel body, with mounting holes parallel to the roller axis and perpendicular to the direction of preferred loading. The sliders have wipers which incorporate preoiled felt for lubrication of raceways.

The RL Series Sliders are available in 2 sizes and with either 3 or 5 rollers.

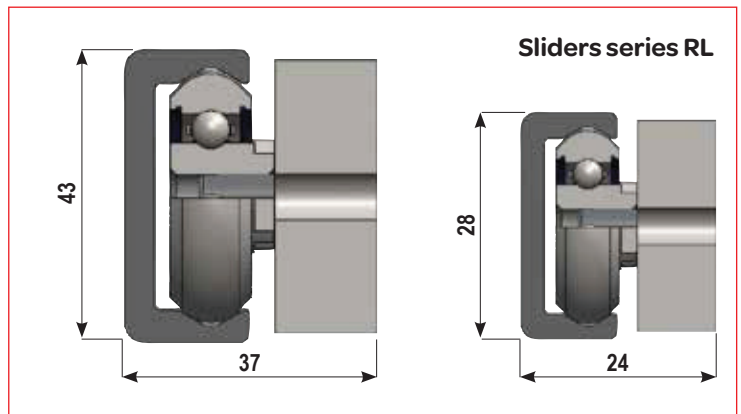

RLS Series Sliders

The RLS Series Sliders have a very slim body, as the most compact slider, without sacrificing performance. They also offer both threaded and through hole mounting options (RLS and RLS.C).

The standard slider body is made from zinc plated steel but is also available in complete inox. The RLS Series Sliders are available in 2 sizes, 2 materials, and with either 3, 4 or 5 rollers.

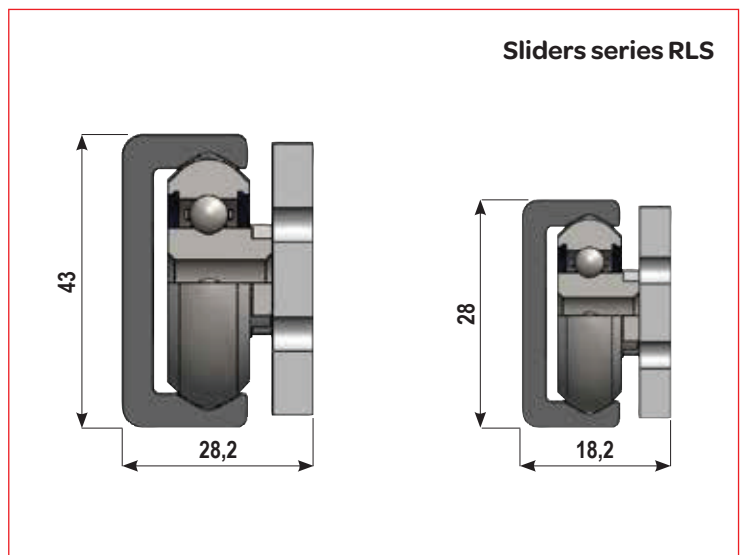

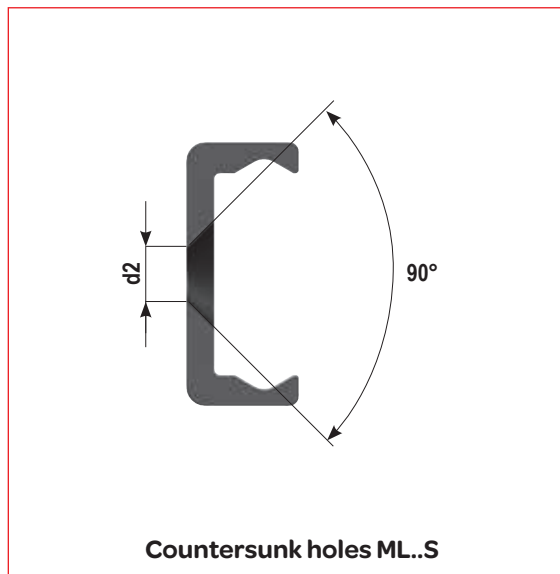
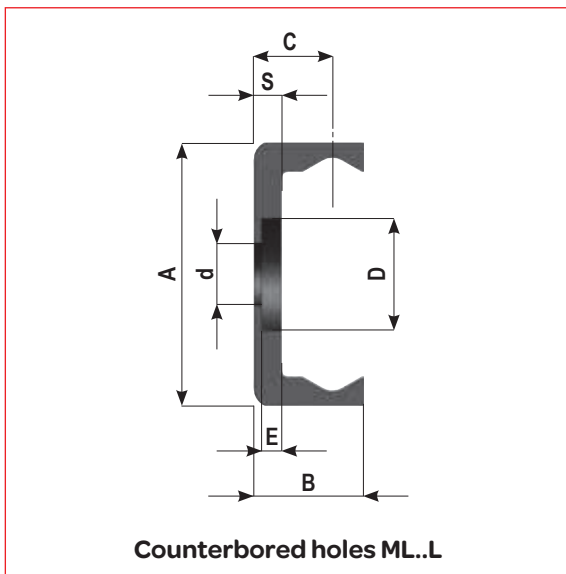
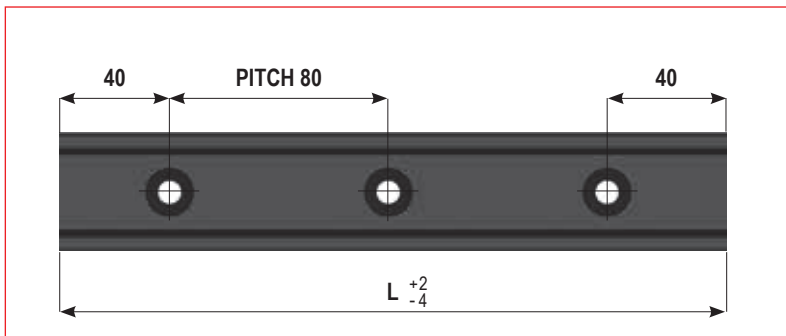

Lenght L (mm)	
ML28	ML43
240	
320	
400	400
480	480
560	560
640	640
720	720
800	800
880	880
960	960
1040	1040
1120	1120
1200	1200
1280	1280
1360	1360
1440	1440
1520	1520
1600	1600
1680	1680
1760	1760
1840	1840
1920	1920
2000	2000
2080	2080
2160	2160
2240	2240
2320	2320
2400	2400
2480	2480
2560	2560
2640	2640
2720	2720
2800	2800
2880	2880
2960	2960
3040	3040
3120	3120
3200	3200
3280	3280
3360	3360
3440	3440
3520	3520
3600	3600
3680	3680
3760	3760
3840	3840
3920	3920
4000	4000

(Code example: ML28L - 640)

Code	A (mm)	B (mm)	C (mm)	S (mm)	D (mm)	d (mm)	E (mm)	d2 (mm)	Screw type	Weight (kg/m)
ML28S	28	11,5	8,2	3				5,5	M5 DIN7991	1
ML28L					11	6	2	M5 TORX*		
ML43S	43	18,3	12,65	4,5				8,5	M8 DIN7991	2,3
ML43L					18	10	3,2	M8 TORX*		

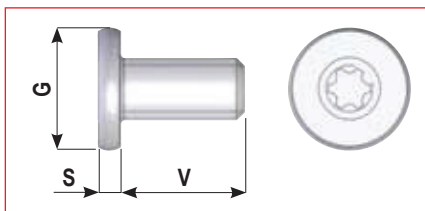

Screw type		G (mm)	S (mm)	V (mm)		Tightening Torque
M5 TORX	M5	10	2	10	T25	10Nm
M8 TORX	M8	16	3	16	T40	20Nm

TECHNICAL DATA

ML Series Rails are made in two sizes 28mm and 43mm with two types of mounting holes: ML .. L with counterbored mounting holes for special low head TORX mounting screws that are provided with the rail. ML .. S with countersunk mounting holes for UNI-standard ISO5933 fasteners. The rail has a "C" shaped cross-section with interior, concave raceways. The concave raceways are polished for smooth, low noise motion. The interior raceways are protected from accidental bumps

and other damage that can spoil the surface. The shape also protects the rollers from similar types of damage. ML Series Rails are made from carbon steel, that is hardened through high depth nitriding. The rails are then treated with the innovative TRACE-NOX process which delivers excellent corrosion resistance. This treatment is not a plating which can flake off, but instead penetrates and alters the material surface. The result is a very hard and durable, corrosion resistant linear rail that is black in color, due to the microimpregnation of oil and antioxidants.

The sliders of series RL offer a strong body with 4 fixing holes.

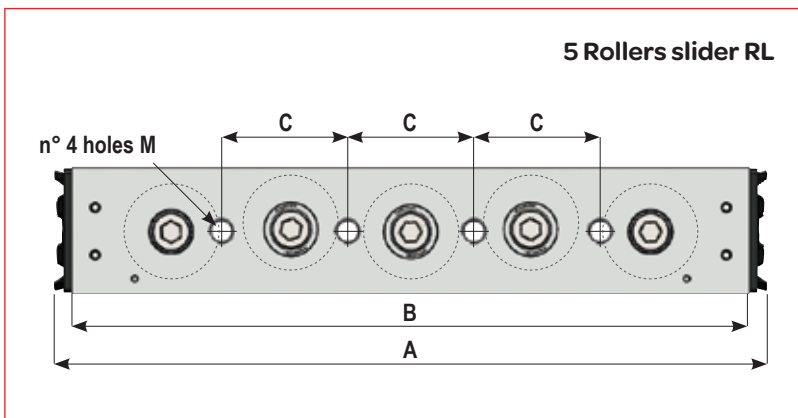
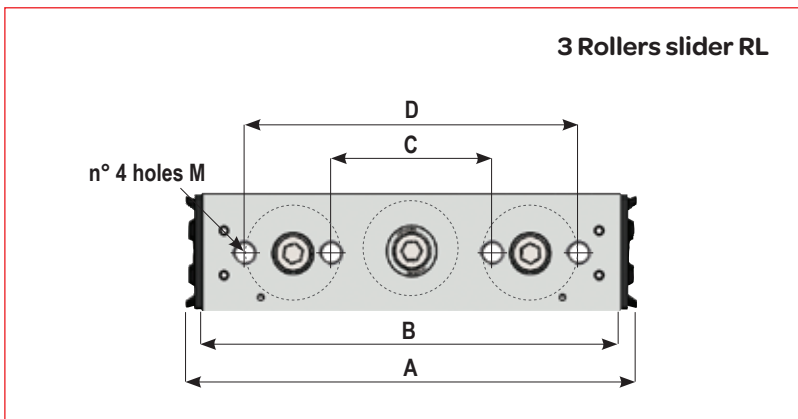
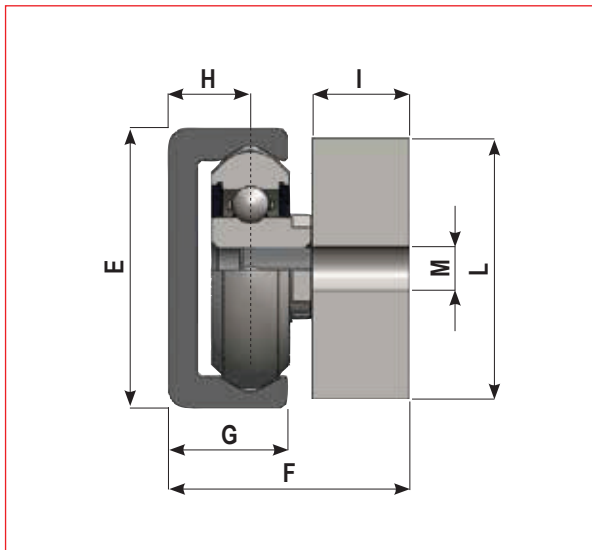

Code	Rail type	E (mm)	F (mm)	G (mm)	H (mm)	I (mm)	L (mm)	M (mm)	A (mm)	B (mm)	C (mm)	D (mm)	Weight (g)	Dynamic coeff. C (N)	Load capacity				
															Co rad (N)	Co ax (N)	Mx (Nm)	My (Nm)	Mz (Nm)
RL28-3	ML28	28	24	11,5	8,2	10	25	M5	105	97	35	78	220	4800	2000	750	5	13	27
RL28-5									151	143	25		330	6480	2700	1250	10	25	75
RL43-3	ML43	43	37	18,3	12,65	15	40	M8	152	143	55	114	700	11600	5000	1875	21	54	107
RL43-5									226	215	40		1070	15660	6750	3125	41	95	285

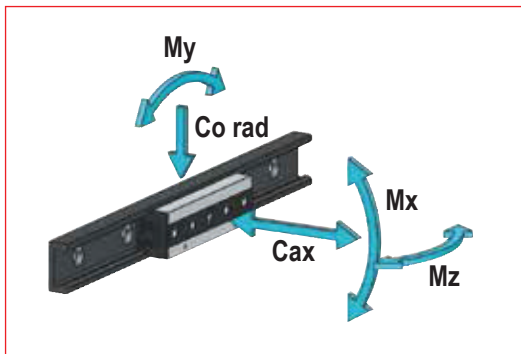

Guiding slider series RLS.

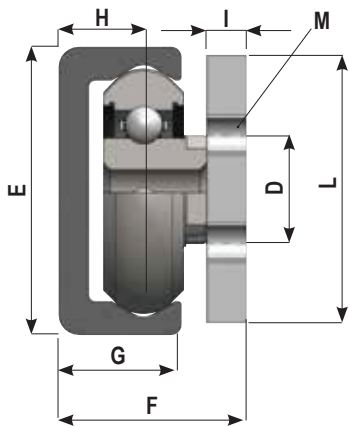

Version RLS-.. standard with threaded holes

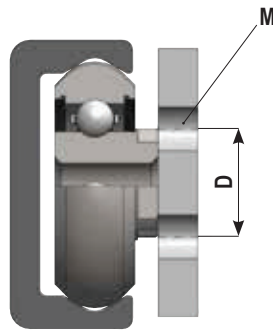

Version RLS-..C version with cylindrical holes

Very compact slider, with thin strong slider body, for application with limited space. Performance like standard RL-sliders. Featuring extra long 4-roller version to optimize performance with only 1 slider, instead of 2 sliders.

The sliders are available in standard version with threaded fixing holes RLS-.. and in version ...C with through passing holes for inside fixing with standard cylindrical screws DIN912, with no interference with the rollers.

Slider type	M	Type of fixing screws
RLS28-..	M5	
RLS28-..C	Ø 5,5	M5 DIN912
RLS43-..	M6	
RLS43-..C	Ø 6,5	M6 DIN912

3 Rollers slider RLS.

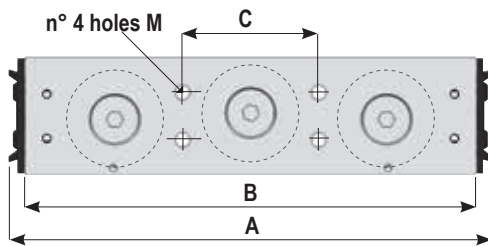

5 Rollers slider RLS.

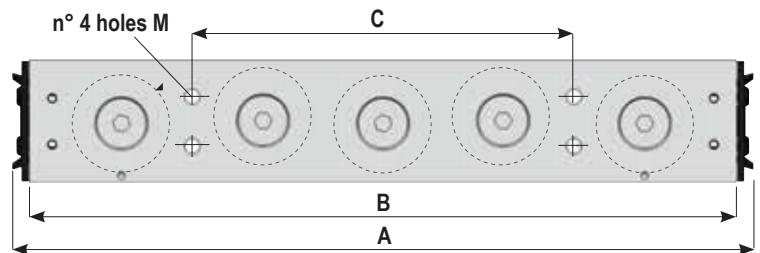

Long slider with 4 rollers RLS series

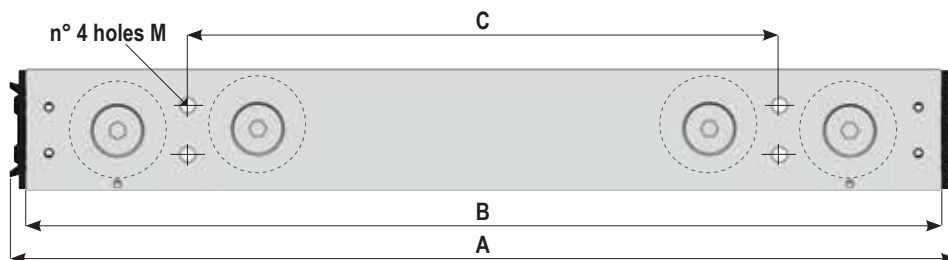

Code	Rail type	E (mm)	F (mm)	G (mm)	H (mm)	I (mm)	L (mm)	A (mm)	B (mm)	C (mm)	D (mm)	Weight (g)	Dynamic coeff. C (N)	Load capacity				
														Co rad (N)	Co ax (N)	Mx (Nm)	My (Nm)	Mz (Nm)
RLS28-3	ML28	28	18,2	11,5	8,2	4	25	114	106	32	10	140	4800	2000	750	5	16	32
RLS28-5								164	156	82	10	210	6480	2700	1250	10	28	82
RLS28-4L								208	200	126	10	230	4800	2000	1000	10	39	126
RLS43-3	ML43	43	28,2	18,3	12,65	6	40	164	153	46	16	440	11600	5000	1875	19	57	115
RLS43-5								241	230	124	16	670	15660	6750	3125	37	106	310
RLS43-4L								311	300	194	16	750	11600	5000	2500	37	150	485